



INSTALLATION OPERATION & SERVICE MANUAL

CONTROL PANEL WITH TIME SWITCH FOR INDOOR/OUTDOOR USE

Suitable for Pool Equipment Control and for Direct Connection of Underwater Lights

ELECTRICAL RATINGS: See inside Enclosure Door

DANGER

Risk of drowning!

*Do not permit unsupervised children to use pool or spa.
Close supervision of children required at all times.*

WARNING

Risk of electric shock!

*Test ground fault protection regularly. If it fails, do not use Pool or Spa. Contact qualified service professional for help.
Do not use this control as a power disconnect, it could turn ON unexpectedly.
Disconnect electricity at the main Panel before servicing this control or the equipment(s) connected to it.*

GENERAL INFORMATION

Many of today's energy efficient pools and spas utilize the advantages of a single electrical panel, containing all the necessary controls for the safe, efficient and automatic operation of the pool/spa equipment. In addition, this Panel can also be used to control any outdoor equipment, sign or pump within its rated capacity.

The Transformers supplied in these panels are specifically designed to supply 12 volts to underwater pool/spa lights. A grounded shield between the primary and secondary winding assures safe operation and the built-in circuit protection will disconnect power to the transformer in case of overload. These transformers are suitable for direct connection to underwater Pool and Spa lights.

The all-weather enclosure may contain a heavy-duty, industrial grade Time Switch, with mounting provision for a second Intermatic switching device. Also, it has provisions to install a switch inside as well as a switch or GFCI receptacle on the outside. The Time Switch can also accommodate an optional heater control (fireman) switch.

The Control is designed to operate any pump, within its rated capacity. However, if protection to prevent dry start is required by the pump manufacturer, it must be provided in addition to this Control. Contact pump manufacturer if not sure and/or for more details.

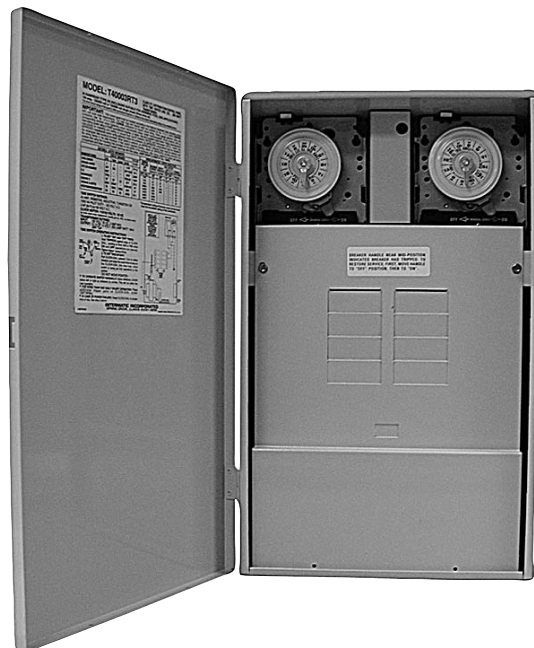

Transformer Rating	Input 60 Hz.	Secondary Output	
		Lamp Watts*	Volts
100W	120V. 1 Amp Max.	100 Max.	12 or 13
300W	120V. 3 Amp Max.	300 Max.	12, 13 or 14

* Any combination of bulbs, any tap.

CAUTION

Risk of injury or property damage!

Do not install or operate this equipment and other associated equipment without basic safety precautions.

Read and follow the safety instructions listed below and other basic safety precautions before installation or operation of this control and other associated equipment.

1. ***This control must be installed by a qualified person, according to the national and local electrical codes.***
2. ***Install this control not less than 5 feet (3 meters in Canada) from inside edge of pool and 1 foot (30cm) above ground.***
3. ***USE COPPER CONDUCTORS ONLY rated 75°C minimum.***
4. ***Do not exceed maximum ratings of individual components, wiring devices and current carrying capacity of conductors.***
5. ***For control grounding, bonding, installing and the wiring of underwater lights, refer to Article 680 of the National Electrical Code or Article 68 of the Canadian Electrical Code.***
6. ***The control should not operate any equipment which would cause bodily injury or property damage should it be activated unexpectedly.***

INSTALLATION

1. Remove the four #10 hex head screws from the back of the enclosure and attach mounting brackets to enclosure.
2. Select the proper location for the Control Panel and hang enclosure on a flat vertical surface or other support, using hardware suitable for the purpose.
3. Prepare the necessary conduit runs, terminate them at both ends and pull in the conductors as specified by the installation layout.
4. Refer to Figure 1 below; note that this enclosure contains one Time Switch. To wire the panel, follow the wiring diagram located inside the enclosure door. Make sure that connections to time switch terminals are tight (25 lb.-in. minimum) and insulation clears the pressure plate - see illustration.
5. If required by the heater manufacturer, install fireman switch kit 156T4042A (not furnished) on Time Switch Plate and make the fireman switch connections. Use at least #18 AWG wiring with insulation rated 300 Volt or higher. Place heater ON/OFF switch on heater to ON (see Figure 2 on page 3). Some heaters may require a special connecting harness, contact heater manufacturer for details.
6. To install an additional wiring device inside the enclosure, first remove rectangular knock-out(s) in dead front. Next, remove hex head screws in back of enclosure and install stand-offs* in place of screws. Attach wiring device to stand-offs.

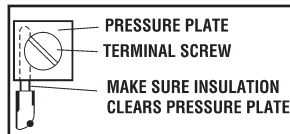

*Stand-offs are not furnished. Order 21T156A for a set of four (4) stand-offs and mounting hardware.

7. If external bonding is required, install a bonding lug at bottom of enclosure and bond installation according to code requirements.
8. Testing of the installation is optional and recommended only if pump is securely in place and will not be damaged by this test:
 - a. Turn the manual lever of the Time Switch to OFF.
 - b. Turn ON power at breaker panel.
 - c. Move the manual lever of Time Switch to the right (ON). Pump should start and run on full speed. In case of unsatisfactory results, turn OFF power, check your wiring, refer to Troubleshooting on Page 3.

9. The enclosure must be grounded as required by NEC, Article 680 and any applicable local codes. For Canadian installations, the transformer supply circuit must be protected by a ground fault circuit interrupter.
10. If this enclosure is used for direct connection of underwater lights, refer to 1999 NEC 680-21(b), 2002 NEC 680-24(b) or CEC 68-060, 062 and 066 for further details.
11. Make sure that all unused transformer taps (leads) are separately insulated.
12. Use the tables at the top of page 3 as a guide to determine the correct wire size.
13. Check voltage at lamp terminals after installation. It should be 12 ± 0.3 volts.
14. Install front panel over wiring compartment. The control is now ready for programming, see OPERATION section on Page 3.

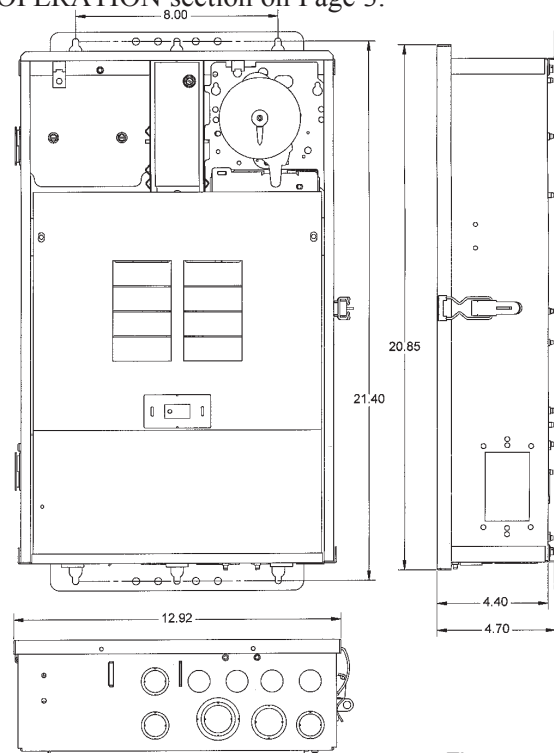

Figure 1

GUIDELINES FOR WIRE SIZE PER LENGTH

120 Volt Primary Input - 100 Watt Output

Distance* Feet	2#6AWG	2#8AWG	2#10AWG	2#12AWG	2#14AWG
5 Ft.	12V	12V	12V	12V	12V
30 Ft.	12V	12V	12V	13V	13V
60 Ft.	12V	12V	13V	13V	
90 Ft.	12V	13V	13V		
120 Ft.	13V	13V			
150 Ft.	13V	13V			
180 Ft.	13V				
210 Ft.	13V				
240 Ft.	13V				

* Length of run to light from transformer.

120 Volt Primary Input - 300 Watt Output

Distance* Feet	2#6AWG	2#8AWG	2#10AWG	2#12AWG
5 Ft.	12V	12V	12V	12V
10 Ft.	12V	12V	12V	13V
20 Ft.	12V	12V	13V	13V
30 Ft.	12V	13V	13V	14V
40 Ft.	13V	13V	14V	
50 Ft.	13V	13V	14V	
60 Ft.	13V	14V		
70 Ft.	13V	14V		
80 Ft.	13V	14V		
90 Ft.	14V			
100 Ft.	14V			
110 Ft.	14V			

* Length of run to light from transformer.

OPERATION

TO SET FILTER PUMP TIME SWITCH, follow instructions on the right. The length of the daily filtration/heating cycle depends on many variables such as size, shape, geographic location of the pool, water chemistry, type of pool equipment, usage and season of year. If not sure, contact your local pool service professional for advice.

THE FIREMAN SWITCH (Heater Protection Mechanism), if required, is factory set and shuts OFF the heater 20 minutes before the Time Switch turns OFF the filter pump. The Fireman Switch requires no setting or service.

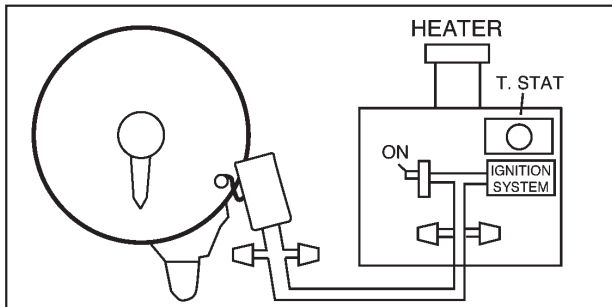

WARNING: Do not disconnect high limit or pressure switches.

Figure 2

TIME SWITCH OPERATING INSTRUCTIONS

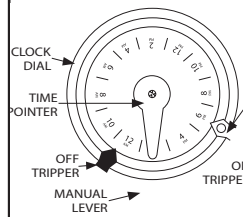

1. TO SET "ON" AND "OFF" TIMES: Hold TRIPPERS against edge of CLOCK-DIAL, pointing to time (AM or PM) when ON and OFF operations are desired. Tighten tripper screws firmly.

2. TO SET TIME-OF-DAY: Pull CLOCK-DIAL outward. Turn in either direction and align the exact time-of-day on the CLOCK-DIAL (the time now, when switch is being put into operation) to the pointer.

- TO OPERATE SWITCH MANUALLY: Move MANUAL LEVER below CLOCK-DIAL left or right as indicated by arrows. This will not affect the next operation.
- FOR MORE THAN ONE DAILY ON-OFF OPERATION: Place additional tripper pairs on CLOCK-DIAL (order 156T1978A).
- IN CASE OF POWER FAILURE: Reset CLOCK-DIAL to proper time of day. See step 2 above.

TROUBLESHOOTING

SYMPTOM	CAUSE(S)	CORRECTIVE ACTION
1. Time Switch will not keep time but dial is turning.	1a. Frequent power outages 1b. Wrong voltage/cycle 1c. Loose clock motor connections	Reset dial Change clock motor Check connections
2. Time Switch Dial stops at ON or OFF tripper.	2a. Loose tripper 2b. Bent dial 2c. Defective motor	Check/change tripper Check/change mechanism Change clock motor
3. Dial stops after switch turns OFF.	3a. LINE leads are connected to LOAD terminals	Reverse LINE and LOAD connections
4. Load is ON at all times - dial is turning.	4a. Welded contacts 4b. Two ON trippers and no OFF tripper on dial 4c. Defective mechanism	Change mechanism Change tripper Change mechanism
5. Dead clock motor. (Clock motor gears do not rotate).	5a. Defective clock motor (open coil due to lightning or surge) 5b. Loose clock motor connections 5c. Wrong voltage	Change clock motor Check connections Change clock motor

WIRING DIAGRAM

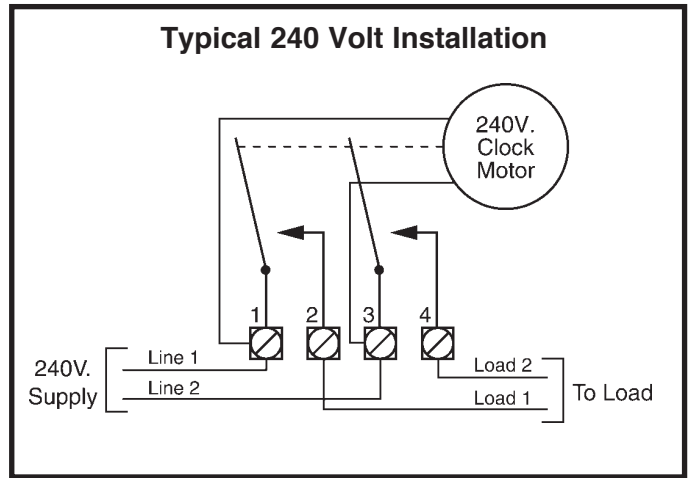
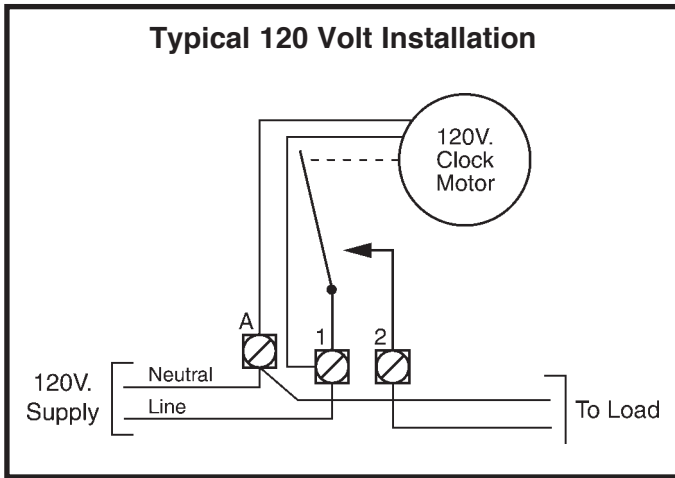

Filter and Cleaner Timer Inter-Connections

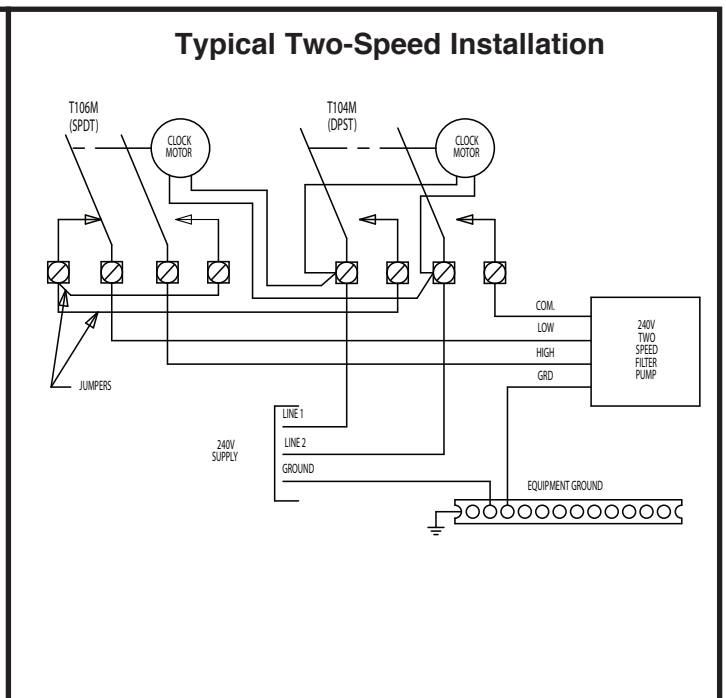
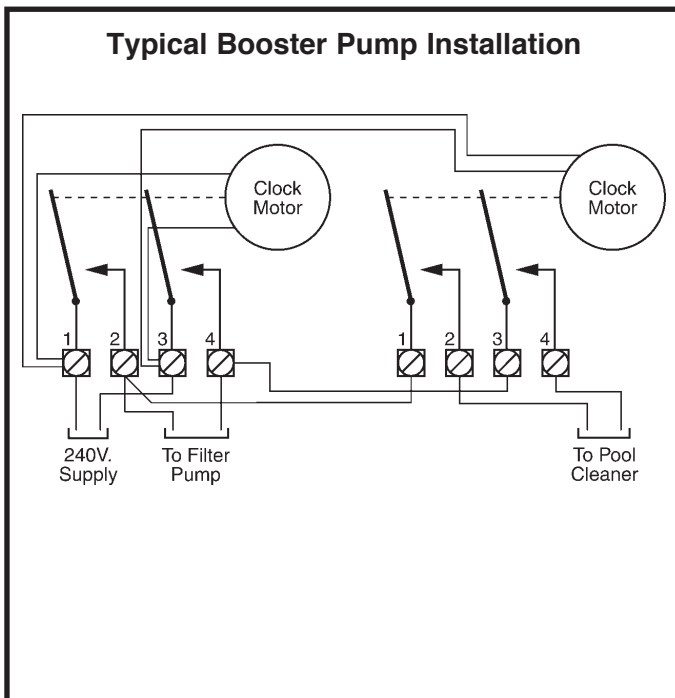

- NOTES:**
1. Grounding connections are not shown but must be provided. Refer to the National Electrical Code for details.
 2. Diagrams above are only two of the many variations this Panel can accommodate.

LIMITED ONE YEAR WARRANTY

If within the warranty period specified, this product fails due to a defect in material or workmanship, Intermatic Incorporated will repair or replace it, at its sole option, free of charge. This warranty is extended to the original household purchaser only and is not transferable. This warranty does not apply to: (a) damage to units caused by accident, dropping or abuse in handling, acts of God or any negligent use; (b) units which have been subject to unauthorized repair, opened, taken apart or otherwise modified; (c) units not used in accordance with instructions; (d) damages exceeding the cost of the product; (e) sealed lamps and/or lamp bulbs, LED's and batteries; (f) the finish on any portion of the product, such as surface and/or weathering, as this is considered normal wear and tear; (g) transit damage, initial installation costs, removal costs, or reinstallation costs.

INTERMATIC INCORPORATED WILL NOT BE LIABLE FOR INCIDENTAL OR CONSEQUENTIAL DAMAGES. SOME STATES DO NOT ALLOW THE EXCLUSION OR LIMITATION OF INCIDENTAL OR CONSEQUENTIAL DAMAGES, SO THE ABOVE LIMITATION OR EXCLUSION MAY NOT APPLY TO YOU. THIS WARRANTY IS IN LIEU OF ALL OTHER EXPRESS OR IMPLIED WARRANTIES. ALL IMPLIED WARRANTIES, INCLUDING THE WARRANTY OF MERCHANTABILITY AND THE WARRANTY OF FITNESS FOR A PARTICULAR PURPOSE, ARE HEREBY MODIFIED TO EXIST ONLY AS CONTAINED IN THIS LIMITED WARRANTY, AND SHALL BE OF THE SAME DURATION AS THE WARRANTY PERIOD STATED ABOVE. SOME STATES DO NOT ALLOW LIMITATIONS ON THE DURATION OF AN IMPLIED WARRANTY, SO THE ABOVE LIMITATION MAY NOT APPLY TO YOU.

This warranty service is available by either (a) returning the product to the dealer from whom the unit was purchased or (b) completing a warranty claim online at www.intermatic.com. This warranty is made by: Intermatic Incorporated, Customer Service 7777 Winn Rd., Spring Grove, Illinois 60081-9698. For warranty service go to: <http://www.intermatic.com> or call 815-675-7000.

Because of our commitment to continuing research and improvements, Intermatic Incorporated reserves the right to make changes, without notice, in the specifications and material contained herein and shall not be responsible for any damages, direct or consequential, caused by reliance on the material presented.

INTERMATIC INCORPORATED, SPRING GROVE, IL 60081-9698

<http://www.intermatic.com>