

<http://waterheatertimer.org/Paragon-timers-and-manuals.html>

EC72, EC72D
GENERAL INSTRUCTIONS



MAPLE CHASE COMPANY PRODUCT WARRANTY

The products manufactured by Maple Chase Company and used in commercial, industrial or institutional applications are warranted to be free from defects in workmanship or material under normal use and service for a period of one (1) year from the date of purchase by the end user (whether separately or as a component of other products), or eighteen (18) months from the date of manufacture of the Maple Chase Company products, whichever is less.

Maple Chase's obligation under this warranty is limited to replacing or repairing, free of charge, any product returned to Maple Chase with transportation charges prepaid, providing that Maple Chase's examination discloses to its satisfaction that such product is defective.

This warranty does not apply to damage caused by misuse, neglect, accident or mishandling, or to products which have been subject to repair by anyone other than Maple Chase Company, opened or taken apart, or which have not been properly installed or have been used other than in accordance with Maple Chase's instructions.

THIS WARRANTY IS IN LIEU OF ANY OTHER WARRANTY, EITHER EXPRESS OR IMPLIED, INCLUDING BUT NOT LIMITED TO ANY IMPLIED WARRANTY OR MERCHANTABILITY OR FITNESS FOR ANY PARTICULAR PURPOSE.

IN NO EVENT SHALL MAPLE CHASE COMPANY BE LIABLE TO PURCHASER OR ANY THIRD PARTY FOR ANY LOSS OF PROFITS OR OTHER INCIDENTAL, CONSEQUENTIAL OR SPECIAL DAMAGES WHATSOEVER.

PRODUCT IMPROVEMENTS

Maple Chase Company reserves the right under its product improvement policy to change construction or design without obligation regarding previous models, and furnish equipment when so altered without reference to illustrations or specifications used herein.

CONTENTS

INTRODUCTION	5
PROGRAMMING CAPABILITIES	6
SPECIFICATIONS	7
EC72 INSTALLATION, BATTERY and WIRING	11
EC72D INSTALLATION, BATTERY and WIRING	14
FRONT PANEL DESCRIPTION	19
GENERAL PROGRAMMING INSTRUCTIONS	20
MOMENTARY OPTION	22
PROGRAMMING TIME, DAY, and DATE	24
PROGRAMMING EVENTS	26
OVERRIDE	29
PROGRAMMING HOLIDAYS	30
MAINTENANCE	33
APPLICATIONS	34
TROUBLESHOOTING	45
GLOSSARY	46
INDEX	47

EC72, EC72D

Electronic Time Controls

DESCRIPTION

The EC72 and EC72D are seven-day, two-channel time controls that will switch two different electrical circuits according to a pre-set, time-of-day program, thus providing precise control of those circuits from a central location and common time base. Once programmed, the controls will automatically turn loads ON and OFF according to your schedule, compensating for changes in Daylight Savings Time, adjusting for Leap Year and altering ON/OFF events on designated holidays.

APPLICATIONS

The EC72 Series provides ideal control for indoor and outdoor lighting, heating, ventilation and air conditioning, and motors, pumps and fans in convenience and retail stores, commercial buildings, industrial facilities, schools and churches. The Momentary Option, accessed by clipping a jumper wire, provides a two-second momentary contact closure ideal for ringing school bells and church chimes or operating latching relays. The 12-volt DC model is ideal for battery-powered applications such as security systems, remote deer feeders and air sampling machines.

Both Models possess identical programming capabilities. The differences between the controls lie in housing - the EC72 is enclosed in a NEMA 1 indoor metal case, while the EC72D is a DIN model, housed in an indoor plastic case.

The EC72D typically is used in indoor or outdoor panels. The EC72 is used for indoor stand-alone applications.

PROGRAMMING CAPABILITIES

- **True 7-Day Programming** - each day of the week can be uniquely programmed.
- **16 Events per Channel** - up to 16 ON/OFF events can be programmed for each channel.
- **Repeat Programming** - simplifies programming and increases the total number of events through daily repetition of certain ONs and OFFs; creates a maximum of 112 events per week per channel.
- **Holiday Programming** - twelve single-day holidays and two holiday durations are programmable by date.
- **Daylight Saving Time** - can be programmed for automatic changeover in the spring and fall.
- **Automatic Leap Year Correction**
- **Momentary Option** - any EC72 Series model can be converted to a momentary output control by clipping a jumper wire; all events become ON events of two-second duration. (See page 22.)
- **Manual Override** - temporarily reverses current output state; begins immediately when initiated and remains in effect until overridden again or until the next programmed event; each channel can be overridden independently.

SPECIFICATIONS

ELECTRICAL

Power Requirements

MODEL	VOLTAGE	HERTZ	VA REQ.
EC72/24	24 Vac (+ 10 - 15%)	50/60	4
EC72/120	100-120 Vac	50/60	4
EC72/240	200-240 Vac	50/60	4
EC72/277	277 Vac	50/60	4
EC72D/12	12 Vdc	—	—
EC72D/24	24 Vac (+ 10 - 15%)	50/60	4
EC72D/120	100-120 Vac	50/60	4
EC72D/240	200-240 Vac	50/60	4

Output - Two SPDT relays with contacts rated as follows:

VOLTAGE	RESISTIVE	INDUCTIVE	H.P.	PILOT DUTY
12 Vdc	.1A-15 a	—	—	—
24 Vac	15 A	15 A	1/10	60 VA
120 Vac	15 A	15 A	1/3	345 VA
240 Vac	10 A	8 A	1/2	450 VA
277 Vac	10 A	8 A	—	450 VA

Wiring - Terminals can accommodate 14 to 24 AWG wire.

ACCURACY

Time-of-day - Maintained time is as accurate as line frequency.

Resolution - One minute for time-of-day and programmed ON/OFF events.

SPECIFICATIONS continued

POWER OUTAGE CARRYOVER

Program and Time-of-Day Backup - 100 hours of carryover with a 9-volt alkaline battery. 275 hours of carryover with a 9-volt lithium battery (Ultralife, U9VL.) Battery not provided. During a power outage, the time and program are maintained, but the output relays remain de-energized.

ENVIRONMENTAL

The EC72 Series should be mounted indoors in an environment that is free from excessive contaminants such as oil, moisture and dirt or in an appropriate outdoor panel. For outdoor use, an EC72D can be mounted in a NEMA 3 enclosure 4010EC (X9092) which must be purchased separately.

PHYSICAL

Mounting

EC72D — Surface or DIN-rail (35mm, DIN-EN50022) with plug-in base

EC72 — NEMA 1 case mounting

Weight — EC72D — Approximately 1 lb 3 oz (0.54 kg)
EC72 — Approximately 2 lb (0.90 kg)

Dimensions - EC72D — Width 10.5 cm (4 1/8")
Height 10.5 cm (4 1/8")
Depth 7.6 cm (3")

* EC72 — Width 10.8 cm (4 1/4")
Height 20.0 cm (7 7/8")
Depth 7.6 cm (3")

* outside dimensions, including hinge and bracket

EC72D

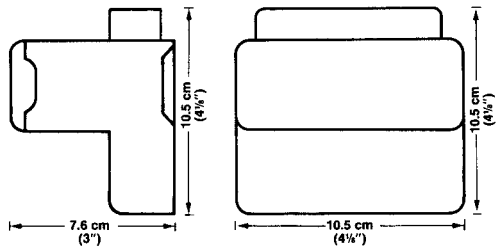

EC72

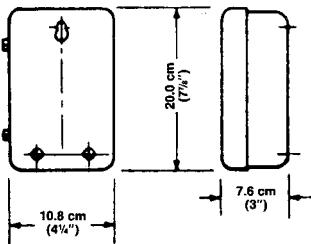

Figure 1. EC72 Series Dimensions

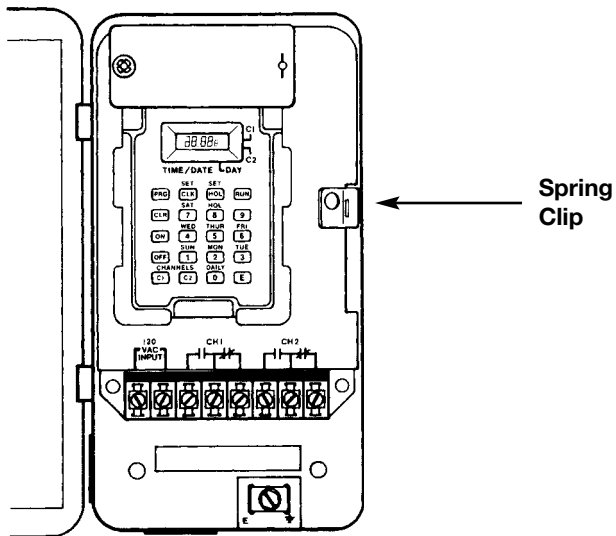

Figure 2. EC72 Installation

INSTALLATION - EC72

NEMA 1 Case Mounting

1. Press back on spring clip at right center of metal case. See Figure 2 at left. Lift control out and set aside.
2. Remove desired knockouts to provide wiring access.
3. Mount case in a vertical position using the mounting holes provided.
4. Replace control by inserting tabs on left side of front panel into slots on left side of case. Push down and snap into place.
5. Connect an electrical ground to grounding terminal screw located inside the metal case bottom. See Figure 2 at left.

BATTERY - EC72

Installation — Purchase a 9-volt alkaline or lithium battery (Ultralife, U9VL).

Remove battery cover by pulling up right side of cover from the extrusion that holds it. Swivel battery cover up and out of the way. Snap battery into battery clip. Mark date on battery log. Replace battery cover.

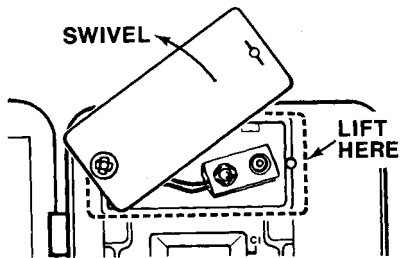

Figure 3. EC72 Battery Cover Removal

Replacement —

Alkaline, approximately every 2 years.

Ultralife U9VL, approximately every 5 years.

A battery log is provided inside the battery cover to record battery replacement dates.

WIRING — EC72

1. Remove the gray fish paper insulator card in order to provide access to the terminal block. Wiring access for power input and relay output is provided at bottom of terminal block. Terminals can accommodate 12 to 24 AWG wire.
2. Wire 12 Vdc, 24, 120, 240 or 277 Vac to terminals 1 and 2. See Figure 4 below. Determine voltage according to the model selected.

CAUTION: Damage will occur to unit if incorrect voltage is applied. Application of incorrect input voltage will void warranty. See product label to make sure you are applying the correct voltage.

3. Connect output wiring as required for the particular application. See wiring diagrams on pages 34-44.
4. Make sure that all wiring is in accordance with national and local electrical codes.

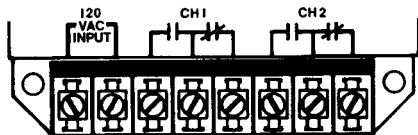

Figure 4. EC72 Terminals

INSTALLATION — EC72D

EC72D Surface Mounting

1. Remove back mounting plate by releasing the bright red spring-loaded catch. See Figure 5 below.
2. Install back mounting plate on a vertical or horizontal surface, flush side to panel or wall. Utilize the mounting holes on the back mounting plate. (Screws are not provided.)
3. Pull down on spring-loaded catch and snap control onto back mounting plate.

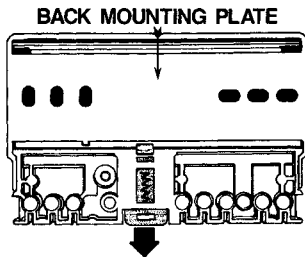

Figure 5. EC72D Back

EC72D and EC72E DIN Rail Mounting

1. Remove back mounting plate by releasing spring-loaded catch. See Figure 5 above. Store or discard mounting plate.
2. Snap base connection block onto DIN-rail.

BATTERY — EC72D

Installation - Purchase a 9-volt alkaline or lithium battery (Ultralife, U9VL).

Remove battery cover by pressing sides together and pulling left or right. See Figure 6 below.

Snap battery into battery clip. Mark date on battery log. Replace battery cover.

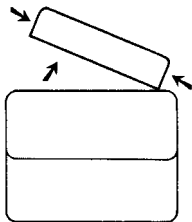

Figure 6. EC72D Battery Cover Removal

Replacement — Alkaline, approximately every 2 years.

Ultralife U9VL, approximately every 5 years.

A battery log is provided inside the battery cover to record battery replacement dates.

WIRING - EC72D

1. Loosen terminal cover screw (see Figure 7) and set terminal cover aside. The screw is captive to the control. Wiring access for power input and relay output is provided at bottom of terminal block. Terminals can accommodate 12 to 24 AWG wire.
2. Wire 12 Vdc or 24, 120 or 240 Vac to terminals 1 and 2. See Figure 7 at right. Determine voltage according to the model selected.

CAUTION: Damage will occur to unit if incorrect voltage is applied. Application of incorrect input voltage will void warranty. See product label to make sure you are applying the correct voltage.

3. Connect output wiring as required for the particular application. See pages 34-44 for wiring diagrams.
4. Cut out terminal cover for wiring. Cutting guides are molded in the inside bottom of the cover.
5. Replace terminal cover and tighten terminal screw.
6. Make sure that all wiring is in accordance with national and local electrical codes.

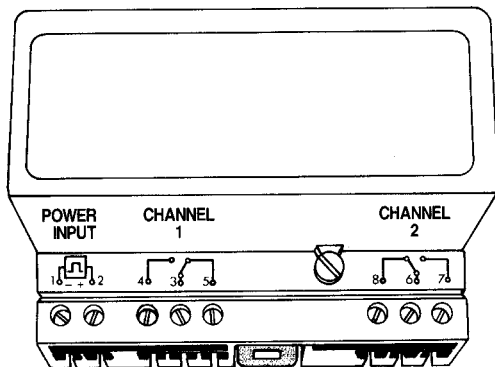

Figure 7. EC72D Terminals

1. Contacts are shown in the OFF, or de-energized, state.
2. Maple Chase Company's solid state controls utilize DRY CONTACTS. Input power enables the control to keep time, store programmed information and carry out instructions, but input power *does not power the loads*. In order to make the circuits functional, you must provide power to the contacts as shown in the wiring diagrams on pages 34-44.

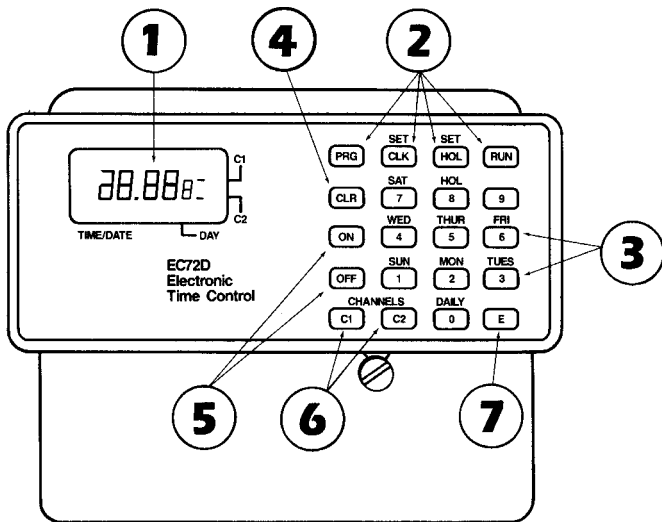

Figure 8. EC72 Series Keypad and Screen

FRONT PANEL DESCRIPTION

The keypad and screens on all EC72 Series controls are identical. On the EC72, however, the screen is located *above* the keypad, while on the EC72D, the screen is located to the *left* of the keypad.

- 1 Time/Date Indicator** — displays hours and minutes in 24-hour format (e.g., 00:00=midnight, 12:00=noon, 23:00=11:00 PM) or month and date for current day or an event being programmed or reviewed (101=January 1).
Day of Week Indicator — displays current day of week or day being programmed or reviewed (Sunday=1, Monday=2, Tuesday=3, Wednesday=4, Thursday=5, Friday=6, Saturday=7, Holiday=8, Daily=0).
Channel Indicators — bar(s) appear when channel(s) C1/C2 are energized.
- 2 Mode Keys — PRG, CLK, HOL, RUN** — used to select mode of operation.
- 3 Number/Day Keys** — used to program time, day, month, date and year.
- 4 Clear Key** — must be used to clear an old entry before a new one can be entered; also used to clear errors.
- 5 ON/OFF Keys** — used to select an ON or OFF event.
- 6 Channel Keys** — used to select Channel 1 or 2 (C1/C2) for programming or review; also used to initiate manual override.
- 7 Enter Key** — used to enter a new event or to review program.

BEFORE YOU BEGIN PROGRAMMING...

Make sure you understand the programming capabilities of your control:

7-Day Programming

Each day of the week can be uniquely programmed. In other words, the schedule of ON/OFF events can vary for each day of the week — e.g., 10:00 AM ON Monday, 8:00 AM ON Tuesday — Thursday, 7:00 AM ON Friday, 12:00 noon ON Saturday, etc. Whatever schedule is programmed will be repeated weekly, with the same ONs and OFFs every Monday, every Tuesday, etc.

16 Events per Channel

An event is a single change in operation; i.e., switching ON or switching OFF. Up to 16 ON/OFF events can be programmed for each channel — a maximum of 8 ONs and 8 OFFs for Channel 1 and 8 ONs and 8 OFFs for Channel 2.

If one ON and one OFF is assigned to each day of the week — *at different times each day* — then 14 events would be used (7 days x 2 events/day). The remaining ON and OFF for that channel could then be assigned to the Eighth Day — or Holiday Program — discussed on the next page.

If one or more ON/OFF event occurs *at the same time every day*, then that event is a Daily Event and uses *only one* of the 16 available events. See Repeat Programming on the next page.

Momentary Option

Any EC72 Series model can be converted to momentary output. This decision should be made prior to programming. See pages 22-23 for more information.

Repeat Programming

Repeat Programming simplifies programming and increases the total number of events through daily repetition of certain ONs and OFFs. For example, say that a certain event will occur at the same time every day — e.g., 8:00 AM ON. Rather than programming 8:00 AM ON Monday, 8:00 AM ON Tuesday, 8:00 AM ON Wednesday, etc., the Daily Key can be used, causing the event to be repeated each and every day of the week and using *only one* of the 16 available events. The remaining 15 events can be used to create additional daily ONs and OFFs or they can be used to create unique once-a-week events; e.g., 6:00 PM ON Wednesday *only*.

At least one ON and one OFF should be reserved for Holiday Programming. See below.

Repeat Programming creates a maximum capacity of 112 events per week per channel (16 events/channel x 7 days).

Holiday Programming

Twelve single-day holidays and two holiday durations are programmable by date. The Eighth Day, or Holiday, Program will repeat the *same* special schedule on *each* of the holidays assigned to it — whether that schedule includes one or more events or no events.

Holiday Programming includes two steps:

1. Telling the control *which days* should be included in the holiday schedule (see page 30); and
2. Programming the events that should occur on those holidays or informing the control that no events should occur. (See page 24.)

MOMENTARY EVENT OPTION

The Momentary Option provides a two-second momentary contact closure that is ideal for ringing school bells and church chimes or utilizing latching relays. Any EC72 Series model can be converted to momentary output by clipping a jumper wire, which causes all events to become ON events of two-second duration.

Three changes take place when the jumper is clipped:

1. Determining whether an event should be an ON or OFF event is unnecessary, since all events become ON events of two-second duration.
2. When Manual Override is used on either channel, the relay for that channel will be energized for two seconds.
3. Channel indicator bars are not displayed when relays energize.

See Applications at the back of this book for further information.

To convert EC72 to a momentary output control:

1. Disconnect all power to control.
2. Remove control from the metal case as described in Step 1 on page 11.
3. Clip the jumper wire, J1, located on the back side of the control unit in the upper left-hand corner of the green board. See Figure 9, if date code on circuit board is before Dec. 1987. If date code is after Dec. 1987, see Figure 9A.

FIGURE 9.
EC72 Jumper Wire



**Figure 9A.
EC72
Jumper Wire**

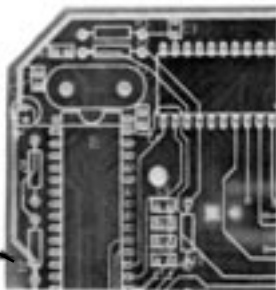

To convert the EC72D:

1. Remove the control according to directions on page 17.
2. The jumper wire, J29, is located on the back side of the control in the upper left-hand corner of the board. See Figure 10 below. Clip J29.



Figure 10. EC72D Jumper Wire

TO PROGRAM TIME, DAY AND DATE

- | Step | Key | Description |
|------|---------------|----------------------------------------------------------------------------------------------------------------------------------------------------------------------------------------------------------------------------------------------|
| 1. | | Install battery/power. 0:00 1 displayed; colon and 1 flashing. |
| 2. | CLK | Flashing stops. |
| 3. | #### # | Enter current time, then day of week.
Enter four digits for time (e.g., 0900=9:00 AM).
Use 24-hour clock format. See chart below.
For day of week, 1=Sunday, 2=Monday, 3=Tuesday,
4=Wednesday, 5=Thursday, 6=Friday, 7=Saturday. |
| 4. | E | Enters time. 101 displayed, indicating January 1. |
| 5. | #### | Enter current month, then date. Press two keys for month and two for date (e.g., 0101=January 1). |
| 6. | E | Enters month and date. 84 is displayed, indicating 1984. |
| 7. | ## | Enter current year. Two keys must be pressed (e.g., 88) |
| 8. | E | Enters year. Control switches automatically to run mode. Time and day-of-week displayed. Colon flashing. |
- | | | |
|---------------|----------------|----------------|
| 0:00=midnight | 08:00=8:00 AM | 16:00=4:00 PM |
| 01:00=1:00 AM | 09:00=9:00 AM | 17:00=5:00 PM |
| 02:00=2:00 AM | 10:00=10:00 AM | 18:00=6:00 PM |
| 03:00=3:00 AM | 11:00=11:00 AM | 19:00=7:00 PM |
| 04:00=4:00 AM | 12:00=noon | 20:00=8:00 PM |
| 05:00=5:00 AM | 13:00=1:00 PM | 21:00=9:00 PM |
| 06:00=6:00 AM | 14:00=2:00 PM | 22:00=10:00 PM |
| 07:00=7:00 AM | 15:00=3:00 PM | 23:00=11:00 PM |

In 24-hour format, minutes remain the same (e.g., 13:35 = 1:35 PM).

To Review Date

Step	Key	Description
1.	CLK	Current time displayed. Flashing stops.
2.	E	Current month and date displayed.
3.	E	Current year displayed.
4.	RUN	Restores normal operation. Time and day displayed. Colon flashing.
5.	C1/C2	Switching of loads occurs only in the RUN mode. If an event was scheduled to occur while you were reviewing information, the event will not have taken place if you were reviewing during the entire minute that the event was scheduled to occur. Press C1 or C2 to initiate override if the status of either circuit is incorrect. <i>This applies to programming as well as reviewing.</i>

To Change Time, Day or Date

Step	Key	Description
1.	CLK	Currently programmed time displayed. Flashing stops.
2.	#### #	Enter correct time, then day of week.
3.	E	Enters new time. Current programmed date displayed.
4.	####	Enter new month, then date if either is incorrect.
5.	RUN	Time and day displayed. Colon flashing.
6.	C1/C2	Press C1 or C2 to initiate override if the status of either circuit is incorrect. See above, Step 5, <i>To Review Date</i> .

TO PROGRAM ON/OFF EVENTS

- | Step | Key | Description |
|------|---------------|---------------------------------------------------------------------------------------------------------------------------------------------------------------------------------------------------------------------------------------------------------------------------------------------------------------------------------------------------------------------------------------------------------------------------------|
| 1 | PRG | Display goes blank except for the Channel indicator bars, which flash alternately to indicate that a channel number key must be pressed. |
| 2 | C1/C2 | Selects channel to be programmed. C1 or C2 Indicator bar energizes and E:01 (first event) is displayed. |
| 3 | #### # | Enter time, then day of week for first event. Enter four digits for time (e.g., 0900=9:00 AM). For day of week, 1=Sunday, 2=Monday, 3=Tuesday, 4=Wednesday, 5=Thursday, 6=Friday, 7=Saturday, 8=Holiday , 0=Daily .
<i>If no events are desired on a particular day — for instance, on Day 8 (the Holiday Program) — key in 0000 for the time and — in Step 4 below — select ON or OFF for the entire day.</i> |
| 4 | ON/OFF | Selects an ON or OFF event. Colon signifies an ON; no colon signifies an OFF.
<i>This step is unnecessary if you have used the Momentary Option, since all events become ON events.</i> |
| 5 | E | Enters programmed event into memory. Next event slot (E:02 - E:16) displayed. |
| 6 | | Repeat Steps 3 - 5 for all events on one channel. The control will automatically switch to E:01 on the other channel. Repeat Steps 3 - 5. |
| 7 | RUN | Restores normal operation. Time and day displayed. Colon flashing. |

Use the following chart to record events. Circle all days for Daily Events (Key 0).

EVENTS																			
C1	TYPE	TIME	DAY OF WEEK					C2	TYPE	TIME	DAY OF WEEK								
1	ON / OFF		S	M	T	W	T	F	S	1	ON / OFF		S	M	T	W	T	F	S
2	ON / OFF		S	M	T	W	T	F	S	2	ON / OFF		S	M	T	W	T	F	S
3	ON / OFF		S	M	T	W	T	F	S	3	ON / OFF		S	M	T	W	T	F	S
4	ON / OFF		S	M	T	W	T	F	S	4	ON / OFF		S	M	T	W	T	F	S
5	ON / OFF		S	M	T	W	T	F	S	5	ON / OFF		S	M	T	W	T	F	S
6	ON / OFF		S	M	T	W	T	F	S	6	ON / OFF		S	M	T	W	T	F	S
7	ON / OFF		S	M	T	W	T	F	S	7	ON / OFF		S	M	T	W	T	F	S
8	ON / OFF		S	M	T	W	T	F	S	8	ON / OFF		S	M	T	W	T	F	S
9	ON / OFF		S	M	T	W	T	F	S	9	ON / OFF		S	M	T	W	T	F	S
10	ON / OFF		S	M	T	W	T	F	S	10	ON / OFF		S	M	T	W	T	F	S
11	ON / OFF		S	M	T	W	T	F	S	11	ON / OFF		S	M	T	W	T	F	S
12	ON / OFF		S	M	T	W	T	F	S	12	ON / OFF		S	M	T	W	T	F	S
13	ON / OFF		S	M	T	W	T	F	S	13	ON / OFF		S	M	T	W	T	F	S
14	ON / OFF		S	M	T	W	T	F	S	14	ON / OFF		S	M	T	W	T	F	S
15	ON / OFF		Holiday (Key 8)					15	ON / OFF		Holiday (Key 8)								
16	ON / OFF		Holiday (Key 8)					16	ON / OFF		Holiday (Key 8)								

TO REVIEW OR CHANGE EVENTS

Step	Key	Description
1	PRG	Display goes blank except for Channel indicator bars, which flash alternately to indicate that a channel number key must be pressed.
2	C1/C2	Select channel to be reviewed. Selected Channel Indicator bar will energize. The first programmed event will be displayed. If the first event has not programmed event will be displayed.
3	E	Press repeatedly to review all 16 events for one channel, followed by all 16 events for the other channel.
4	CLR	Press if any displayed time and/or day must be changed.
5	#### #	Enter correct time and day.
6	RUN	Restores normal operation. Time and day displayed. Colon flashing.
7	C1/C2	Switching of loads occurs only in the RUN mode. If an event was scheduled to occur while you were reviewing or programming information, the event will not have taken place if you were reviewing or programming during the entire minute that the event was scheduled to occur. Press C1 or C2 to initiate override if the status of either circuit is incorrect.

NOTES ON EVENTS

The weekday keys 1 - 7 and the holiday key 8 have priority over the daily key 0. If an ON/OFF event is programmed for an individual weekday, then all programmed daily events are cancelled for that day on that channel. For example, if you program a daily On at 8:00 AM and a daily OFF at 5:00 PM, and then program an ON to occur only on Wednesday at 10:00 AM, the ON at 8:00 and OFF at 5:00 will be cancelled out; you will need to program a separate OFF for Wednesday.

You can program daily events and still skip a day by programming an event with 0000 for the time on that day. For instance, say that you want an 8:00 AM ON and 5:00 PM OFF for each weekday, but you wish to skip both Saturday and Sunday. Program the ON and OFF as daily events and then program a 0000 event for each Saturday and Sunday. See Step 3 on page 26. This process, however, cannot be used if the control has been converted to momentary output; if you have selected the Momentary Option, there is no way to use the daily function and also skip any day(s) — all daily events will occur every-day. In some applications, this can be overcome by external wiring. See page 42.

OVERRIDE

To initiate override, the control must be in the RUN mode. Press **C1** and/or **C2** to override desired channel from ON to OFF, or OFF to ON. Channel remains in that state until overridden again or until the next opposite programmed event. If control has been converted to momentary output, initiating override will energize the relay(s) for two seconds.

HOLIDAY and DAYLIGHT SAVINGS TIME

Twelve single holidays (H:01 - H:12) and two holiday durations (H:13 - H:16) are provided. Fill in the chart at right before you begin.

Step	Key	Description
1	HOL	H:01 displayed, indicating Holiday 1.
2	####	Enter month, then date of holiday. Press two keys for month and two for date.
3	E	Enters holiday into memory and advances to next holiday. Repeat steps 2 and 3 until all single holidays through H:12 are programmed.
4	E	H:13 displayed, indicating begin date for first holiday duration.
5	####	Enter month, then date that holiday duration will begin.
6	E	H:14 displayed, indicating end date for first holiday duration.
7	####	Enter month, then date that holiday duration will end.
8		Repeat steps 4 - 7 for second holiday duration. H:15 denotes begin date; H:16 denotes end date.
9	E	Displays SPr, indicating start date for Spring Daylight Savings Time changeover.
10	####	Enter month, then date of spring changeover.
11		Repeat steps 9 and 10 to program Fall Daylight Savings Time changeover. Control displays FaLL.
12	RUN	Restores normal operation. Time and day displayed. Colon flashing.

Refer to page 26 for ON/OFF events for HOLIDAYS.

Use the following chart to record days that will follow the holiday schedule:

HOLIDAYS			
NO.	DATE	DESCRIPTION	
H:01			
H:02			
H:03			
H:04			
H:05			
H:06			
H:07			
H:08			
H:09			
H:10			
H:11			
H:12			
H:13	Duration 1 begins	H:14	Duration 1 ends
H:15	Duration 2 begins	H:16	Duration 2 ends
SPR		FALL	

To Review or Change Holidays

Step	Key	Description
1	HOL	Date of first holiday (H:01) displayed.
2	E	Press repeatedly to review single day holidays, H:01 - H:12. Press again to review H:13 - H:15, indicating the begin dates for both holiday durations. No colon will appear for H:14 and H:16, the duration end dates. Press again to review Daylight Savings Time dates.
3	CLR	Press this key if you discover that any date is incorrect. The title of the cleared holiday (H:01 - H:16) or Daylight Savings Time date (Spr or FaLL) will be displayed.
4	####	Enter correct month and date.
5	E	Enters new date into memory and advances to next holiday.
6	RUN	Time and day of week displayed. Colon flashing.
7	C1/C2	Switching of loads occurs only in the RUN mode. If an event was scheduled to occur while you were programming, the event will not have taken place if you were programming during the entire minute that the event was scheduled to occur. Press C1 or C2 to initiate override if the status of either circuit is incorrect.

MAINTENANCE

Cleaning — Do not use any type of cleaning agent on the liquid crystal display screen or front panel.

Control Removal — Any model can be removed from its case.

EC72 — See directions on page 11.

EC72D — The plug-in case of the DIN model allows removal of the control without disturbing the wiring. See pages 16-17 for terminal cover removal, then pull the control upward to snap it from the terminal block. *A moderate amount of force is required.*

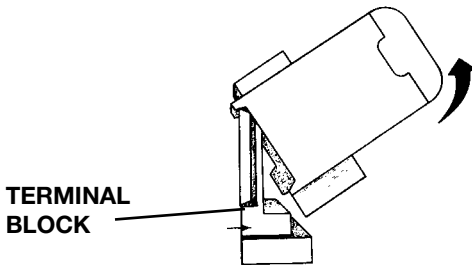

Figure 11. Removal of EC72D from Terminal Block

APPLICATIONS — LIGHTING

Objective: To control indoor lighting on Channel 1 and parking lot lights on Channel 2.

Sequence of Operation:

Channel 1 — Relay contacts 3 and 4 close to turn indoor lights ON during building's open hours. Relay contacts 3 and 4 open to turn indoor lights OFF during business closed hours.

Channel 2 — Relay contact 6 and 7 close to turn parking lot lights ON. Relay contacts 6 and 7 open to turn parking lot lights OFF.

Note that wiring diagrams differ for different models. Check product label to make sure you are using the correct wiring diagram.

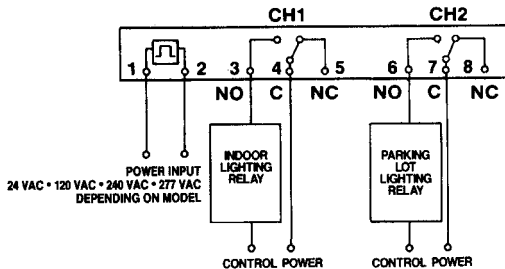

Figure 12. EC72 Wiring Diagram for Indoor and Outdoor Lighting

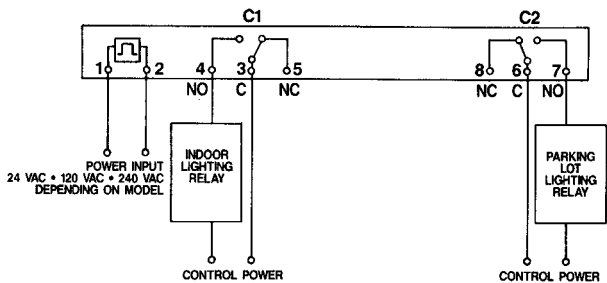

Figure 13. EC72D Wiring Diagram for Indoor and Outdoor Lighting

APPLICATIONS — HVAC

Objective: To reduce utility costs by time-of-day scheduling for night setback/setup and damper control. Use Channel 1 for daytime/night-time thermostat, Channel 2 for damper.

Sequence of Operation:

Channel 1 — Before occupancy of the building, the HVAC system is started when timer switches control from night thermostat to day thermostat. At or near end of occupancy, timer transfers control of HVAC system from day thermostat to night thermostat.

Channel 2 — Relay contacts 6 and 7 close, opening dampers during building open hours. Relay contacts 6 and 7 open, closing dampers during building closed hours.

Note that wiring diagrams differ for different models. Check product label to make sure you are using the correct wiring diagram.

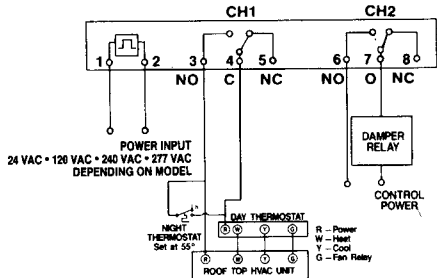

Figure 14. EC72 Wiring Diagram for Nighttime Setback and Damper Control

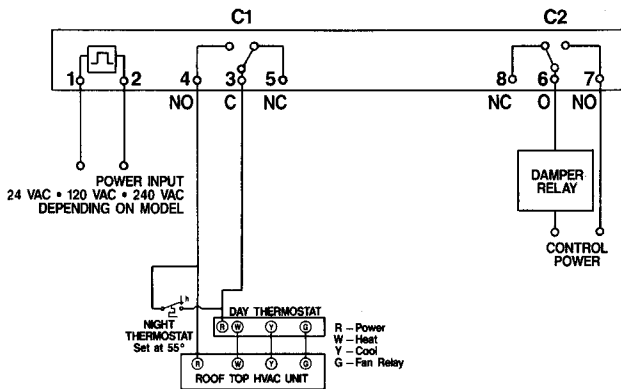

Figure 15. EC72D Wiring Diagram for Nighttime Setback and Damper Control

APPLICATIONS — SCHOOL BELLS

Objective: To ring school bells on a pre-programmed schedule. You must select the Momentary Option and clip the appropriate jumper wire. See pages 22-23.

Sequence of Operation:

At each scheduled event, the normally open contacts (3 and 4 for Channel 1, 6 and 7 for Channel 2) close for two seconds, ringing school bells. To eliminate Saturday and Sunday from daily schedule, program one event for each channel on each of those days. The bells will ring once on Saturday and once on Sunday at the programmed time. If one of the alternate wiring diagrams shown on pages 42 - 43 is used, the bells will not ring when Channel 1 and Channel 2 have events programmed for the same time as on Saturday and Sunday.

Note that wiring diagrams differ for different models. Check product label to make sure you are using the correct wiring diagram.

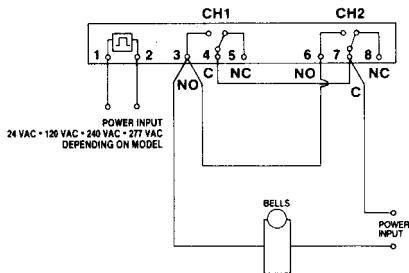

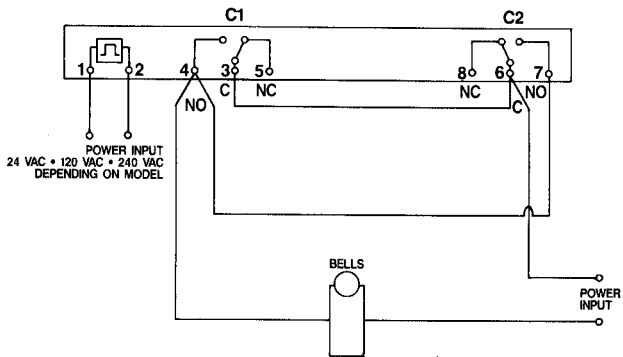

Figure 16. EC72 School Bell Wiring Diagram
Figure 17. EC72D School Bell Wiring Diagram

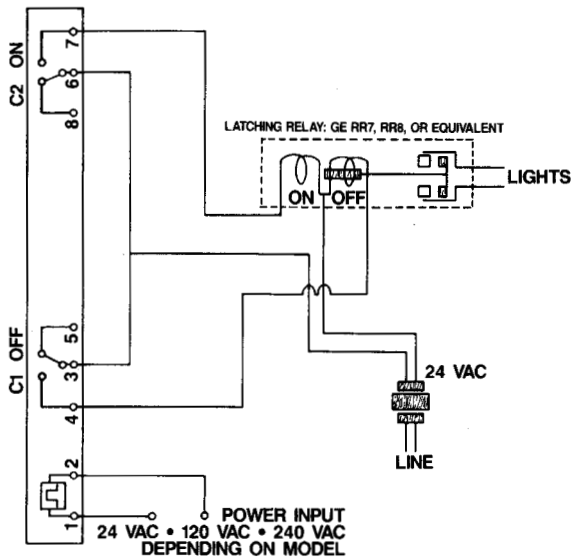

Figure 19. EC72D Latching Relay Wiring Diagram

APPLICATIONS

FOR MOMENTARY CONTROL ONLY

The following wiring diagrams allow the Daily Function to be used and still have a day without any events, even though the Momentary Option has been selected. See page 29.

To use the Daily Function on a momentary control and still obtain a day without any events, follow these steps:

1. Wire the control as shown below.
2. Program an event on both channels at the same time on the day that should have no events. Both relays will energize at the same time, canceling each other out.

Note that wiring diagrams differ for different models. Check product label to make sure you are using the correct wiring diagram.

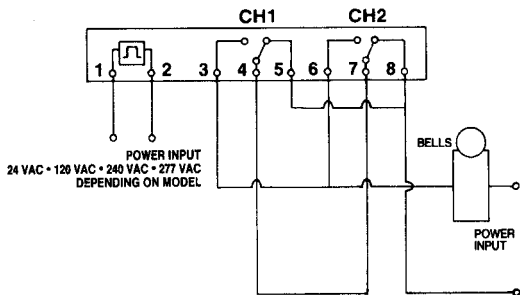

Figure 20. EC72 School Bell Alternate Wiring Diagram

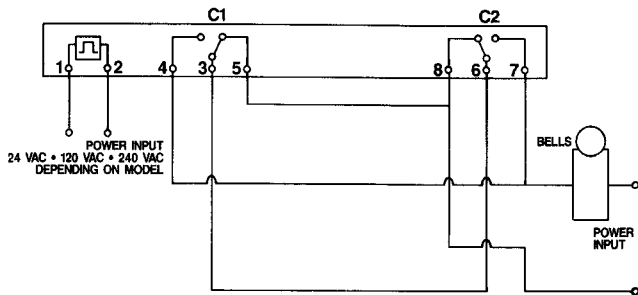
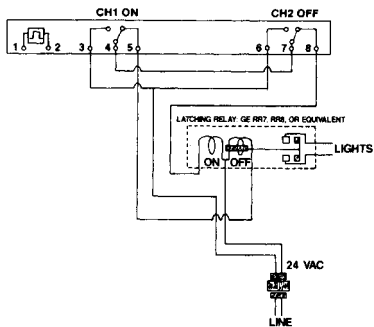
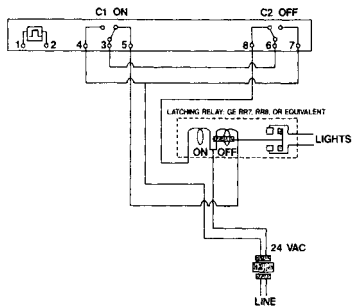

Figure 21. EC72D School Bell Alternate Wiring Diagram

**Figure 22. EC72
Latching Relay
Alternate Wiring
Diagram**



**Figure 23. EC72D
Latching Relay
Alternate Wiring
Diagram**



TROUBLESHOOTING TIPS

Problem	Solution
Nothing happens when a setpoint occurs to turn a load ON or OFF.	<ul style="list-style-type: none">• Review programmed setpoints making sure the day has not been skipped.• Check input power to control.• Ensure the clock is not in a holiday period.• Check if manual override changes the load's state. If it does not, see next problem/solution.
Manual override does not work.	<ul style="list-style-type: none">• Check the load for proper wiring. Remember, EC72 contacts switch only what is applied to them (dry or isolated contacts).
Clock display is locked up, garbled or meaningless.	<ul style="list-style-type: none">• Disconnect battery and input power to the control for 1 minute. Re-apply power and reprogram.
Blank Display	<ul style="list-style-type: none">• Check input power source and battery if installed. Ensure proper connections of wiring.
Control does not operate after programming.	<ul style="list-style-type: none">• If programming was performed (changing clock time or entering a setpoint), the control will not update itself. Press either C1 or C2 to override the load until the next scheduled setpoint.
When programming a setpoint, no indication of the type of event is given.	<ul style="list-style-type: none">• If J1(EC72) or J29(EC72D) has been cut, the EC72 now is fixed at a 2 second event duration. There is no indication of the type of event since all events are now momentary.

GLOSSARY

7-Day Programming — programming that repeats a schedule every 7 days

8th Day — any of a number of designated holidays that follow a unique schedule, programmed with Key 8 instead of weekday Keys 1-7

Battery Carryover — a feature that maintains time and programming during power outages but does not power the loads

Channel — an independently programmable output

Daily Event — an event that occurs every single day, programmed with Key 0 instead of weekday Keys 1-7

DIN — a European-style mounting system for electrical controls; the DIN rail is fixed to a panel, while the control is snapped onto the rail; the control can be removed when necessary

Dry Contact — a contact that operates as a simple switch; voltage must be supplied to the contact in order to power the load

Event — a change in operation (i.e. switching ON or OFF)

Holiday — any day that will follow a separate, unique schedule assigned to all such days

Load — a device that receives power (e.g., lights)

Manual Override — a feature that reverses current programming; loads that are ON turn OFF, loads that are OFF turn ON

Relay — a magnetically operated switch

Repeat Programming — a feature that employs the daily Key 0 to increase the number of available events from 16 per channel to 112 per channel

Setpoint — a programmed entry that defines the type of event as well as the time and the day(s) on which the event will occur

INDEX

- Accuracy, 7
- Application, 34 - 44
- Back mounting plate, 14
- Battery, 8, 12, 15
- Channel Indicators, 19
- Cleaning, 33
- Clock format, 19, 24
- Daily events, 20, 29
- Day of week, 19, 24
- Dimensions, 8, 9
- DIN rail, 8, 14
- Display panel (screen), 19
- Dry contact, 17, 46
- Environmental, 8
- Glossary, 46
- Holidays, 21, 30
- Input, 13, 16
- Installation, 11, 14
- Keyboard description, 19
- Maintenance, 33
- Momentary Option, 5, 22-23
- Mounting, 11, 14
- NEMA, 5, 8, 11
- Output, 7
- Override, 29
- Power outage carryover, 8
- Power requirements, 7
- Programming Capabilities 6, 20 - 21
 - To change programming, 25, 28, 32
 - To review programming, 25, 28, 32
 - To understand programming, 20-21
 - To program -
 - Date, 24
 - Day of week, 24
 - Daylight Savings Time, 30
 - Daily Events, 20, 26, 29
 - Events, 26
 - Holidays, 21, 30
 - Time of Day, 24
- Repeat Programming, 21
- Specifications, 7
- Terminal block, 33
- Terminal cover, 16
- Terminals, 13, 17
- Time of day, 19, 24
- Time/Date/Day indicator, 19
- Troubleshooting, 45
- Warranty, 2
- Weight, 8
- Wiring, 13, 16
- Wiring diagrams, 34-44



Maple Chase Company
2820 Thatcher Road
Downers Grove, Illinois 60515
Made in Mexico

Paragon Electric Canada, Ltd.
5785 Kennedy Road
Mississauga, Ontario L4Z 2G3

Customer Service 800-951-5526
Technical Support 800-732-8400

From outside North America
630-719-5500

ISO 9002 registered

Part Number 110-703B
