



ET100 SERIES

Electronic 24 Hour Time Switches

With Battery Carryover

INCLUDING MODELS:

ET101C (SPST)

ET103C (DPST)

ET105C (SPDT)

OWNER/INSTALLER INSTRUCTION MANUAL

ATTENTION: READ CAREFULLY BEFORE ATTEMPTING TO INSTALL YOUR INTERMATIC TIME SWITCH. FAILURE TO COMPLY WITH INSTRUCTIONS COULD RESULT IN PERSONAL INJURY AND/OR PROPERTY DAMAGE! RETAIN FOR FUTURE REFERENCE.

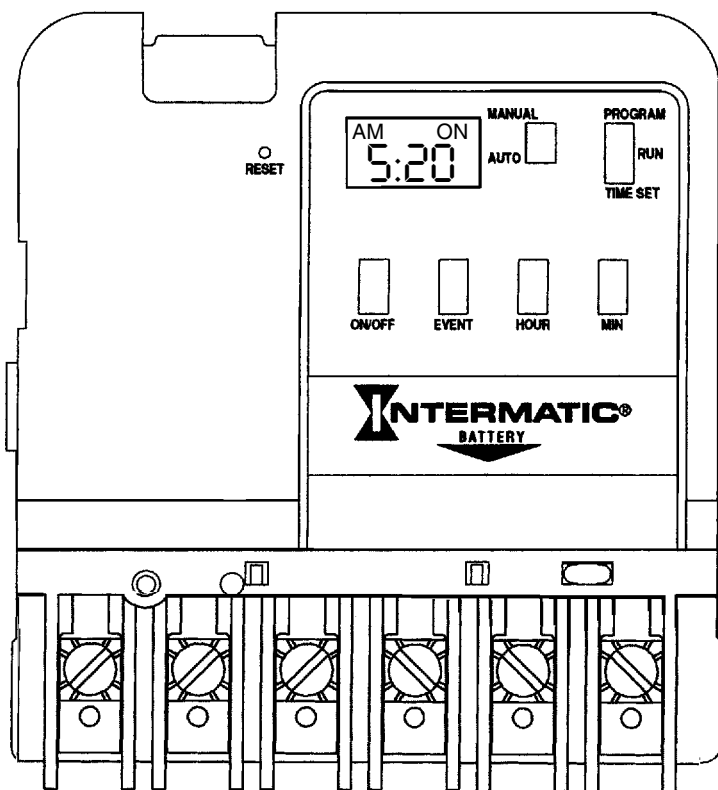

Specifications

CLOCK VOLTAGE: 120 V.A.C., 60 Hz.

POWER CONSUMPTION: 3.0 Watts Max. (ET101C) & (ET105C)

5.0 Watts Max. (ET103C)

CONTACT CONFIGURATION: SPST model ET101C DPST model ET103C, & SPDT model ET105C.

SWITCH RATING: (Per Pole for ET103C)

- 30 Amps Inductive/Resistive, 24/120/240 V.A.C., 60 Hz.
- 20 Amps Resistive - 28 V.D.C.,
- 1 H.P. 120 V.A.C., 60 Hz.
- 2 H.P. 240 V.A.C., 60 Hz.
- 5 Amps Tungsten, 120/240 V.A.C., 60 Hz.
- 20 Amps Ballast 277 V.A.C., 60 Hz.

SWITCH RATINGS: ET105C

N.O.	N.C.	CONTACT	
20 AMP	10 AMP	Resistive and General Purpose	28 VDC. 120-240 VAC
1 H.P.	1/4 H.P.	MOTOR	120 V.A.C.
2 H.P.	1/2 H.P.	MOTOR	240 V.A.C.
5 Amp	-	TUNGSTEN	120-240 V.A.C.
20 Amp	3 Amp	BALLAST	120-277 V.A.C.

SET POINTS (EVENTS): 8 total (4 ON/4 OFF).

BATTERY POWERED CLOCK OPERATION: 3 Years minimum (AA industrial grade alkaline supplied with time switch)

MIN. "ON" or "OFF" TIME: 1 minute.

MAX. "ON" or "OFF" TIME: 23 hours 59 minutes.

SHIPPING WEIGHT: 2,5 Lbs. (1.1 Kg)

CASE: Drawn steel; 7-3/4" (19.7 cm) high, 5" (12.7 cm) wide, 3" (7.6 cm) deep; gray finish w/lockable spring hasp.

KNOCKOUTS: Combination 1/2 - 3/4" (one on back and each side, two on bottom).

WIRE SIZE: AWG #10 through #18.

Description

The Intermatic Electronic 24 Hour Time Switch automatically switches loads according to a preset daily schedule. This time switch is designed to directly switch loads up to 30 amps and to switch resistive or inductive loads up to the time switch rating. For use as a control timer in applications requiring 24 hour load control such as lighting, heating, air conditioning systems, pumps, etcetera. Up to eight set points or events (4 ON/4 OFF) can be preset. this schedule will repeat on a daily basis. The program can be overridden by using the MANUAL position.

General Safety Information

WARNING: Disconnect all power before installing or servicing this time switch or its connected loads.

1. Follow all local electrical and safety codes, National Electric Code (NEC), as well as Occupational Safety and Health Act (OSHA).
2. If the power disconnect point is out of sight, lock it in the "OFF" position and tag it to prevent unexpected application of power.
3. This time switch case must be grounded.
4. Do not exceed the maximum current carrying capacity of this time switch.
5. Always replace the plastic insulator covering the terminal before turning power "ON".

Installation

WARNING: DISCONNECT THE POWER TO THE TIME SWITCH AND THE LOADS BEFORE INSTALLING THIS TIME SWITCH.

1. Mount the time switch in the desired location using the three mounting holes which are provided. Mount the time switch at eye level, if possible, providing sufficient room to the left of the enclosure for the cover to swing open fully. (See Figure #1 and Figure #2). The time switch mechanism does not need to be removed from the enclosure to mount the time switch since the top mounting hole is a slotted type mounting hole. Secure a screw or other fastener at eye level. The head of the screw or fastener should be slightly larger than the narrow portion of the slotted hole to ensure that the time switch is securely held in place. The remaining two mounting holes are accessible without removing the time switch mechanism and will provide secure and permanent mounting of the time switch.

2. If you do remove the mechanism, refer to Figure #1 and remove the mechanism from the case by depressing the catch at the top of the case and pulling out.

CAUTION; DO NOT TOUCH THE CIRCUIT BOARD COMPONENTS SINCE STATIC DISCHARGE COULD DAMAGE THE MICROPROCESSOR.

3. Replace the mechanism in the case if it has been removed.

4. Lift the left side of the insulator off of the retaining post and pivot it up and away to expose the terminal strip.

5. Strip the supply and load wires by removing 1/2 inch of insulation. **DO NOT USE ALUMINUM WIRE.** (See figure #3, #4 or #5). Insert the wire ends under the proper terminal plates and tighten the screws firmly. Use AWG #10 through #18. Connect ground wire to grounding terminal at bottom of case.

6. Replace the plastic insulator.

7. Be sure that the battery is functioning properly. this can be checked by making sure the display is visible. If the display has scrambled information, press the RESET switch and hold for three to five seconds. Note that the battery can easily be replaced without removing the time switch mechanism or field wiring. simply press in and downward (in the direction of the arrow) on the battery cover which is identified with the word "Battery". It is recommended that the battery be replaced with a "AA" industrial grade alkaline cell at two to three year intervals as part of the normal time switch maintenance observing battery polarity markings when installing. No other maintenance is required.

8. Place the selector switches in the "MANUAL" and "RUN" positions.

9. Reapply power to the time switch.

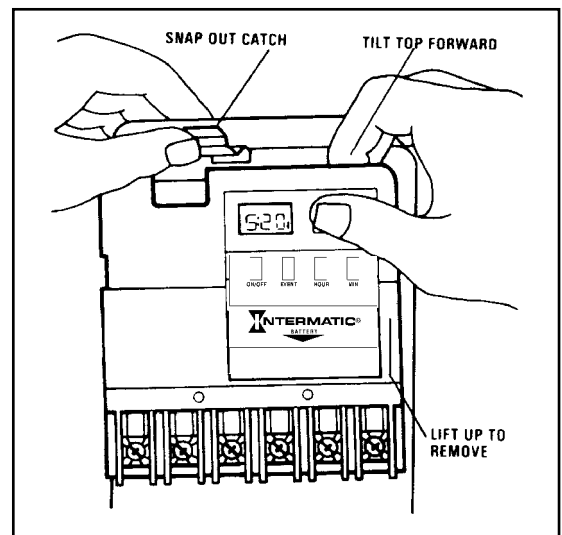

FIG. #1

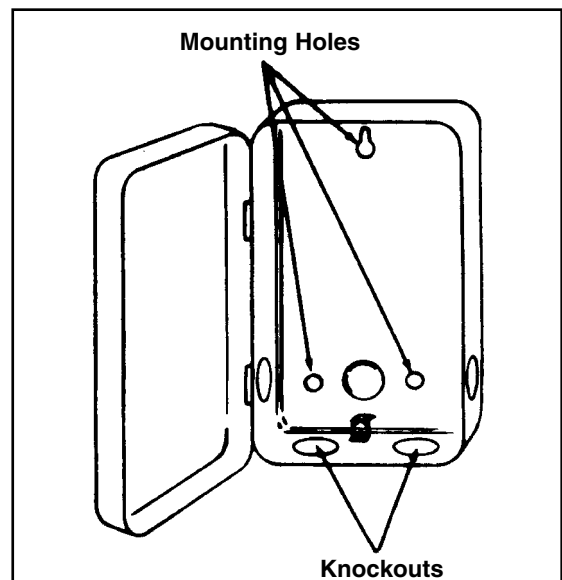

FIG. #2

NOTE: For 120 Volt loads only since the timer voltage is 120 VAC a jumper can be added between terminals 2 and 3 to supply load power.

CAUTION: Do not use jumper if load(s) are not 120V. because the load can be damaged. Supply separate power of the correct voltage to terminal 3.

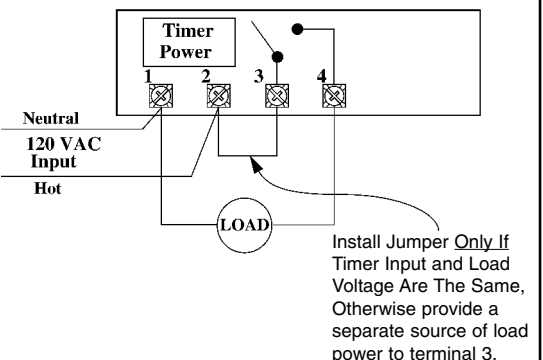

FIG. #3
ET101C SPST

10. Press the reset switch for three to five seconds. The display will now show 12:00 A.M. and Event #1. The timer is now ready for programming. Refer to the chart below and enter the scheduled events (set points) required.

EVENT	TIME
On 1	_____
Off 2	_____
On 3	_____
Off 4	_____
On 5	_____
Off 6	_____
On 7	_____
Off 8	_____

Programming Steps

Refer to programming instructions on time switch door label and note the following:

- The MANUAL/AUTO selector can be used to temporarily override the program. Under normal operation the selector should be in the AUTO mode. The MANUAL mode maintains the program but prevents the loads from automatically switching.
- The other selector switch is used to set the time of day (TIME SET), the program information (PROGRAM) or to run the program (RUN). **FOR A PROGRAM TO FUNCTION PROPERLY, THE TWO SELECTOR SWITCHES MUST BE IN THE AUTO AND RUN POSITIONS.**
- The RESET switch is used only prior to initially programming the time switch or to erase all programmed set points.
- By holding the hour and/or minute buttons depressed you can achieve a fast roll of the displayed time. This is useful when setting the time of day or setting the programmed set points (events).
- Up to 4 ON and 4 OFF set points (8 events) can be programmed.
- The load can manually be switched ON or OFF at any time only if the selector switch is in the RUN mode by pressing the ON/OFF button.
- Pressing the ON/OFF button two times in the PROGRAM mode causes the event time displayed to be removed from the program. The display will show 0:00 and the Event (1 through 8).

To Operate Timer

After programming is complete, move the selector switches to the RUN and AUTO positions. The time switch will follow the scheduled program but will not immediately "catch up" to the presently programmed load condition; the time switch will "catch up" at the next scheduled ON or OFF setpoint. If necessary, press the ON/OFF button to turn the load on or off.

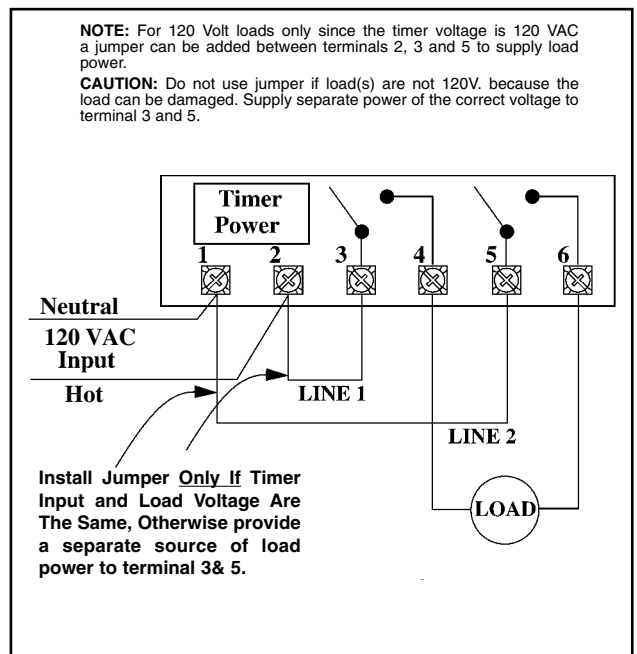

FIG. #4
ET103C DPST

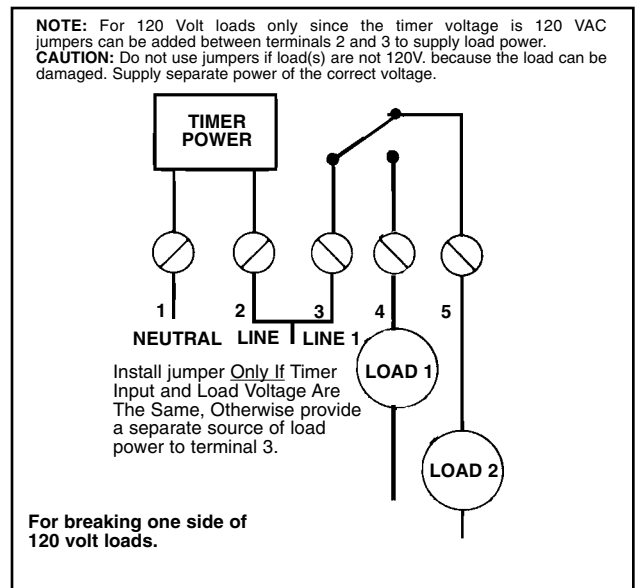

FIG. #5
ET105C SPDT

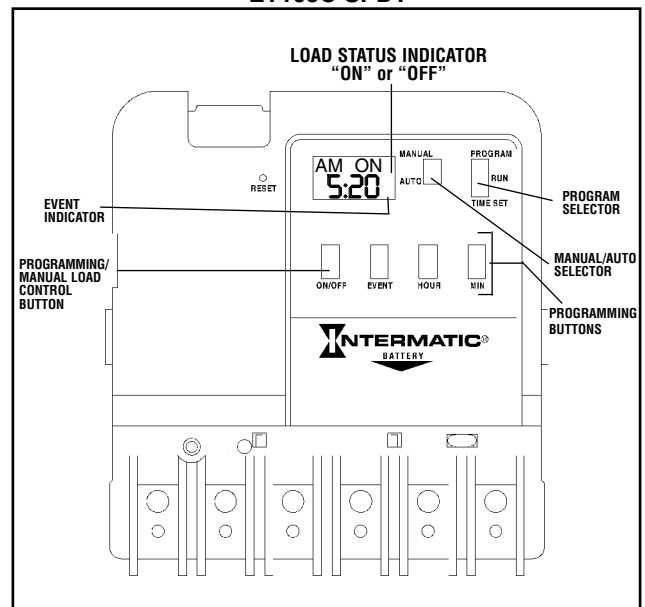

FIG. #6

Trouble Shooting

SYMPTOM	POSSIBLE CAUSE(S)	CORRECTIVE ACTION
Time switch has no display.	Battery not properly installed or defective.	Check battery and replace if necessary.
Display shows "L-bA".	Display means "Low Battery".	Replace battery within 30 days.
Display shows "Err 1" message. Display shows "Err 2" message. Display shows "Err 3" message.	Slide switch not fully in its detent position (open circuit). Slide switch shorted circuit. Slide switch illegal position.	Reposition slide switch into detent or "wiggle" until display is corrected. If display does not correct, contact or return to factory for service.
Display shows scrambled or erratic times.	Time switch has not been reset. Electrical noise is interfering with the operation of the microprocessor.	Press the recessed reset switch and hold for approximately 5 seconds. Electrical noise interference is highly unlikely since the electronic circuitry and the power supply are completely isolated. The installation of surge suppressors (metal oxide varistors-MOVs) across terminals 3/4 (model ET103C across terminals 3/4 & 5/6) will help to reduce electrical noise generated at the switching contacts.
Load does not switch at programmed time.	MANUAL/AUTO selector not in AUTO position. Time switch is programmed incorrectly Power has not been supplied to the load through the line (line 1 and line 2 for ET103C) terminals.	Be sure MANUAL/AUTO is in the AUTO position. Check program - place the Program Selector in the PROGRAM mode and press the Event button to review all eight possible Events. Be sure power is applied to the line terminals #3 (#3 and #5 for ET103C) in order to power the load. Note that the output contacts are isolated from the timer power (terminals 1 and 2). This allows the timer to switch various loads

LIMITED ONE YEAR WARRANTY

If within one (1) year from date of purchase, this product fails due to a defect in material or workmanship, Intermatic Incorporated will repair or replace, at its sole option, the unit free of charge. This warranty applies only to the original purchaser and is not transferable.

The warranty does not apply to: (a) damage caused by accident, abuse, mishandling, dropping, acts of God, or any negligent use; (b) units which have been subject to unauthorized repair, opened, taken apart, or otherwise modified; (c) units not used in accordance with directions; (d) damages exceeding the cost of the product. Some states do not allow a limitation of damages, so the foregoing limitation may not apply to you.

This warranty gives you specific legal rights and you may have other rights that vary from state to state.

INTERMATIC INCORPORATED WILL NOT BE LIABLE FOR INCIDENTAL OR CONSEQUENTIAL DAMAGES. THIS WARRANTY IS IN LIEU OF ALL OTHER EXPRESS OR IMPLIED WARRANTIES. ALL IMPLIED WARRANTIES, INCLUDING THE WARRANTY OF MERCHANTABILITY AND THE WARRANTY OF FITNESS FOR A PARTICULAR PURPOSE, ARE HEREBY MODIFIED TO EXIST ONLY AS CONTAINED IN THIS LIMITED WARRANTY AND SHALL BE OF THE SAME DURATION AS THE WARRANTY PERIOD STATED ABOVE.

This warranty service is available by either (a) returning the product to the dealer from whom the unit was purchased, or (b) mailing postage pre-paid to the nearest authorized service center listed. Please be sure to wrap the product securely when mailing to avoid damage. This warranty is made by: Intermatic Incorporated/After Sales Service, 7777 Winn Rd., Spring Grove, IL 60081-9698.

SERVICE CENTER/ SERVICE CENTRE CENTRE DE SERVICE

INTERMATIC INCORPORATED
After Sales Service
7777 Winn Rd.,
(815) 675-7000

<http://www.intermatic.com>

INTERMATIC INCORPORATED
SPRING GROVE, ILLINOIS 60081-9698