

# Operating Instructions

## TimeMaster

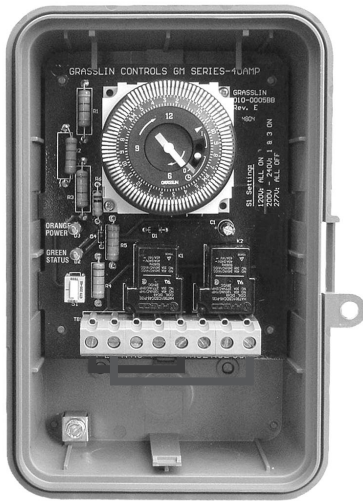

NEMA 3R Enclosure



File #E83486  
Covered by U.S. Patent #6,563,237.1.

Bracket Mount with Dimensions

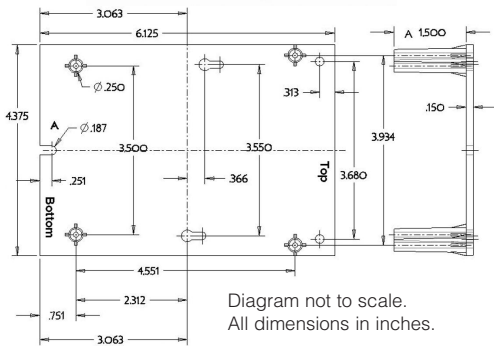
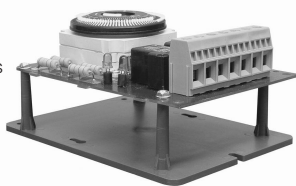

## GM40 General Purpose Multi-Voltage Commercial Time Switch

### INSTALLATION

1. Open door and then remove interior protective cover by releasing spring clip on bottom.
2. Remove timer mechanism by releasing spring clip on bottom.
3. Select knockouts to be used. Remove inner 1/2" knockout by inserting a screwdriver in the slot and carefully punch knockout loose. Remove slug. If 3/4" knockout is required, remove the outer ring with pliers after removing the 1/2" knockout. Smooth edges with knife if necessary.
4. Place enclosure in desired mounting location and mark the three mounting holes (refer to diagram). Start by placing set screw on top and attaching enclosure over keyhole; then screw in remaining two screws on bottom.
5. Connect conduit hubs to conduit before connecting the hubs to the enclosure. After inserting hubs into enclosure, carefully tighten hub lock nut. Do not over-torque.
6. Verify input voltage selection. Refer to DIP switch diagram for desired input voltage.
7. Wire in accordance with National and Local Codes (see wiring diagrams).
8. Grounding: Terminate all ground wires to ground lug on bottom of enclosure.
9. Replace interior protective cover.

**Note:** For outdoor locations, raintight or wet location conduit hubs that comply with requirements of UL 514B (standard for fittings for conduit and outlet boxes) must be used.

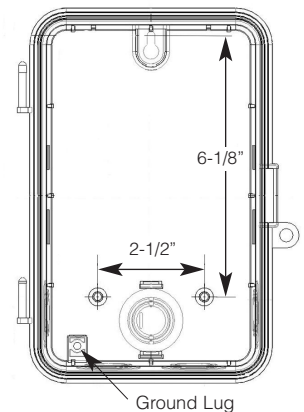
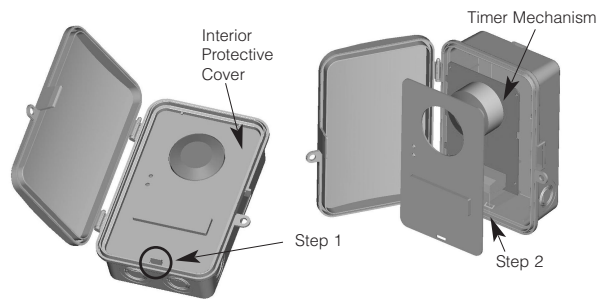

### ELECTRICAL RATINGS:

#### N.O. Contacts:

- 40A Resistive @ 120~277VAC
- 1HP, 16FLA, 90LRA @ 120VAC
- 2HP, 12FLA, 52LRA @ 208~277VAC
- 30A Ballast @ 120VAC
- 20A Ballast @ 277VAC
- 15A Tungsten @ 120VAC
- 300VA Pilot Duty 120~240VAC

#### N.C. Contacts:

- 30A Resistive @ 120~277VAC
- 1HP, 12FLA, 30LRA @ 120VAC
- 2HP, 10FLA, 30LRA @ 240VAC
- 2A Tungsten @ 120VAC
- 10A Ballast @ 277VAC

### WIRING CONNECTIONS:

Screw box lug terminals

### ENVIRONMENTAL RATINGS:

Operating Temperature Range:  
-40°F to 131°F (-40°C to 55°C)  
Operating Humidity: 0 to 95% non-condensing

### ENCLOSURE DIMENSIONS:

8.795" x 6.631" x 2.935" (H x W x D)

### SHIPPING WEIGHT: 2 lbs.

### INPUT VOLTAGE DIP SWITCH SETTING:

1. Do not apply power to the GM40 prior to setting correct Input Voltage DIP switch.
2. Determine the input voltage which will be applied to the GM40 (i.e. L1 and L2/N terminals, see wiring diagrams).
3. Set the DIP Switch according to the diagram below.

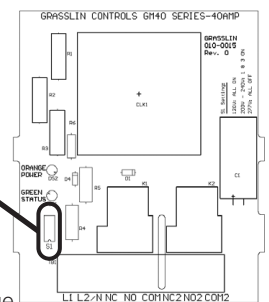
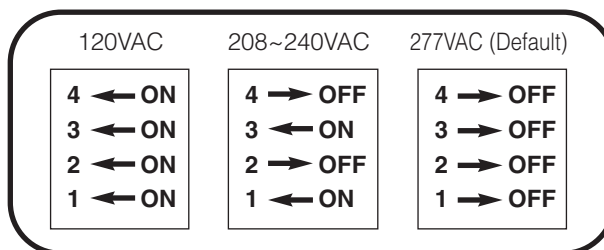

**NOTE:** Unit is shipped with DIP Switches set for 277VAC Input Voltage.  
**CAUTION:** Do not check circuits by "sparking" wires to terminals. Damage to the timer may result.

**APPLICATION**

The GM40 Multi-Volt Series Time Controls are universal, electromechanical time switches which can be field configured for various power supply voltages. The voltage options include 120VAC, 208/240VAC and 277VAC –all within the same unit! Selection of the desired supply voltage is easily achieved by selecting the DIP to the corresponding input voltage as indicated on the printed circuit board assembly (refer to “input voltage selection” on page 1). The mechanism is mounted in a NEMA 3R outdoor enclosure and has been design for the control of lighting, heating, air conditioning, pumps, motors, or general electrical circuits in residential, commercial, industrial and agricultural facilities. All GM40 models are available as “Mechanism Only” (-M) for installation in other enclosures or control panels or “Bracket Mount” (-B). The GM40 is also available in a NEMA 1 Indoor Metal Enclosure (-IM).

**SPECIFIERS GUIDE**

Furnish and install a Grasslin GM40 \_ Multi-Volt Series 24 hour or (7 day) time switch with captive trippers and quartz or synchronous drive. Input voltage shall be 120, 208/240 or 277VAC selectable via simple to set DIP switch. All units shall incorporate both SPDT and DPDT contacts that shall be rated at 40A, 2 HP @ 277V. To set the starting time and to provide time indication, the unit shall have an authentic clock face with hour and minute hands. LED indicators shall provide Power and Status feedback. Enclosure shall be NEMA 3R suitable for

both indoor or outdoor installation. Time switch shall contain an OFF/AUTO/ON manual override. For Carry-over: The time switch shall have a quartz drive with 7 day reserve carry-over.

**PROGRAMMING INSTRUCTIONS**

**SETTING THE TIME:** Rotate the program dial gradually clockwise until the day of the week (7 day) and time of day on the outer dial is nearly aligned with the triangle marker at 2 o'clock position. Then set time to the minute by rotating minute hand clockwise. **CAUTION:** Do not rotate dial or minute hand counter-clockwise.

**PROGRAMMING:** The 24 hour model has trippers of 15 minute increments, and an AM/PM indication on the outer dial. The 7 day model has trippers of 2 hour increments. The outer dial shows the 7 days of the week and AM/PM for each day. Push the captive trippers outward for the time period(s) that the load is to be on (Normally open contacts closed).

**MANUAL OVERRIDE:** With the manual switch in the middle position, the GM40 is in automatic mode and will switch at the programmed times. In the upper position “I”, the load is permanently ON. In the lower position, “O”, the load is permanently OFF.

**BATTERY POWERED RESERVE (Quartz Models):**

In case of power failure, the built-in nickel-cadmium battery maintains the time of day for 7 days. During power outage relays are de-energized.

The GM40 is the only electromechanical general purpose time switch that offers multi-voltage selection, SPDT and DPDT contacts, 40Amp rating, indoor and outdoor enclosure – all standard in one model.

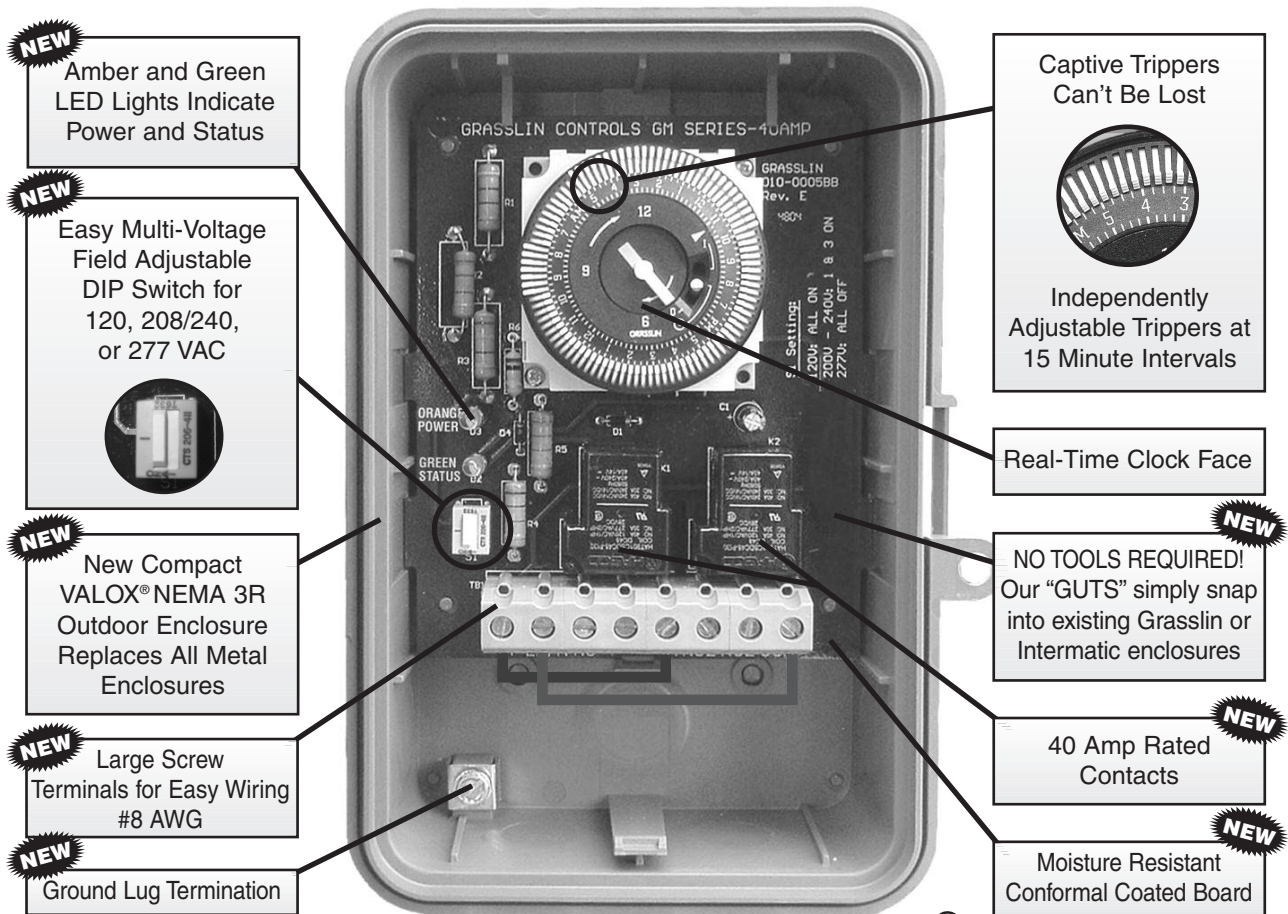

**GM40 – 120, 208/240, or 277 Volts – The only one to stock.**

 File #E83486  
Covered by U.S. Patent #6,563,237

# GM40 TERMINAL DESIGNATIONS

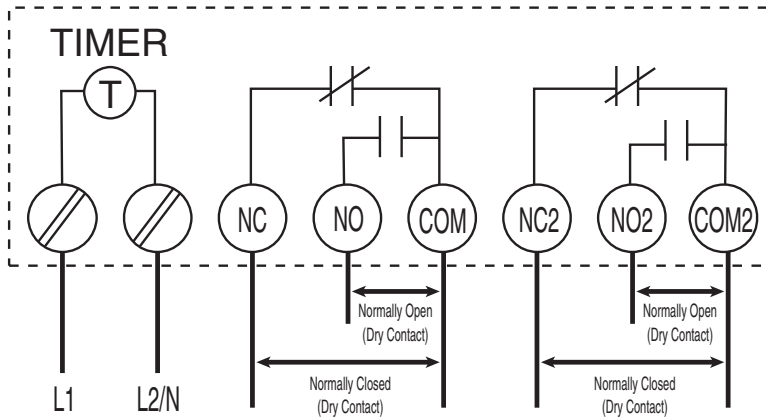

**Note:** GM40 is shipped with pre-installed jumper wires (L1 to COM and L2/N to COM2). In applications requiring a “DRY” non energized contact, remove jumpers as shown.

## GM40 TYPICAL WIRING DIAGRAMS

Typical Wiring Diagram (120VAC Application)  
Controlling One 120VAC Load

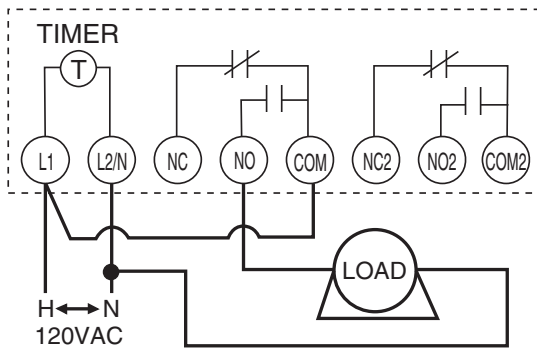

If GM40 is used to control a single 120VAC load, remove jumper wire (L2/N to COM2) and keep jumper wire (L1 to COM).

Typical Wiring Diagram (120VAC Application)  
Controlling Two 120VAC Loads

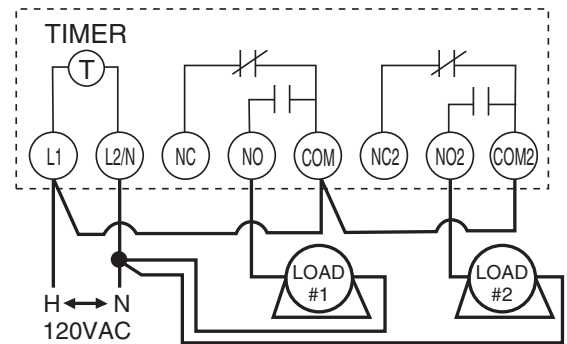

If GM40 is used to control two 120VAC loads, remove jumper wire (L2/N to COM2) and reposition it to (COM to COM2).

Typical Wiring Diagram (240VAC Application)  
Controlling One 240VAC (Dual Phase) Load

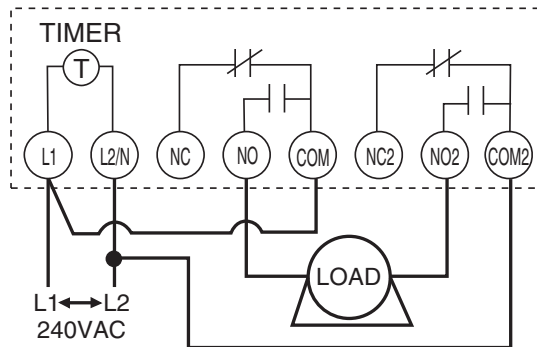

If GM40 is used to control a single 240VAC load, do not remove jumper wires (L1 to COM and L2/N to COM2).

Typical Wiring Diagram (277VAC Application)  
Controlling Two 277VAC Loads

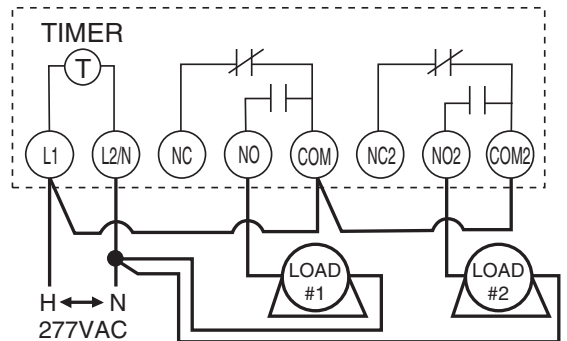

If GM40 is used to control two 277VAC loads, remove jumper wire (L2/N to COM2) and reposition it to (COM to COM2).

Note: Refer to page 1 for proper Input Voltage DIP Switch selection.

# GM40 TROUBLESHOOTING GUIDE

## PROBLEM: LOAD (Lights/Pumps/Motor, etc.) does not turn ON

1. Check AMBER Power LED, if ON it indicates power is applied to GM40.
2. Verify correct input voltage DIP switch setting (refer to page 1).
3. Check voltage across terminals L1 and L2/N with Multi-meter.
4. Slide manual override switch (locate on right side of timer module) up. The GREEN LED should illuminate indicating that the output should be ON.
5. Check wiring (refer to page 3).

## PROBLEM: LOAD (Lights/Pumps/Motor, etc.) does not turn OFF

1. Verify manual override switch is set to the middle position.
2. Verify correct programming dial (refer to page 2).
3. Slide manual override switch (located on right side of timer module) down. The GREEN LED should turn OFF indicating that the output should be OFF.

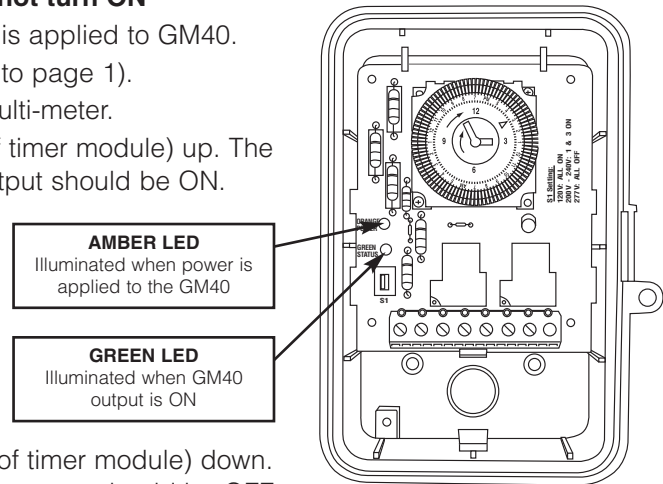

## GM40 CONTACT TERMINALS TRANSITION

White arrow on timer module points to current time.



Trippers are "IN"  
Indicates  
Output is OFF  
GREEN LED - OFF

Status of Contacts

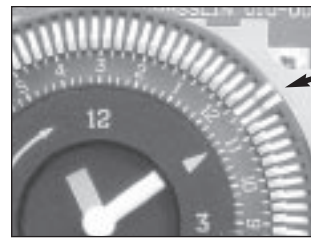
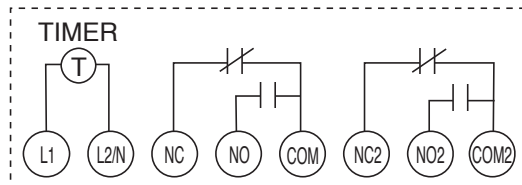

Trippers are "OUT"  
Indicates  
Output is ON  
GREEN LED - ON

Status of Contacts

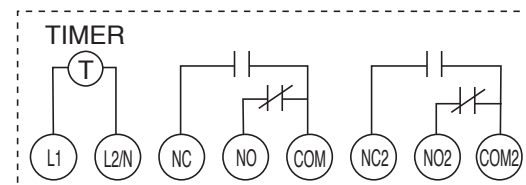

Note: Power must be applied across terminals L1 and L2/N in order for contacts to transition.

## GM40 MOUNTING INTO INTERMATIC ENCLOSURE

### Mounting GM40 Mechanism into existing Intermatic Metal Enclosure

The GM40 Series printed circuit board assembly will fit into all Intermatic enclosures except the T7000 and T5000 Series. Install GM40-M into Intermatic enclosure in the same manner as the Intermatic mechanism was previously installed.

