

White Rodgers Guardian PowerVent Intelli-Vent™ Sequence of Operation

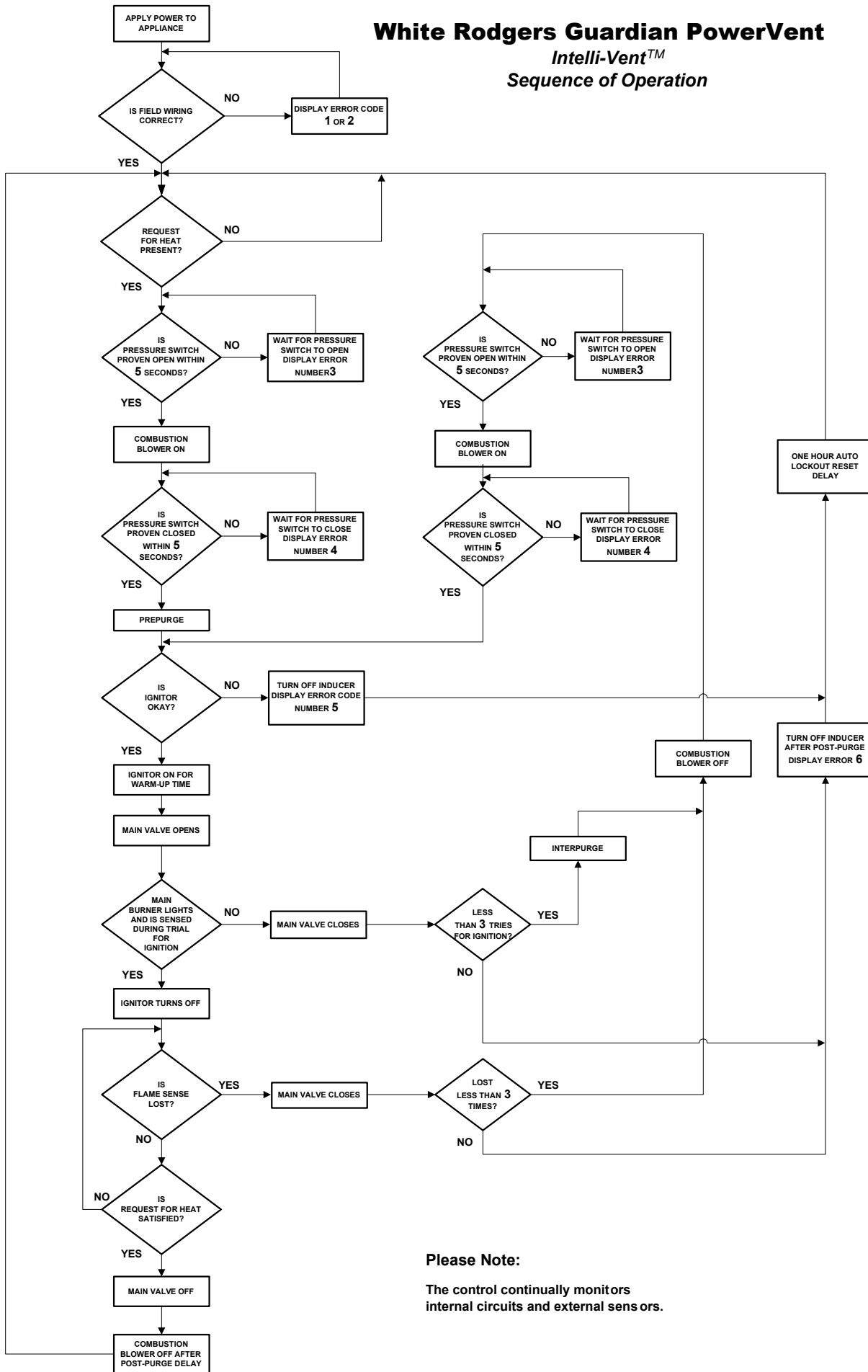

Please Note:
The control continually monitors internal circuits and external sensors.

Apply Power to the Water Heater

- Is the field wiring correct?
- Polarity correct
- Must have earth ground
- GFI Circuits are OK

Green lead to green grounding screw or wire
White Lead
Black Lead
Neutral
Line

1

Apply Power to the Water Heater

- Verify 120 VAC line voltage to control between 1 & 2



2

Request for Heat

- Control conducts self check for
 - ECO
 - Thermistor
 - Ignitor resistance
 - FV sensor
 - Self diagnostics
- Verifies venting is free and clear via the pressure switch

3

Turn on Inducer

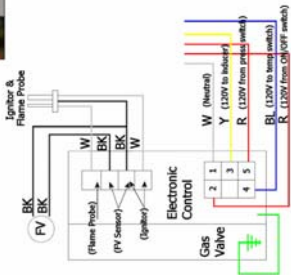



- Verify 120V to inducer on yellow line between 1 & 3
- You should hear blower on

4



Inducer comes on

- Is the inducer running?
 - Pushes exhaust gas thru venting
 - Add dilution air to cool gas to work in PVC pipe



5

Verify Pressure Switch/ Temp Probe Works

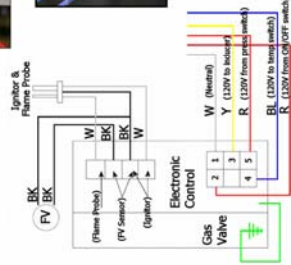
- Verify power to over temp switch on blue line (you should hear inducer running) between 1 & 4

6

Verify Pressure Switch/ Temp Probe Works

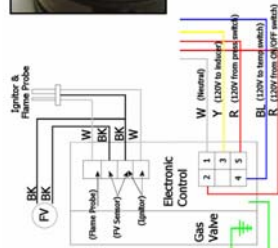

- Verify 120V from pressure switch on red line between 1 & 5
- Verifies venting is free and clear because switch operates properly

7

Proving the Inducer & Pressure Switch Works

- Vent tubing is not kinked
- Vent over-temp switch is not activated
- 0.75 inches w.c. on tube
- Pressure switch will not open
- Pressure switch will not close



8



Try for Ignition

- Is the hot surface ignitor present?
- Is the ignitor circuit with resistance limits? (11.5 to 18.8 ohms)
- Does the hot surface ignitor glow?
- Three attempts for flame rectification
- Then lock out on Max Ignition Attempts

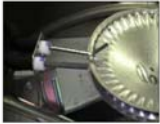

9

Ignitor Current



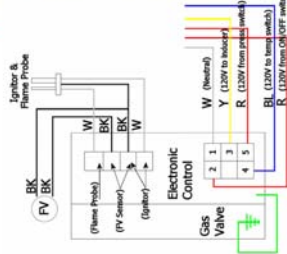

- Verify voltage to the ignitor here
- Should be between 70 - 90 VAC



10

Main Burner

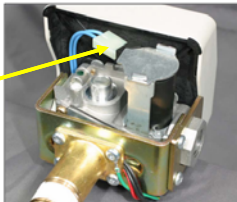
- Gas valve opens
- Main burner comes on
- Remember – there is no pilot of any kind with the White Rodgers system!
- Measure for @ 105 volts DC to verify power to the gas valve solenoid



11

Main Burner Flame Performance

- Water is heated to thermostat setting
- Flame probe monitors flame presence
- Flame is rectified at @ 4 micro amps DC
- Clean flame probe with steel wool if needed

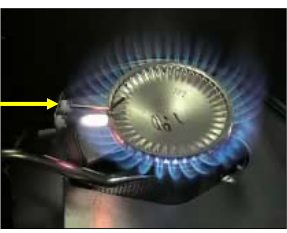

12

Monitoring Safety Performance



- Blower motor over temp switch is monitoring venting temperatures



- Flammable Vapor sensor is constantly monitoring ambient air for flammable vapors



- ECO is monitoring water temp

13

Thermostat is Satisfied

- Thermostat is satisfied
- Suspends power to the ignition circuit
- Blower motor conducts post purge
- Water heater in stand by



- FV Sensor is constantly monitoring ambient air – even when the burner is OFF!



14

Agenda



- Invensys to White Rodgers Control
- Appearance and connections
- Control Specifications
- Sequence of Operations
- Troubleshooting Flash Codes
- Removal, Replacement, Conversions



15

Lockout and Resets

- Timed lockout resets after 1 hour
- 3 auto resets max; then hard lockout
- Hard lockout – must cycle power to the control to reset (human intervention)
- Permanent lockout – Flammable vapor sensor or control failure
- 7 of 15 errors caused by “Internal Diagnostics” failures

7). GAS VALVE CIRCUIT ERROR	ON	OFF	OFF	OFF	ON	ON
8). DATA RETENTION ERROR	ON	OFF	ON	ON	ON	OFF
9). INTERNAL FAULT / POWER UP	ON	ON	ON	ON	ON	ON
11). OPEN ECO	ON	OFF	OFF	ON	ON	ON
12). TEMP. ADJ. BUTTON STUCK CLOSED	ON	OFF	ON	ON	OFF	OFF
13). OPEN / SHORTED THERMISTOR	ON	OFF	ON	ON	OFF	ON
15). FLAMMABLE VAPORS DETECTED	ON	OFF	OFF	OFF	OFF	ON

16

Diagnostic Code Map

- 15 error codes
- 11 of 15 are self diagnosing
- You will need to work on
 - (3) Pressure Switch stuck closed
 - (4) Pressure Switch stuck open
 - (6) Max Ignition Attempts
 - (10) Unsupervised Flame

					A	B	C
1). OPEN GROUND	ON	OFF	OFF	ON	OFF	OFF	OFF
2). BAD GROUND / MISWIRED	ON	OFF	ON	ON	ON	ON	OFF
3). PRESSURE SWITCH STUCK CLOSED	ON	OFF	ON	OFF	OFF	OFF	OFF
4). PRESSURE SWITCH STUCK OPEN	ON	OFF	ON	OFF	OFF	ON	ON
5). OPEN IGNITOR / TRIAC FAULT	ON	OFF	ON	OFF	ON	ON	ON
6). RETRY / RECYCLE COUNT LIMIT	ON	OFF	OFF	ON	ON	ON	OFF
7). GAS VALVE CIRCUIT ERROR	ON	OFF	OFF	OFF	ON	ON	ON
8). DATA RETENTION ERROR	ON	OFF	ON	ON	ON	ON	OFF
9). INTERNAL FAULT / POWER UP	ON	ON	ON	ON	ON	ON	ON
10). UNSUPERVISED FLAME	ON	OFF	OFF	OFF	ON	OFF	OFF
11). OPEN ECO	ON	OFF	OFF	ON	ON	ON	ON
12). TEMP. ADJ. BUTTON STUCK CLOSED	ON	OFF	ON	ON	OFF	OFF	OFF
13). OPEN / SHORTED THERMISTOR	ON	OFF	ON	ON	OFF	ON	ON
14). OPEN / SHORTED FV SENSOR	ON	OFF	OFF	ON	OFF	ON	ON
15). FLAMMABLE VAPORS DETECTED	ON	OFF	OFF	OFF	OFF	ON	ON

17

Error 1 – Open Ground

ERROR 1

Indicates: An open earth ground circuit to the ignition system.

Check, Repair, or Replace

- 1). Check that the earth ground conductor is properly connected at the fuse box or breaker panel and the water heater.
- 2). Check that the grounding conductors on the water heater are properly connected and secure.

```

    graph TD
        A{IS LINE POLARITY OK?} -- NO --> B[DISPLAY ERROR CODE 7]
        A -- YES --> C{IS GROUND OK?}
        C -- NO --> D[DISPLAY ERROR CODE 1]
        C -- YES --> E[ ]
    
```

18

Error 2 – Polarity Reversed

ERROR 2

Indicates: The self diagnostic test detected a wiring error or a high resistance to earth ground.

Check, Repair, or Replace

- 1) Check for proper connection of the line neutral and line hot wires.
- 2) Check that the appliance is securely connected to earth ground.

```

graph TD
    Q1{IS LINE POLARITY OK?} -- NO --> E2[DISPLAY ERROR CODE 2]
    E2 --> L1[TO LOCKOUT "TIMED RESET"]
    Q1 -- YES --> Q2{IS GROUND OK?}
    Q2 -- NO --> E1[DISPLAY ERROR CODE 1]
    E1 --> L2[TO LOCKOUT "OPEN GROUND"]
    Q2 -- YES --> Exit(( ))
    
```

19

Error 3 – Pressure Switch will not Open (normally open switch)

ERROR 3

Indicates: The pressure switch remained closed longer than 5 seconds after the call for heat began.

Check, Repair, or Replace

- 1) The pressure switch wiring is incorrect.
- 2) The pressure switch is defective and must be replaced.

Verify continuity of pressure switch.
If continuity present, then replace switch.
May also be caused by a jumpered switch

```

graph TD
    Q1{IS PRESSURE SWITCH PROVEN OPEN WITHIN 5 SECONDS?} -- NO --> E3[WAIT FOR PRESSURE SWITCH TO OPEN DISPLAY ERROR NUMBER 3]
    E3 --> Q1
    Q1 -- YES --> B1[COMBUSTION BLOWER ON]
    B1 --> Q2{IS PRESSURE SWITCH PROVEN CLOSED WITHIN 5 SECONDS?}
    Q2 -- NO --> E4[WAIT FOR PRESSURE SWITCH TO CLOSE DISPLAY ERROR NUMBER 4]
    E4 --> Q2
    Q2 -- YES --> Exit(( ))
    
```

20

Error 4 – Pressure Switch will not Close (inducer will close switch)

ERROR 4

Indicates: The pressure switch remained open longer than 5 seconds after the combustion blower was energized.

Check, Repair, or Replace

- 1) The pressure switch wiring is incorrect.
- 2) The pressure switch tubing is not connected correctly.
- 3) Obstructions or restrictions in the water heater air intake or exhaust flue.

May be caused by a blocked or restricted vent; pinched rubber hose to the pressure switch or a disconnected pressure switch.

1. Verify plastic tubing to pressure switch
2. Recycle heater
3. If heater starts, then the venting is the problem
4. If the heater goes back into error code, replace blower and pressure switch

21

Error 5 – Hot Surface Ignitor Circuit Error (Silicon Nitride Ignitor)

ERROR 5

Indicates: The self diagnostic test has detected an error in the Hot Surface Ignitor circuit.

Check, Repair, or Replace

- Unplug water heater from wall.
- Disconnect the ignitor connector and measure the ignitor resistance with an accurate ohmmeter between pins 1 and 2. Resistance should be between 11.5 and 18.6 ohms. If the reading is incorrect, replace the Hot Surface Ignitor.
- If the above checks are good, replace the INTELLI-VENT™ control.

WARNING

SHOCK HAZARD – COULD RESULT IN PERSONAL INJURY AND/OR DEATH

- Disconnect electrical power before servicing this appliance.
- Service should only be performed by a trained and experienced technician.

22

Error 6 – Max Ignition Attempts (3 strikes and your out)

ERROR 6

Indicates: The maximum number of ignition retries or recycles has been reached and the system is in lockout.

Check, Repair, or Replace

- Check if the gas supply is off or too low to operate.
- Check that the flame sense rod to see that it is located properly and free from contamination. Reposition the flame sense rod or lightly clean with an abrasive cloth.
- The Hot Surface Ignitor may not be positioned correctly. Reposition as necessary.
- The Hot Surface Ignitor and Flame Sense Rod wired correctly and in good working condition. Repair as required.
- Low voltage to the water heater. Check and repair.

A broken or damaged hot surface ignitor will present it's own unique fault code.

23

Error 7 – Gas Valve Circuit Problem

ERROR 7

Indicates: The self-diagnostic test found a problem with the gas valve driver circuit.

Check, Repair, or Replace

- Cycle power to the water heater off for 10 seconds and then back on.
- If the above step did not clear the error, the INTELLI-VENT™ control must be replaced.

No counter test is available.

Self diagnostic test takes precedent.

24

Error 8 – Gas Valve Internal Problem

ERROR 8



Indicates: The self-diagnostic test has detected a problem with the internal microcomputer.

Check, Repair, or Replace

- 1). Cycle the external power off for 10 seconds and then back on.
- 2). If the above step does not clear the error, the INTELLI-VENT™ control must be replaced.

No counter test is available.

Self diagnostic test takes precedent.



25

Error 9 – Failed Self Diagnostic Check

ERROR 9



Indicates: The self-diagnostic test has detected a problem with the internal circuit.

Check, Repair, or Replace

- 1). Cycle the external power off for 10 seconds and then back on.
- 2). If the above step does not clear the error, the INTELLI-VENT™ control must be replaced.

No counter test is available.

Self diagnostic test takes precedent.



26

Error 10 – Unsupervised Flame

ERROR 10



Indicates: Flame signal sensed out of proper sequence.

Check, Repair, or Replace

- 1). Replace the INTELLI-VENT™ control.

Recycle heater and observe combustion chamber for premature flame or flame once the thermostat is satisfied.



27

Error 11 – ECO is tripped

ERROR 11

Indicates: The high temperature thermal cutoff is open.

Check, Repair, or Replace

- 1). Replace the INTELLI-VENT™ control.

Automatic High Temperature Cutoff
Single-Use Type, 195°F (90°C)

28

Error 12 – Temp Adjustment buttons stuck closed

ERROR 12

Indicates: The self-diagnostic test has detected one of the temperature adjust buttons stuck closed.

Check, Repair, or Replace

- 1). Make sure that there are no objects leaning against the front of the control.
- 2). Lightly press and release each of the buttons once.
- 3). If the above actions do not clear the error, the control will continue to regulate water temperature at the last setting, but you not be able to change settings unless you replace the INTELLI-VENT™ control.

No counter test is available.

Self diagnostic test takes precedent.

29

Error 13 – Water Temp Thermistor Problem

ERROR 13

Indicates: The self-diagnostic test has detected that the water temperature sensor is either open or short circuited.

Check, Repair, or Replace

- 1). Check that all wiring is correct and that there are no open or shorted circuits.
- 2). If no wiring problems are found the INTELLI-VENT™ control must be replaced.

No counter test is available.

Self diagnostic test takes precedent.

```

    graph TD
      Start[START] --> Question{IS THERMISTOR WITHIN LIMITS?}
      Question -- YES --> Return[RETURN]
      Question -- NO --> Display[DISPLAY ERROR CODE 13]
      Display --> Action[TURN OFF IGNITOR  
CLOSE GAS VALVE]
      Action --> Lockout[TO LOCKOUT  
BAD THERMISTOR]
    
```

30

Error 14 – FV Sensor Wiring Problem



ERROR 14



Indicates: The self-diagnostic test found a problem with the Flammable Vapor Sensor.

Check, Repair, or Replace

- 1). Check that all wiring is correct and that there are no open or shorted circuits.
- 2). If no wiring problems are found, the Flammable Vapor Sensor must be replaced.





1. Check all FV sensor wiring harness connections; and the connections to the back of the sensor.
2. Cycle power to the water heater off for 10 seconds and then back on.
3. If no wiring problems are found, the Flammable Vapor Sensor must be checked.
 - a. Disconnect the FV sensor Molex and measure the resistance of the sensor between the two black wires 1 and 2. If the resistance is less than 9k OHMS or greater than 45k OHMS, then replace the sensor.
 - b. If the FV sensor is between 9K and 45K and the code will not clear, replace the INTELLI-VENT control.

31

Error 15 – FV Sensor Detected Flammable Vapors

ERROR 15



Indicates: The control detected the presence of flammable vapors near the appliance and entered lockout.

Check, Repair, or Replace



1. Verify FV sensor is less than 45k Ohms between the two black wires #2 and #3
2. Replace sensor if greater than 45k Ohms
3. Apply reset code to valve



32
