

INTRODUCTION

The **Rain-Clik™** you have just purchased provides a new level of performance, water savings, and installation convenience never seen before in an economical rain sensor package.

The Rain-Clik acts as a switch to break the circuit to the solenoid valves of the irrigation system when it has rained. This allows the timer to advance as scheduled, but keeps the valves from opening the water flow. Once the Rain-Clik has dried sufficiently, the switch closes again to allow for normal operation. The Rain-Clik is supplied with 25 feet of wiring for installation on your controller.

Unlike other rain sensors, you do not need to figure out the setting for rainfall shutoff. The Rain-Clik is self-adjusting. Your sprinkler system will be shut down within the first few minutes of any rainfall, yet the total amount of rain received is registered inside the unit and determines how long your system will stay off. The **Rain/Freeze-Clik** includes a freeze sensor that is designed to keep the system from operating at or below 37°F (3°C). At temperatures above 37°F, it will close the circuit for normal sprinkler operation. The freeze sensor prevents ice on landscapes, roadways and walkways.

MOUNTING

Standard Mount:

Using the screws provided within the package, mount the Rain-Clik on any surface where it will be exposed to unobstructed rainfall, but not in the path of sprinkler spray. The switch housing portion must be upright (as pictured), but the swivel-bracket can be moved for mounting on any angles surface. Loosen the locknut and screw before swiveling the bracket, and then re-tighten.

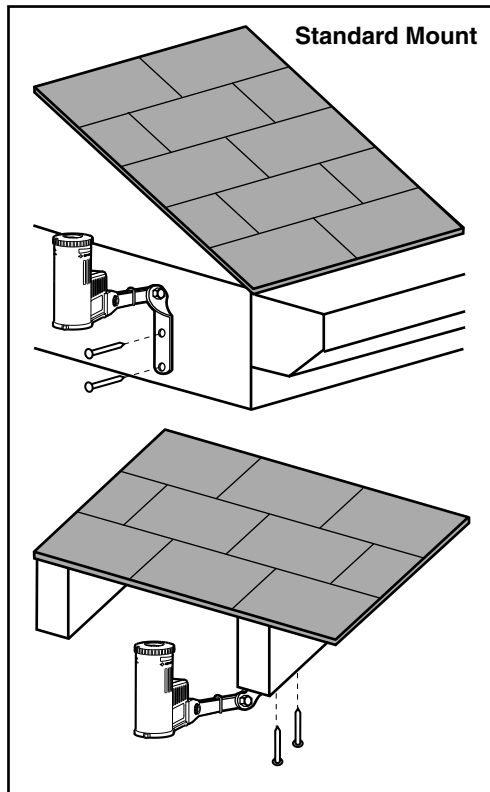

Gutter Mounting (SGM Sold Separately):

The gutter mount can be purchased as an optional accessory for your Rain-Clik (order p/n SGM). The SGM allows the Rain-Clik to be mounted directly to the side of a gutter. To install your Rain-Clik on a gutter, remove the screw, nut, and standard metal extension arm supplied with the Rain-Clik, and reinstall the screw and gutter mount. Position the gutter mount on the edge of the gutter and twist the thumbscrew to secure it in place.

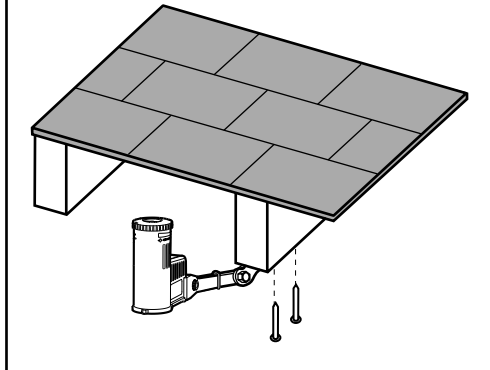

Helpful Hints for Mounting:

A. When looking for a suitable location such as the side of a building or post, the closer the Rain-Clik is to the controller, the shorter the wire run will be. This will also minimize the chance for wire breaks.

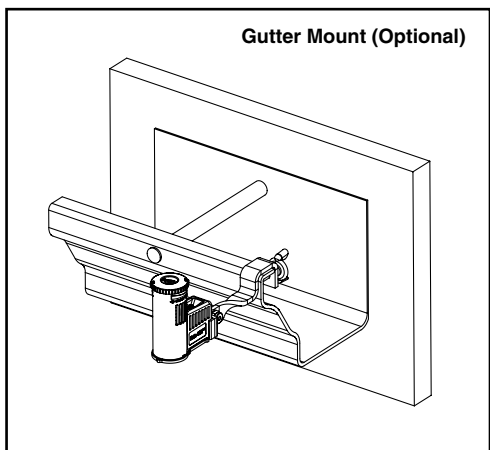

- B. Correct placement of the Rain/Freeze-Clik model is important for accurate temperature sensing. The best location would be out of direct sunlight (Fig A).
- C. As described in the "Operation" section of this manual, "reset rate" refers to the amount of time it takes the Rain-Clik to dry out sufficiently for the sprinkler system to be allowed to come back on. The mounting location will affect this rate and should be taken into consideration should extreme conditions exist. For example, mounting the Rain-Clik on a very sunny, southern end of a building may cause the Rain-Clik to dry out sooner than desired. Similarly, mounting on the northern end of a building with constant shade may keep the Rain-Clik from drying soon enough.

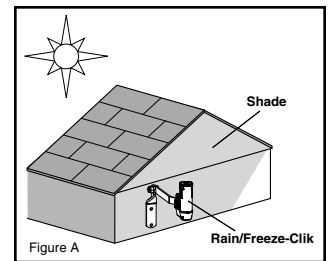

Once the Rain-Clik is mounted, run the wire to the controller, and fasten it every few feet with wire clips or staples for best results. Be careful not to cut through the wire insulation with fastening hardware or chaff the insulation when routing wire through or around metal materials (i.e. gutter, siding, etc.). If an extension to the wire provided is needed, use the following table to determine the minimum wire gauge needed:

If the extension needed is:	25-50 ft.	50-100 ft.	100 ft or more
use:	20 AWG	18 AWG	16 AWG

WIRING TO YOUR IRRIGATION SYSTEM

Important: The **Rain-Clik** is sold and designed for hook up to 24 Volt irrigation controllers only.

WARNING! This unit is designed to be installed in conjunction with 24VAC circuits only. Do not use with 110 or 220VAC circuits.

Wiring to the Hunter SRC

The Rain-Clik connects directly to the SRC. This allows you to easily override the sensor by using the RUN (BYPASS SENSOR) position on the dial.

1. Route the wires from the Rain-Clik up through the same opening used for valve wiring.
2. Connect one wire to the RS terminal and other to the C terminal (See Figure 1).
3. Connect the valve common to the RS terminal.

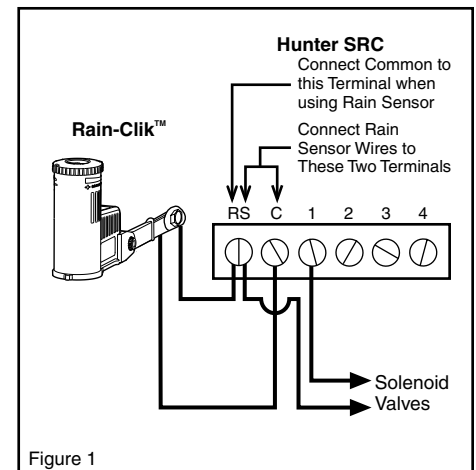

Wiring to the Hunter ICC, Pro-C, or EC Controllers

The Rain-Clik connects directly to the ICC or Pro-C. This allows you to easily override the sensor by using the Sensor switch on the front panel.

1. Remove the jumper from the two "SEN" terminals.
2. Route the wires from the rain sensor up through the same conduit opening used for valve wiring.
3. Connect one wire to the terminal labeled "SEN" and the other wire to the other "SEN" terminal (See Figure 2).

Other Controllers

The two most common situations are shown below.

A. 24 Volt Solenoid Valves Only (No booster pump) (See Figure 3).

With the two wires from the Rain-Clik at the controller, locate the "common ground" wire of the solenoid valves. If it is connected to the common terminal on the controller, disconnect it. Attach one wire of the Rain-Clik to the "common" terminal (usually marked "C") on the controller. Attach the other wire of the Rain-Clik to the common wire leading to the valves. **Note:** The common wire to the valves does **not** have to be interrupted at the controller. The Rain-Clik may be wired anywhere along the common wire line.

B. 24 Volt Solenoid Valves with Booster Pump (See Figure 4).

Locate the common wire to the solenoid valves and the common wire leading to the coil of the relay that starts the pump. If these two wires are connected to the "common" terminal on the controller, disconnect both of them.

Twist together these two wires along with one wire from the Rain-Clik, and secure with a wire nut. Attach the other wire of the Rain-Clik to the "common" terminal on the controller. *Note: The pump circuit output must be 24 Volts in this situation. Do not proceed if 110V.*

Operation Check to Verify Correct Wiring

Turn on one zone of the irrigation system that is visible while you are in reach of the Rain-Clik. Manually depress the spindle at the top of the Rain-Clik until you hear the switch "click" off. The sprinkler zone should stop instantaneously. If it does not, check wiring for correctness. It is not necessary to "wet" test the Rain-Clik, although it will test the operation fine, if desired. (See Figure 5)

ADJUSTMENTS AND OPERATION

The Rain-Clik can keep the irrigation system from starting or continuing after rainfall.

The time that it takes the Rain-Clik to reset for normal sprinkler operation after the rain has stopped is determined by weather conditions (wind, sunlight, humidity, etc.). These conditions will determine how fast the hygroscopic discs dry out, and since the turf is also experiencing the same conditions, their respective drying rates will roughly parallel each other. So when the turf needs more water, the Rain-Clik is already reset to allow the sprinkler system to go at the next scheduled cycle.

There is an adjustment capability on the Rain-Clik that will slow down the reset rate. By closing the "vent" (see Figure 6) to completely or partially cover the ventilation slots, the hygroscopic discs will dry out more slowly. This adjustment can compensate for an "overly sunny" installation location, or peculiar soil conditions. Experience will best determine the ideal vent setting.

The Rain-Clik utilizes a single disc technology to turn off your sprinkler system within the first five minutes of the rain falling. For light showers and amounts of rain less than 1/8", the single disc will shut off the system for 30 minutes to 4 hours, depending on weather

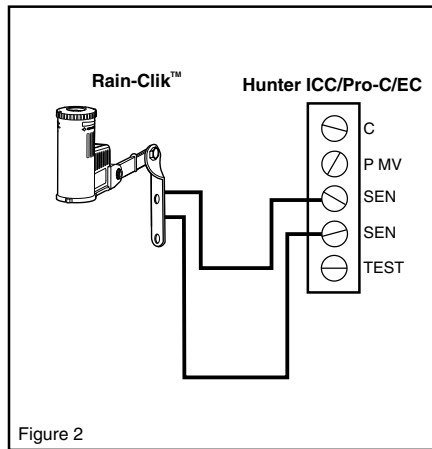

Figure 2

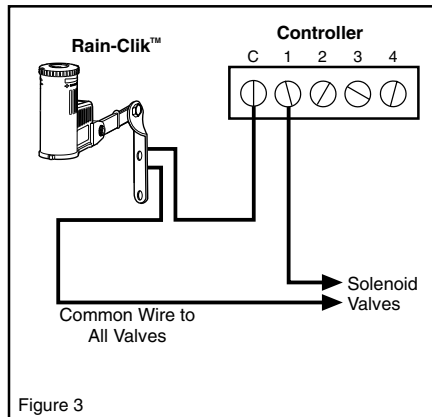

Figure 3

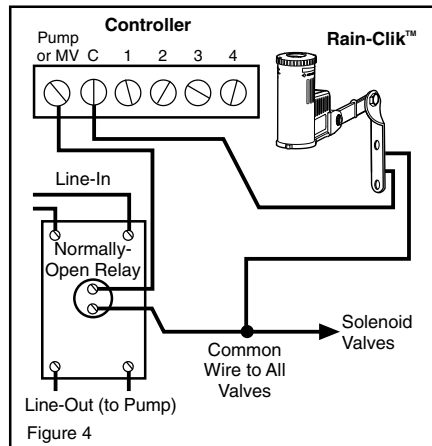

Figure 4

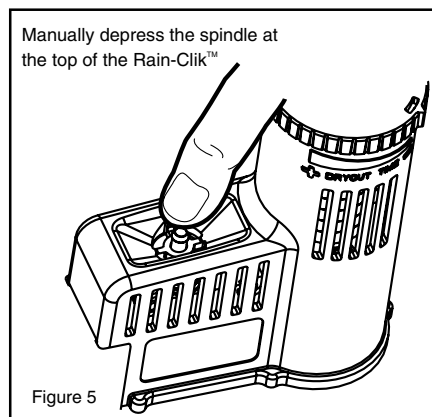

Figure 5

conditions. Adjusting the vent cap will not have an effect on the dryout time of the single disc. For heavier rain showers in excess of 1/8", the disc stack under the vent cap will hold the system off for an appropriate amount of time. The disc stack dryout time is what the vent cap adjustment controls.

BYPASSING THE SENSOR

The Hunter ICC, Pro-C, and SRC controllers are equipped with a built-in bypass that allows you to override an active sensor. For controllers not equipped with this feature, should you desire to bypass the operation of the Rain-Clik for any reason (i.e., turn on your system even though the Rain-Clik has shut "off" due to rainfall), there is a simple way to do this—add our Bypass Switch Box. This mounts on or next to the controller, and by simply moving the switch, the Rain-Clik is bypassed.

Note: Using the "manual" switch on non-Hunter controllers typically will not bypass the sensor.

MAINTENANCE

There is no required maintenance for the unit. The Rain-Clik does not have to be removed or covered for "winterizing" purposes.

Troubleshooting

Follow these simple checks first before assuming the unit is bad and replacing it.

System will not come on at all:

- First, check to see that the Rain-Clik discs are dry and the switch "clicks" on and off freely by pressing the top of the spindle.
- Next, look for breaks in the wire leading to the Rain-Clik and check all wire junctions.
- Verify temperature is above 37° F (for Rain/Freeze-Clik model).

System will not shut off even after heavy rainfall:

- Check wiring for correctness (see "Operation Check to Verify Correct Wiring").
- Is the rainfall actually hitting the Rain-Clik? Check for obstructions to rainfall such as overhangs, trees or walls.

Manufactured under U.S. Patent Pending

All Rain-Clik™ models are listed by Underwriters Laboratories, Inc. (UL). Samples of these devices have been evaluated by UL and meet the applicable UL standards for safety.

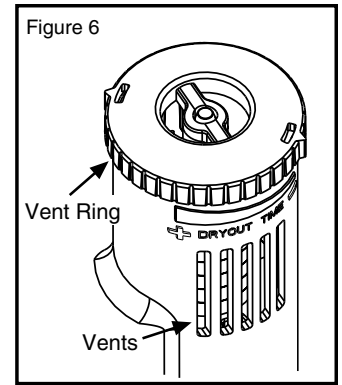

Figure 6