

CAUTION...Read this entire instruction manual carefully BEFORE attempting to install or operate this time switch. Failure to comply with instructions could result in personal injury and/or property damage.

INTRODUCTION

This time switch is designed to control lighting, HVAC, refrigeration, and other energy consuming loads as well as security and convenience systems. It is capable of reducing energy consumption by providing accurate, independent scheduling, cycling and defrost control. This time switch is ideal for small or medium size buildings such as schools, churches, restaurants, apartment complexes, fast food restaurants and other applications where accurate, full-year control of energy is desired.

THE ET7115C FEATURES ARE:

- Independent to-the-minute scheduling, cycling and defrost control for one circuit.
- A total of 36 set points, assignable in ANY COMBINATION to ON times, OFF times, daylight saving time dates and holidays.
- Copy feature copies all programmed times, from one day to any other day(s), effectively increasing number of scheduling times.
- Solid state memory protection circuit maintains all program date and time-of-day for 24 hours minimum without the need for batteries and associated battery maintenance.
- Single pole double throw (SPDT) isolated contacts.
- Full year control with automatic daylight saving time and leap year adjustment.
- Automatic day of week correction.
- Programming for an 8th day (A1) in addition to the normal 7 day week. (For holidays)
- Holidays programmable one year in advance, by month and date assignment. Can be assigned to the alternate day (A1) or any of the 7 week days.
- Load status indicator.
- Manual on/off override.
- Easy to program - uses the same programming steps, for set points, as the Intermatic ET700 series time switches.
- Automatic review feature for easy review of data points and calendar information.
- Continual display of current day and time.
- .14" LED display prevents washout and provides easy programming even in poorly lit area.
- Large, well defined keypad with tactile feel.
- Rugged steel enclosure with lockable hasp. Optional flushmount, plastic, or steel raintight (NEMA 3) or 2 in 1 enclosures available.

TABLE OF CONTENTS

	PAGE
SPECIFICATIONS	1
INTRODUCTION	2
FEATURES	2
INSTALLATION	3-4
CONTROLS AND OPERATING INFORMATION	4-5
PROGRAMMING	6-7
SAMPLE PROGRAM	8
SAMPLE WIRING DIAGRAMS	9
TROUBLE SHOOTING	10
BLANK SCHEDULES	11-12
HOLIDAY SCHEDULE	13
SHORT FORM PROGRAMMING	14
GLOSSARY	15
WARRANTY	16

SPECIFICATIONS

ELECTRICAL

Input Power:

CAUTION: Refer to Sample Wiring Diagram section for correct timer input power connections. Incorrect wiring could damage the time switch.

Power Consumption:

4.0 Watts Maximum with both output relays energized.

Timing Accuracy:

Time of day is as accurate as the line frequency and can be synchronized to the second.

Switch Configuration:

Single pole double throw (SPDT) isolated contacts.

Switch Rating:

Refer to label on inside of case cover.

Wiring Terminals:

Accommodates #18 to #14 AWG wire.

Approvals:

UL Listed (CSA approval pending)

Program and Time of Day Protection:

Internal solid state circuit maintains program and correct time of day within 0.01% (0.002 typical) accuracy for 24 hours (48 hours typical) minimum. This circuit will fully charge within 5 minutes after input power is applied to the time switch. **THIS SOLID STATE CIRCUIT DOES NOT REQUIRE A BATTERY.** For additional operating characteristics of the solid state memory backup circuit see **CONTROLS AND OPERATING INFORMATION.**

ENVIRONMENTAL

Operating Temperature Range:

-40 degrees F (-40 degrees C) to 122 degrees F (50 degrees C). Hold-up time for solid state program protection circuit may be less than specified outside of 32 degrees F (0 degrees C) to 104 degrees F (40 degrees C).

Operating Humidity:

0-95% noncondensing

PHYSICAL

Case:

Drawn steel; 7 $\frac{1}{4}$ " (19.7 cm) high, 5" (12.7 cm) wide, 3" (7.6 cm) deep; gray finish w/lockable spring hasp.

Case Knockouts:

Combination 1/2"-3/4" (one on back and each side, two on bottom)

Shipping Weight:

2.9 lbs (1.32 kg)

INSTALLATION

REMOVE DEAD FRONT (fig. 1): An electrical insulator called a "dead front" is installed to prevent accidental contact with the electrical connections, and a possible shock hazard. Lift the left side of the dead front off of the retaining post and pivot it up and to the right to expose the terminal strip. Be sure to replace the dead front after making all wiring connections.

MOUNT CASE: Using the mounting holes provided, mount case, eye level if possible, using anchors if necessary. Note: Allow sufficient room to left of case for the door to open.

MAKE LINE WIRE CONNECTIONS: (See sample wiring diagrams) **CAUTION:** Turn power off at the panel board. You may have to remove two fuses or switch two breakers to the OFF position. If the panel board is out of sight, tag it to prevent power from inadvertently being turned on. Connect the line wires from the panel board to the timer input power terminals. For time switches requiring 120 volt power, either the hot or neutral may be connected to either terminal. **CAUTION:** Failure to follow the correct input power connections for the available power can cause damage to the time switch. For a 120 volt supply make sure the hot and neutral wires are identified by the appropriate color coding or by another code accepted and permanent means. Securely connect the ground lead to the ground connection in the case. The ground screw is identified by the green color.

MAKE LOAD WIRE CONNECTIONS: (See sample wiring diagrams) **CAUTION; TURN POWER OFF** to the load to prevent inadvertent load actuation. Identify and label all wires from the load or load control devices to ensure that load connections are as desired. Connect load wires or load control device wires to the appropriate terminals on the terminal strip. See contact configuration shown on door label. Output contacts, are isolated contacts. This means that the contacts are not automatically powered when power is connected to the timer input power terminals. Power to the contacts can either be paralleled off of the timer input power, thru the load, or supplied by a separate power source. Note that the normally closed contacts can be used for switching set-back temperature controls or to provide selected load shedding if required.

Load control devices; relays, contactors, motor starters, etc., are required if the load exceeds the voltage and or current ratings of the time switch contacts. As noted previously, the contacts are isolated contacts and therefore must be supplied power by either providing a separate power source or by paralleling from the timer input power, through the load. If the time switch power input is 120 volt and power is being paralleled from the timer input power terminals, be sure the time switch contacts are breaking the hot side of the line. This is done by connecting the hot wire to the common terminal and the neutral wire to one side of the load. The other side of the load is then connected to either the normally open or normally closed contacts of the time switch.

CAUTION: For critical loads, appropriate safety overrides should be installed in conjunction with the time switch contacts; high temperature thermal switch overrides for refrigeration control in a grocery store for example.

When switching 24 volt control devices do not use excessive wire lengths because a large voltage drop across the wire may prevent sufficient operating voltage from being applied to the control relay. If in doubt, connect and test the relay, that is to be installed furthest from the time switch, using the required length of wire and wire size planned.

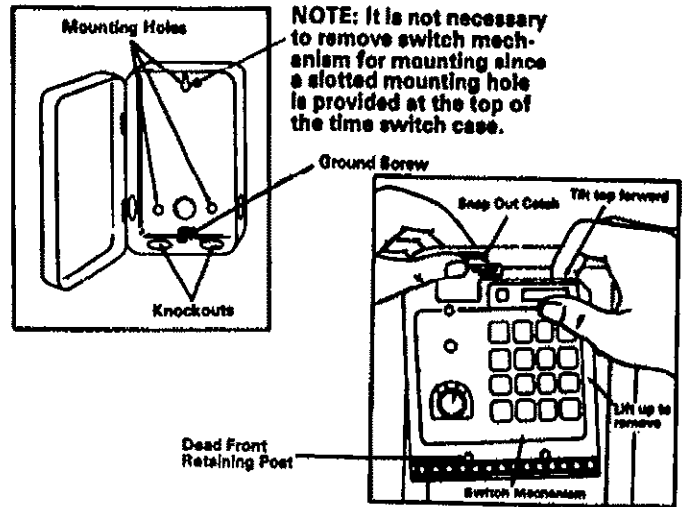

Fig. 1

The approximate resistance of COPPER wire in ohms per 1000 feet is:

14 AWG 2.52 ohms/1000 feet 20 AWG 10.15 ohms/1000 feet
16 AWG 4.02 ohms/1000 feet 22 AWG 16.14 ohms/1000 feet
18 AWG 6.38 ohms/1000 feet 24 AWG 25.67 ohms/1000 feet

As an example, a run of 600 feet is required, 18 AWG copper wire is to be used, and the relay, using a 24 volt coil, draws 350 milliamperes of current. Total wire length, including return run, is 1200 feet.

- The wire resistance equals the total number of feet times the resistance per foot.
or 1200 ft. x 6.38 ohms/1000 ft. = 7.66 ohms.
- The voltage drop equals the resistance times the current.
or 7.66 ohms x .35 amps = 2.68 volts.

Most relays are designed to operate at a minimum of 85% of their nominal voltage or 15% less than nominal. For a 24 volt relay this means it would operate at a minimum of 3.6 volts less than nominal. Based on this, the 2.68 volts drop across the 1200 feet of wire would not be excessive.

Insert stripped ends of COPPER wires (18 to 14 gauge, solid or stranded) under the pressure plate and securely tighten the terminal screws. **DO NOT USE ALUMINUM WIRING.** Be sure insulation clears the pressure plate.

Surge suppressors (metal oxide varistors or MOV's) may be installed across the normally open and normally closed contacts for inductive load switching. Use INTERMATIC part number 176ET8A (General Electric #V472A1) for 24 volt loads, 176ET9A (V150LA10A) for 120 volt loads, 176ET10A (V300LA4) for 240 volt loads or 176ET22A (V320LA20A) for 277 volt loads. Although unlikely to be required, additional protection against electrical "noise" interfering with the operation of the microprocessor may be achieved by installing surge suppressors across the contacts of the externally controlled switching devices such as relays, contactors or motor starters. The proper surge suppressors to use will depend on the load being controlled. Consult manufacturer of transient protection devices or the manufacturer of the controlled switching device for the recommended surge suppressor to use.

CHECK WIRING: Make sure all grounding leads are securely connected to a good earth ground. (See fig. 1) Check all wiring, then replace the dead front by pivoting it down over the locating post provided.

TEST WIRING AND TIME SWITCH FUNCTION: Apply line power. Within 60 seconds the display should indicate Day 1 (Sunday) 10:00 AM. If the display is lit but indicates something other than Sunday 10:00 AM, or if the display is not lit after 60 seconds, press the recessed RESET switch and hold it for 5-10 seconds. The display should now indicate Sunday 10:00 AM.

If the display does not light up within 60 seconds, even after pressing the RESET switch, move the mode selector to the MAN position then press the ON/COPY keypad. Note that this may cause the load to operate. If this does not cause the load indicator to light, recheck time switch power connections to make sure time switch is actually receiving line power.

CONTROLS AND OPERATING INFORMATION

(See Fig. #2)

LOAD INDICATORS: The LED indicator monitors the status of the load relay. When the indicator is LIT, the NORMALLY OPEN (NO) contacts are CLOSED. Likewise, when the indicator is NOT LIT, the NORMALLY OPEN contacts are OPEN.

CAUTION: A load may be on or off when the indicator is lit, depending on whether the load is wired to the normally open or normally closed contacts.

When performing load maintenance DO NOT use the manual override as a means of turning off power to the loads and do not use the load indicator to determine if there is power to the loads.

ALWAYS TURN POWER TO THE LOADS OFF AT THE PANEL BOARD WHEN PERFORMING LOAD MAINTENANCE.

MODE SELECTOR: This (5) position selector switch is used to select one of five modes; MAN, AUTO, REVIEW, SET or CLNDR/HLDY SET.

● **MAN (Manual):** Placing the mode selector in the MAN mode allows automatic load control to be overridden. The load can be switched on or off in the manual mode by pressing the ON/COPY or OFF keypads. The load will remain on or off, as indicated by the load indicator until the automatic (AUTO) mode is once again selected. When power is restored after a power failure and the mode selector is in MAN, the load will remain off.

To resume automatic load switching, return the mode selector to the AUTO mode. When the mode selector is returned to the AUTO mode the load will, within 2 minutes, assume the state dictated by the most recent preceding set point. If no set points exist between midnight and the current time of day, the load will remain in the same state as when the selector was moved to AUTO and remain in this state until the time of day for which a set point is programmed for the opposite state.

● **AUTO:** This position of the selector provides for automatic program control of the load.

Note that the load can be temporarily switched on or off in the AUTO mode by pressing the ON/COPY or OFF keypad. The load will remain in the selected on or off state until the next, programmed, opposite state. If the mode selector is moved to another position during this time, then returned to the AUTO mode, the loads will return to the current programmed on or off state. The system switches the load, at the START of the minute. Because of this, if you return to AUTO and a load, that is programmed to be on, has been temporarily switched off; that load may not switch on until after the start of the next minute.

● **REVIEW:** This position of the selector provides for review of all programmed on and off times and, if required, omitting any on and off times. The REVIEW position is used for reviewing and omitting calendar information as well.

● **SET:** This is the position the mode selector must be in to program the current day, time of day and ON/OFF set points.

**Note that the ET7115C uses the exact same procedure for setting data in the SET mode as does the Intermatic ET700 series time switches.

The day and time of day as well as all programmed on and off times are programmed using the following sequence.

- 1-Press a day keypad 1=Sunday, 2=Monday, etc. or A1
The alternate day (A1) is an extra "8th" day and can be used to program holidays, or other selected days, for a different schedule than any of the 7 days of the week.
- 2-Press the numbered keypads, 1 thru 0, to select the time, hours first, then minutes. The clock is a 12 hour repeating clock and a leading zero is not required. For example 6:00 A.M. is set by pressing 6 0 0.
- 3-Press AM or PM (12:00 PM is noon)
- 4-Press the ON/COPY, OFF or CLK/HLDY keypads respectively to program an on time, off time or to set the time of day.

CAUTION: The load may be programmed for short on and off times (1 minute) to provide for load cycling. When doing so it is important to follow manufacturers guidelines for cycling equipment. Failure to adhere to these guidelines can affect the life and warranty of that equipment. If in doubt, consult the equipment manufacturer for recommended duty cycling rates.

● **CLNDR/HLDY SET (Calendar/Holiday):** This position of the mode selector is used to program the following calendar information to provide for a full year control.

1-Month and Date

2-Year

3-Daylight saving time adjustment for Spring and Fall (2:00 A.M. for the days programmed).

4-Holidays or special days, programmed by Month and Date, and assigned to any of the eight available days (Sunday thru Saturday or A1).

For convenience in programming, the daylight saving time dates thru the year 2001 are shown in the programming section of this manual.

RESET and MEMORY CLEAR SWITCHES (MC) and CLEAR (C) KEYPAD: Pressing the RESET switch causes the micro-processor to reinitiate. This also resets the time to 10:00 A.M. RESET DOES NOT clear any of the programmed on/off times or any programmed calendar data.

Pressing the MEMORY CLEAR (MC) switch alone has no effect on the programmed data. If the CLEAR (C) keypad is pressed while MEMORY CLEAR (MC) is held depressed ALL PROGRAMMED ON/OFF TIMES AND CALENDAR DATA ARE ERASED from the memory. Display will blink until this process has been completed.

KEYBOARD: The keyboard is used to select and enter all calendar and on/off program times. All keypads have tactile feel when pressed.

- The number keypads 1 thru 0 are used to enter all calendar dates and set point times.
- The number keypads 1 thru 7 are also used to select the days SUNDAY thru SATURDAY. The number 8 keypad is used to select the alternate day (A1) and the number 0 keypad is used for programming daylight saving time (DST) adjustment.
- The AM and PM keypads are used to select "day or night" based on a 12 hour repeating clock. Note that 12:00 PM is 12:00 noon.
- The ON/COPY and OFF keypads are used to program ON and OFF set times and to temporarily switch the load on or off. The ON/COPY and OFF keypads can also be used to initiate manual or automatic set point review. Both methods of review are accomplished in the REVIEW mode. After a day to be reviewed has been selected, by pushing appropriate day keypad, the ON/COPY or OFF keypads are pressed, one at a time, for manual review of set points. Pressing both keypads simultaneously initiates the automatic set point review whereby all set points, for the selected day, are displayed in

chronological order beginning at 12:00 AM or midnight. Automatic or manual review may be terminated by exiting the review mode or by pressing any day keypad.

The ON/COPY keypad is also used to copy all set points from one day to another day(s).

- The CLK/HLDY keypad is used to set the time of day and to set or review all calendar data.
- The CLEAR (C) keypad is used to clear an error (EE:EE) indication, to clear the display if a mistake is made during data entry or to remove unwanted set point or calendar data during review. The CLEAR (C) keypad is also used in conjunction with the MEMORY CLEAR SWITCH (MC) to clear all set point and calendar data.

SOLID STATE MEMORY BACKUP OPERATING CHARACTERISTICS: When using the solid state memory backup the time switch has operating characteristics, as follows.

Immediately after restoration of power the output relay will be de-energized. Within one minute of restoration of line power, the time switch will "catch-up" with the existing programmed set point data. This means that the output will assume the state it would have been in, had there been no power failure. Any manual override, selected by use of the ON or OFF keypads, prior to the power outage will be overridden by the set points currently in effect. The only exception to this is if there are no set points programmed for that day for that circuit. If there are no set points programmed for that day, the output will return to the on or off state as selected by the ON or OFF keypad prior to the power outage.

It is recommended that override control be accomplished by use of a spring wound override. This will allow the time switch enclosure to be locked, to ensure that program control is made by authorized personnel only.

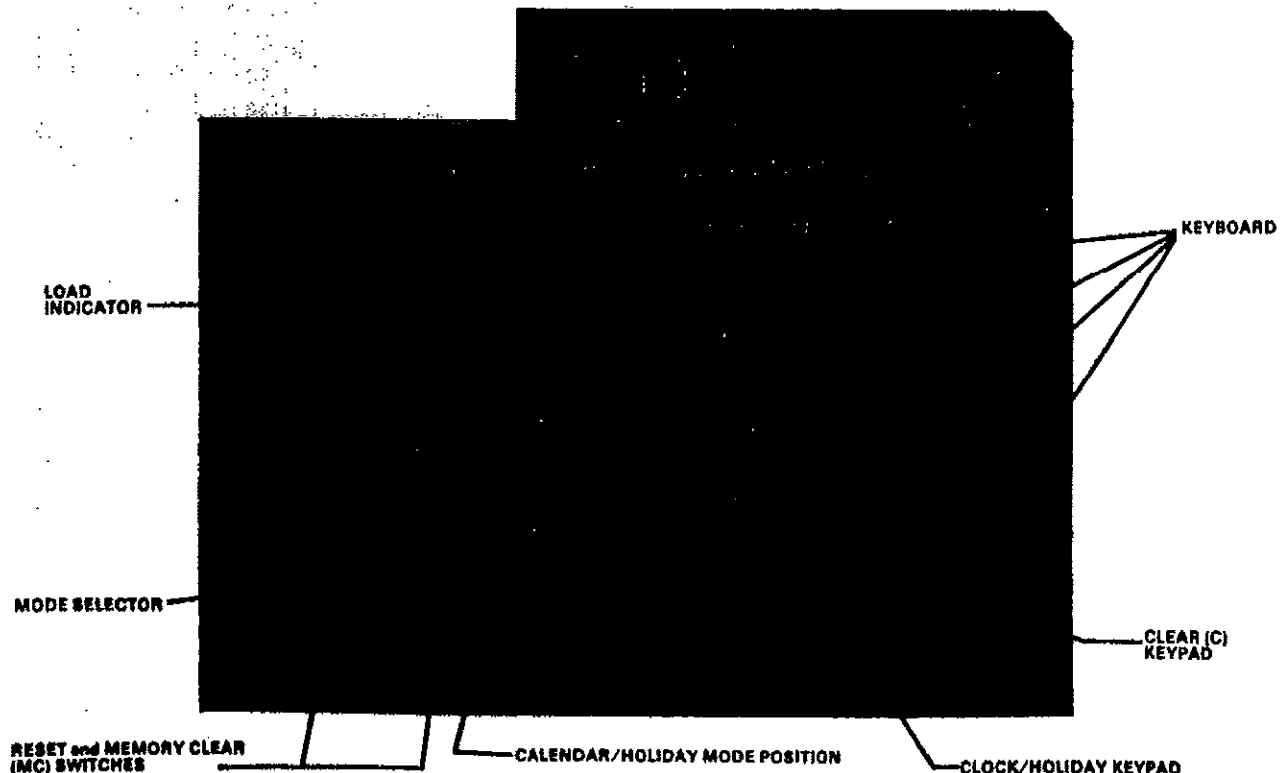

FIG. 2

PROGRAMMING

You may use the **SHORT FORM PROGRAMMING INSTRUCTIONS** which are located on the inside of the case cover and also in this instruction manual.

BEFORE BEGINNING TO PROGRAM, press and hold the **MEMORY CLEAR (MC)** switch then the **CLEAR (C)** keypad and hold both depressed simultaneously for 5 to 10 seconds. The display will blank momentarily when this is done.

This will insure that all data is removed from the memory and will reset the microprocessor. **DO NOT REPEAT THIS STEP AFTER PROGRAMMING HAS BEGUN** because the entire program will be lost.

The following sequence (#1, #2, etc.) is recommended for programming the time switch. Any desired sequence can be used, although calendar data must be entered prior to holiday and daylight saving time data.

● SET CALENDAR, HOLIDAY and DAYLIGHT SAVING TIME DATA

(Place mode selector in CLNDR/HLDY mode)

Existing data **CANNOT** be written over.

If month, date, holidays, and daylight saving time information has previously been entered, any portion can individually be cleared in the **REVIEW** mode. This can be done at any time. Re-enter only the new data.

NOTE: A maximum of 36 set points can be entered into the time switch memory. Each of the following count as one set point; an on time, an off time, each daylight saving time date, each copied day and each holiday. **ANY COMBINATION** of these data points can be programmed up to 36 set points. The display will prompt "FULL" if an attempt is made to add a setpoint after maximum number of setpoints have been programmed.

1—SET CALENDAR DATA (Place Mode Selector in CLNDR/HLDY MODE).

- The display should be prompting "-- --".
- Press the numbered keypads (1 thru 0) to select the current Month and Date. Note that a leading zero is required for the Date; example February 3rd is entered as 2 0 3. A leading zero is not required for the month, but may be entered.
- Press the CLK/HLDY keypad to enter the Month and Date.
- The display will prompt "Yr--" for a year entry.
- Press the numbered keypads to select the current Year.
- Enter only the last 2 digits; 8 7 for 1987.
- Press the CLK/HLDY keypad to enter the Year.
- The display now shows "-- -- --".

2—SET HOLIDAYS (Place mode selector in CLNDR/HLDY MODE).

- The display should be prompting "-- -- --".
- Press the day keypads (SUNday thru SATurday or Alternate Day A1) to select the day schedule that is to be run on the date desired.
- Next press the numbered keypads to select the Month and Date that the Holiday schedule is to occur. Note that a leading zero is required for the Date; example, March 8th is entered as 3 08.
- Next press the CLK/HLDY keypad to enter.
- The display will Prompt "X XX XX" showing holiday data entered.
- Repeat this procedure for as many days, in the coming year, as required.

3—SET DAYLIGHT SAVING TIME ADJUSTMENT -

Spring and Fall. (Place mode selector in CLNDR/HLDY MODE). REFER TO CHART, which follows, for DST dates.

- The display should now be prompting with last holiday entered or "-- -- --" if CLNDR/HLDY mode is selected.
- Press the O/DST keypad.
- The display will Prompt "O -- --".
- Press the numbered keypads to select the Month and Date for DST to begin. A leading zero is required for the Date; for example April 7th is entered as 4 0 7. This is the date, at 2:00 AM, that the clock will advance 1 hr.
- Press the CLK/HLDY keypad.
- The display shows "S X XX" showing the date entered and "S" for Spring.
- Press the O/DST keypad again.
- The display will prompt "O -- --".
- Press the numbered keypads to select the Month and Date for DST to end. The clock will fall back by 1 hr. at 2:00 AM on this date.
- Press the CLK/HLDY keypad.
- The display shows "F XX XX" showing the date entered and "F" for Fall.
- Note that either Spring or Fall can be entered first. The system automatically determines if the date is Spring or Fall by the following convention:
If the month entered is 1 (January) thru 6 (June) the date assigned is Spring.
If the month entered is 7 (July) thru 12 (December) the date assigned is Fall.

Both Spring and Fall dates must be entered for DST adjustment to function. BASED ON THE DST LAW EFFECTIVE FOR 1987 the following are the DST dates (the first Sunday of April and the last Sunday of October) for the coming years. The DST dates must be reentered each year.

YEAR	SPRING	FALL	YEAR	SPRING	FALL
1987	Apr 05	Oct 25	1994	Apr 03	Oct 30
1988	Apr 03	Oct 30	1995	Apr 02	Oct 29
1989	Apr 02	Oct 29	1996	Apr 07	Oct 27
1990	Apr 01	Oct 28	1997	Apr 06	Oct 26
1991	Apr 07	Oct 27	1998	Apr 05	Oct 25
1992	Apr 05	Oct 25	1999	Apr 04	Oct 31
1993	Apr 04	Oct 31	2000	Apr 02	Oct 29
			2001	Apr 01	Oct 28

● SET CLOCK AND SCHEDULE TIMES (Place mode selector in SET MODE).

1—SET CURRENT DAY OF WEEK AND TIME OF DAY

The display should be prompting "-- --:--".

Press a day keypad to select the current day; SUNDAY thru SATURDAY, then press the number keypads to select the HOUR and MINUTE, then press AM or PM (12:00 PM is noon).

The display should now be prompting with time of day and the number corresponding to the day of week selected. Press the CLK/HLDY keypad.

The display will prompt "-- --:--". The time of day is displayed only in AUTO mode.

Note: The calendar information, previously entered, is used by the microprocessor to establish the day of the week. If a different day of the week is entered, it is automatically revised to agree with the day of the week as determined by the calendar information. If you have entered the correct day of the week and it is revised by the micro-

processor, review and correct the calendar information.
Proceed to SET SCHEDULE TIMES.

2—SET SCHEDULE TIMES (Place mode selector in SET mode)

- The display should be prompting "- --:--".
- Press a day keypad to select the DAY (SUN thru A1), the numbered keypads to select the HOUR and MINUTE the load is to switch, then either AM or PM (12:00 PM is noon).
- The display shows "X XX XX". If the day of week selected is alternate day A1 "8 XX XX" is displayed.
- Press the ON/COPY or OFF keypads to enter the desired operation for the Day and Time selected.
- Repeat for all days (Sun thru A1) as required.

3—COPY A DAY SCHEDULE TO ANOTHER DAY(S) (Place mode selector in SET mode)

The COPY FEATURE copies schedule times from one day to any other day or days.

Once this is done, the set points for that "copied to" day(s) CANNOT be modified in any way until the copy feature is cleared. The day that is being copied (copy from day) CAN BE modified at any time as required. These changes are automatically recognized by the "copy to" day (s). Copied days cannot be copied to. "Copied to" days cannot be copied from.

- The display should be prompting with the last schedule time entered or "- --:--" if SET mode is just entered.
- Press a DAY keypad to select the "copy to" day.
- Press the ON/COPY keypad.
- Press a DAY keypad to select the "copy from" day.
- Repeat for All Copied Days.

EXAMPLE: Mondays program is copied to Tuesday thru Friday; Tuesday thru Friday are the "copy to" days and Monday is the "copy from" day.

Note that the COPY feature copies IDENTICAL data from one day to another day (s).

• REVIEW ALL CALENDAR, HOLIDAY, AND SCHEDULE DATA (Mode selector in REVIEW MODE)

1—REVIEW (OR OMIT) MONTH/DATE, YEAR, DST AND HOLIDAY DATA

Press CLK/HLDY: All CALENDAR DATA IS AUTOMATICALLY displayed as follows:

"XX XX" MONTH/DATE
"Yr 87" YEAR for 1987
"S X XX" DST for Spring
"F XX XX" DST for Fall

"HLDY" To identify that holidays are to follow

"X XX XX" Holiday Month and Date, and the day

schedule for that holiday are displayed. Holidays are displayed chronologically beginning Jan 1st (1 01) regardless of the order in which they were entered.

The display will show "End" after all holidays have been reviewed.

TO REMOVE CALENDAR DATA FROM PROGRAM

- Press the CLK/HLDY keypad again when the data to be removed is displayed. The display will pause.
- Press the CLEAR (C) keypad: Displays "- --:--" The data that was displayed is now removed from the program.
- Press the CLK/HLDY keypad to continue the automatic review process, if desired.

Note: Pressing CLEAR WITHOUT PAUSING the display has NO AFFECT ON DATA.

• New data may be re-entered, if desired, by following applicable steps of instructions: "SET CALENDAR, HOLIDAY AND DAYLIGHT SAVING TIME DATA".

2—REVIEW OR OMIT SCHEDULE TIMES

- Press the DAY keypad (SUN thru A1) to select the day for circuit being reviewed.
- The display will prompt one of the following:
"X CP YX" Indicating that the day being reviewed is a copy of another day, shown as X.
"End" Indicating that there are no ON or OFF set points.
"--:--" Indicating that there may be set points.
- Press the ON/COPY or OFF keypads, in any sequence, to review the schedule times for the day selected. Schedule times are displayed in chronological order beginning at midnight, (12:00 AM), regardless of the order in which they were entered. Because of this, several on or off times may be shown in sequence. The display will show "End" after all ON and/or OFF set points have been reviewed.

TO REMOVE A SCHEDULE TIME(S) FROM THE PROGRAM:

- Press ON/COPY or OFF keypads until setpoint to be omitted is displayed.
- Press the CLEAR (C) keypad.
- The display shows "- --:--". Indicating that the schedule time that was displayed is now removed from the program.
- Press the ON/COPY or OFF keypad, in any sequence, to continue the review, if desired.
- Review can be terminated by exiting review mode.
- Repeat this procedure for all days as desired.

3—AUTO REVIEW OF SCHEDULE TIMES

- Press the DAY keypad to select the day being reviewed.
- Press the ON/COPY AND OFF keypads SIMULTANEOUSLY. The display shows "On" or "OFF" momentarily then displays the ON or OFF schedule time for 3 to 4 seconds. The schedule times are displayed in chronological sequence beginning at midnight, (12:00 AM), regardless of the sequence in which they were entered. Because of this, several on or off times may be shown in sequence.
- The display prompts "End" after all ON and OFF set points have been reviewed.

TO REMOVE A SCHEDULE TIME IN AUTO REVIEW:

- Press either the ON/COPY or OFF keypad when the time to be removed is being displayed. The Auto Review will pause.
- Press the CLEAR (C) keypad, the display shows "- --:--". The scheduled time is now removed from the program.
- Press the ON/COPY and OFF keypads simultaneously to continue the Auto Review of schedule times, or press either the ON/COPY or OFF keypad to step through programmed schedule times one at a time. Repeat this procedure for all days as desired.

Automatic review may be prematurely terminated by either momentarily exiting review mode or by pressing any day keypad.

MAKE SURE TO MOVE MODE SELECTOR BACK TO "AUTO", MODE AFTER SETTING OR REVIEWING

RESET does not Clear Set Point Memory; Reset initiates the system self diagnostic cycle.

Note that RESET will cause the time to be reset to 10:00 AM; the correct time and day must be reprogrammed.

TO CLEAR THE ENTIRE MEMORY press the CLEAR (C) keypad while the recessed MEMORY CLEAR (MC) switch is held depressed.

SAMPLE WIRING DIAGRAMS

The following wiring diagrams are typical wiring for various applications of the ET7115C Electronic Time Switch.

CAUTION:

- FOLLOW ALL LOCAL ELECTRICAL AND SAFETY CODES, AS WELL AS THE NATIONAL ELECTRICAL CODE (NEC).
- FAILURE TO OBSERVE THE CORRECT INPUT POWER CONNECTIONS FOR THE AVAILABLE VOLTAGE MAY CAUSE DAMAGE TO THE TIME SWITCH.
- DO NOT EXCEED THE MAXIMUM CURRENT CAPACITY OF THIS TIME SWITCH. THIS TIME SWITCH MUST BE GROUNDED.

SAMPLE SCHEMATIC FOR DIRECT CONTROL OF 277 VOLT LOAD

In this wiring diagram, a 277 volt fluorescent strip lighting load is being controlled. In this example, a separate 277 volt A.C. input is connected to the common terminal of the time switch with the normally open terminal of the time switch connected to one side of the load and the opposite side of the load to the other side of the 277 volt supply. As shown in the diagram, which follows, 120 volt A.C. input is supplied to terminals #2 and #4. In this example, either hot or neutral may be connected to either timer input terminal

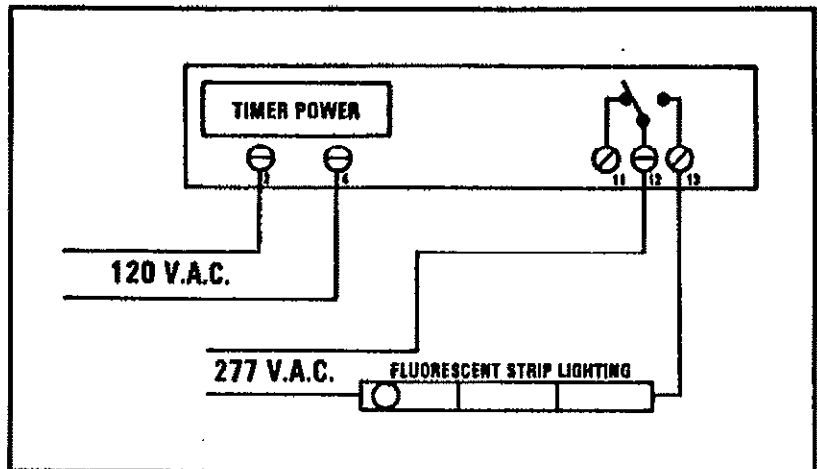

SAMPLE SCHEMATIC FOR DIRECT CONTROL OF 120 VOLT LOAD

In this wiring diagram, a lighting load is being directly controlled by the time switch contacts. Since both the timer input power and the controlled lighting load are 120 volts A.C., the timer input power is in parallel with the load control contacts. The output contacts are isolated from the timer input power. By following this diagram, power can be supplied to the load. Although the timer input power has no polarity, terminal #2 is identified as the "hot" input. This is due to the fact that terminal #2 is in parallel with the common terminal identified as terminal #12. This ensures that the hot side of the supply power is switched. The neutral side of the supply power is then connected to the opposite timer input power, indicated by terminal #4. Terminal #4 is wired in parallel with the other side of the lighting load. The normally open contact or terminal #13 is connected to the other side of the controlled load.

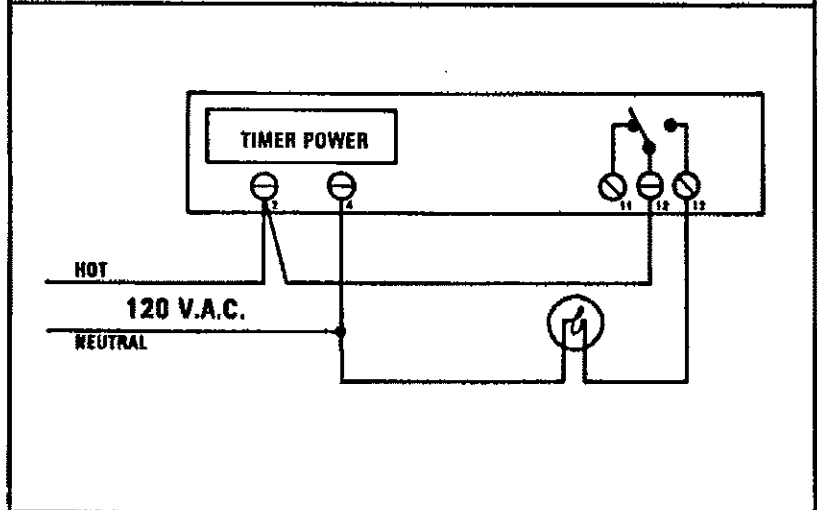

SAMPLE SCHEMATIC FOR LOW VOLTAGE SET-BACK - SETUP CONTROL

Both the normally open and normally closed contacts are used to enable setback and setup temperature control for air conditioning. In this example a separate 24 volt A.C. supply is connected to one side of a definite purpose contactor and to the common terminal of the time switch identified as terminal #12. The normally open contact, terminal #13, is connected to the setup thermostat, which is set to maintain the temperature at 74 degrees. The setback thermostat, which is set for 90 degrees, is connected to the normally closed contact, terminal #11. The other side of both thermostats is then connected to the other side of the contactor which is powered by the 24 volt A.C. supply. The contactor, a two pole device, is used to break both sides of a 240 volt supply to the compressor motor.

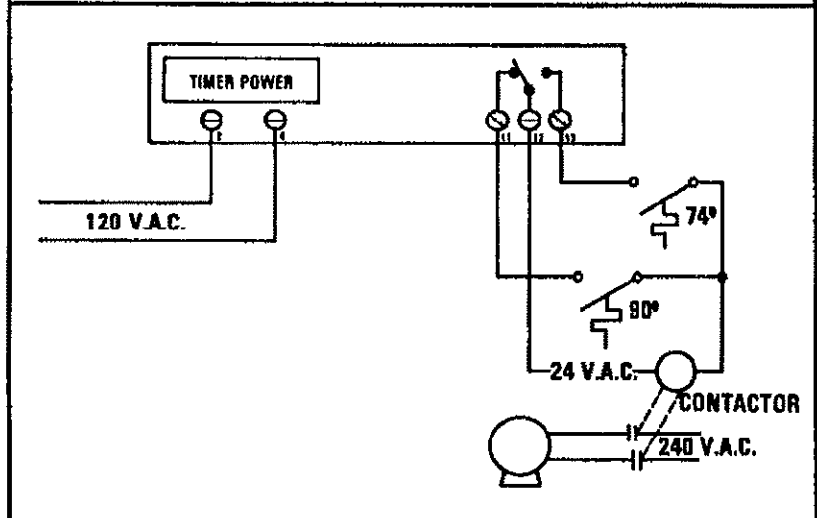

During occupancy periods, the time switch is programmed for an ON time which allows current to flow through from the normally open terminal and supply power to the contactor if the thermostat contacts are closed. During non-occupied times, the time switch is programmed for an OFF time causing the time switch contacts to remain as shown in the wiring diagram. This allows the temperature to rise to a maximum of 90 degrees. Depending on local code requirements, the contactor can be located remotely, near the compressor motor with electrical connections made using low voltage wiring without conduit being required.

The ET7115C Electronic Time Switch offers unlimited versatility for a variety of load controls. Be sure to review and observe the voltage and current ratings of the time switch contacts. If the load being controlled exceeds these ratings, a control interface device must be used as a means of preventing premature contact failure.

CONTROLS, SHOWN EXTERNAL TO THE TIME SWITCH, ARE NOT INCLUDED WITH THE TIME SWITCH.

TROUBLESHOOTING

Symptom	Possible Causes	Corrective Action
Load fails to switch	<ul style="list-style-type: none"> ● Faulty wiring ● Program in error 	Check wiring; attempt to cycle load using manual pushbuttons. Check all holiday, set point data and daylight saving dates programmed.
Erratic operation	<ul style="list-style-type: none"> ● Electrical noise can be interfering with the microprocessor 	<p>Install surge suppressors across all contacts switching inductive loads.</p> <p>Suppressors across external contacts can be added, but are not normally required. Be sure the time switch case is securely grounded to a good earth ground. Isolation relays may be used to isolate electrically "noisy" loads.</p>
No operation at all. No display.	<ul style="list-style-type: none"> ● No power to time switch. 	Check wiring to time switch supply terminals.
"EE:EE" in display	<ul style="list-style-type: none"> ● An error has been made in programming. 	Press CLEAR (C) keypad to remove "EE:EE". Review programming instructions.
"FULL" in display	<ul style="list-style-type: none"> ● The maximum number of set points have been used. 	Remove holidays or set points no longer required. Additional set points can now be entered.
Loss of program after long term power outage.	<ul style="list-style-type: none"> ● Solid state 24 hr. backup depleted. 	Reprogram time switch.
Erratic operation, loads fail to switch or display is dim.	<ul style="list-style-type: none"> ● Low line voltage or error in timer supply wiring. 	Verify that time switch supply voltage is correct as indicated in sample wiring diagram.
Keyboard and/or display inoperative.	<ul style="list-style-type: none"> ● Microprocessor is "locked up". 	Press RESET button for 5 to 10 seconds. If problem still exists, remove line power, wait 5 minutes then reapply power.
Calendar incorrect or automatic day of week calculation incorrect.	<ul style="list-style-type: none"> ● Memory loss due to extended power outage greater than (24 hrs.) 	Re-enter calendar data after first clearing wrong data in review.
Clock runs 4 seconds slow each minute after long power failure.	<ul style="list-style-type: none"> ● Micro processor not correctly initialized. 	Remove line power to timer for at least 5 seconds then re-apply.
Time switch did not adjust for daylight saving time.	<ul style="list-style-type: none"> ● DST date incorrect. ● Both DST dates not entered. 	Check for correct dates and be sure both Spring and Fall dates are entered.