

Distribution Transformers

Mineral Oil-Immersed, Self-Cooled, 60 Hertz Voltages and Connections

R201-90-2
Reference Data

CONTENTS

POPULAR DISTRIBUTION TRANSFORMER AND CIRCUIT VOLTAGES	1
2400-Volt Systems and Transformers	1
4160-Volt Transformers	2
4800-Volt Systems and Transformers	2
7200-Volt Systems and Transformers	2
7620-Volt Transformers	2
12,000-Volt Systems and Transformers	2
13,200-Volt Systems and Transformers	2
24,940-Volt Systems and Transformers	3
DISTRIBUTION TRANSFORMER TAPS	3
DISTRIBUTION TRANSFORMER POLARITY	3
TRANSFORMER CONNECTIONS	4
Single Phase	4
For Lights	4
For Power	4
For Light and Power	4
Hooked in Parallel	4
Two Phase	4
Three Phase	5
Polarity Effects	5
Standard Angular Displacement	5
Delta-Delta for Power	6
Delta-Delta for Light and Power	7
Open-Delta for Power	8
Open-Delta for Light and Power	9
Y-Delta for Power	10
Y-Delta for Light and Power	11
Y-Delta with One Unit Missing	12
Delta-Y for Light and Power	12
Y-Y for Light and Power	13
Y-Y Autotransformers for Supplying Power to 2400-Volt Motors from a 2400/4160-Volt Three-Phase Four-Wire System	13
Scott Connection Three-Phase to Two-Phase	14
Scott Connection Two-Phase to Three-Phase	14
Scott Connection Three-Phase to Three-Phase	15

POPULAR DISTRIBUTION TRANSFORMER AND DISTRIBUTION CIRCUIT VOLTAGES

2400-VOLT SYSTEMS AND TRANSFORMERS

In any particular voltage class, the actual rated voltage of a transformer has increased in years past. For example, the 2400-volt class of transformers formerly were rated 2200-110/220, then later they were rated 2300 115/230 and today they are rated 2400-120/240 volts. This gradual increase in the rated voltage of transformers also occurred in the other voltage classes. Throughout the following material, we will speak of a particular voltage class by using present day rated voltage terminology.

In the early days of urban-electrical distribution, practically all systems were 2400-volt class, delta systems, and the 2400-volt transformer was designed and manufactured for this system. The selection of 2400 volt for distribution was logical from the standpoint of service and economy. This voltage is high enough to give good system performance on systems where the distribution circuits are not very long. In addition, the voltage is sufficiently low to result in economical distribution equipment.

In recent years most 2400-volt delta systems have been changed over to 2400/4160Y-volt systems. This change was due to the fact that as the 2400-volt delta systems became more heavily loaded it became necessary to put in larger distribution-line conductors or raise the operating voltage in order to maintain proper voltage regulation. The most economical procedure in this case was to raise the operating voltage to 4160Y, and this was economical because the change did not necessitate a change in transformers or other equipment on the line.

2400/4160-volt distribution systems are used in most urban areas throughout the country. Another factor that has contributed to the change from delta to Y systems is surge protection. The three-phase four-wire solidly grounded Y system affords good grounds for surge arresters, and therefore, this system is superior from the standpoint of surge protection.

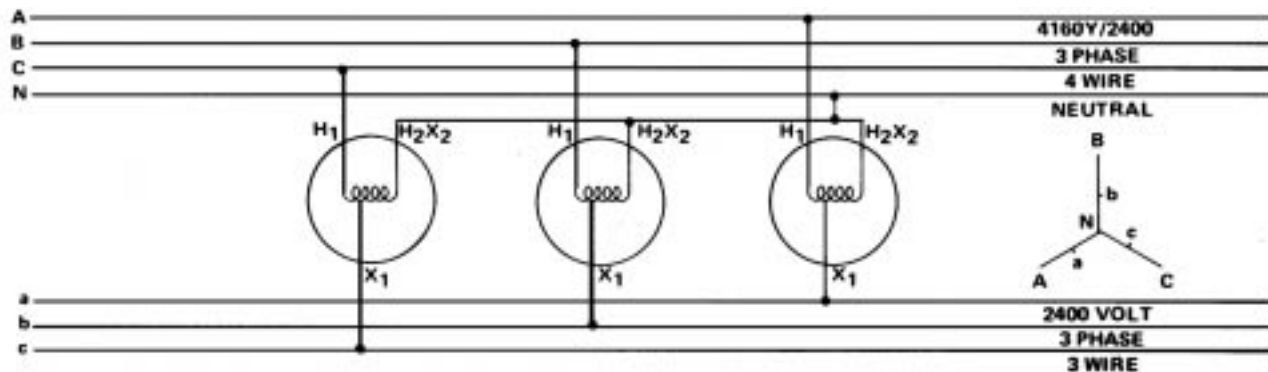

4160-VOLT TRANSFORMERS

The 4160-volt transformer came about through the 4160Y-volt connection on 2400-volt transformers. In some cases, it was advantageous to connect transformers between phase wires on a 2400/4160Y-volt system, and this required a transformer having a winding voltage of 4160 volts. These 4160-volt transformers are now used in several ways. First, they are used in three-phase delta banks connected to 2400/4160Y-volt systems.

Another application is for a 4160-volt single-phase line taken off of a 2400/4160Y-volt three-phase system. On this single-phase line, it is necessary to use 4160-volt transformers.

In recent years, rural electrification has expanded greatly, and in some cases, the 4160-volt line of transformers is used for rural systems rated 4160/7200Y. With this system, 4160-volt transformers can be used between phase wire and neutral of a three-phase four-wire system, and 7200-volt transformers can be used between phase wires.

4800 VOLT SYSTEMS AND TRANSFORMERS

The 4800-volt line of transformers is quite popular in some sections of the United States where distribution circuits run through thickly populated rural and suburban areas. Distribution lines in these localities are necessarily much longer than in cities, and therefore, the 2400-volt system is not high enough voltage to be economical. 4800-volt distribution in these areas has proved to be quite logical and satisfactory.

Here again, the systems originally were 4800-volt delta, three-phase systems with 4800-volt, single-phase branch lines. These delta systems have now been changed in some cases to 4800/8320Y giving a higher system voltage but using the same equipment that was used on 4800-volt delta systems. This change came about due to increased load on the line, and this change is quite similar to the change that took place in the 2400-volt delta system.

7200 VOLT SYSTEMS AND TRANSFORMERS

Rural electrification in thinly populated areas required still higher voltage for good performance and economy. Therefore, for rural electrification in the mid-west, south, southwest and western sections of the United States, 7200-volt distribution systems have been used quite extensively and successfully. The early rural systems were 7200-volt delta, three-phase in most cases, with 7200-volt single-phase branch lines. These systems have now given way to 7200/12,470Y-volt three-phase four wire systems. This change became necessary due to the fact that existing 7200-volt delta, three-phase lines became more heavily loaded and also due to the fact that rural lines have been extended to much greater length than formerly.

For strictly rural electrification in the sections of the country mentioned above, the 7200/12,470Y-volt three-phase four-wire system is by far the most popular today. 7200-volt single-phase branch lines are run for considerable distances from the three-phase four-wire main lines. On these single-phase branch lines, the so-called

single-bushing rural transformer has been used. This is a line of 7200-volt, single-phase transformers with only one high-voltage bushing mounted on the cover, and the other side of the high-voltage winding is permanently connected to the tank. This type of rural transformer is a part of rural-distribution construction designed for economy.

Most of the single-phase rural lines today have one hot wire carried on an insulator on top of the pole and one ground wire carried on the side of the pole at some distance from the top. The 7200-volt rural transformer is mounted directly to the pole with through-bolts, thus eliminating crossarms, crossarm braces, etc. Connection is made between the high voltage bushing and the hot wire on top of the pole, and the tank is connected to the ground wire carried on the side of the pole. This type of rural distribution system is much more economical than the type that was used some years ago, and as a result, it is now economical to serve many more rural customers than in previous years.

7620-VOLT TRANSFORMERS

7620-volt line of transformers is also used for rural electrification but this voltage is less popular than the 7200-volt class. Some 7620-volt delta three-phase systems have been used but practically all 7620-volt systems now are 7620/13,200Y-three-phase four-wire systems. On this system, 7620-volt single-phase transformers can be used between phase wire and neutral of the three-phase four-wire system or 13,200-volt transformers can be used between phase wires. The 7620/13,200Y-volt distribution system works out very economically for companies that have both 7620-and 13,200-volt distribution. In this situation, transformers can be used on either system, thereby making stocks of transformers flexible.

12,000-VOLT SYSTEMS AND TRANSFORMERS

There are some 12,000-volt three-phase delta systems that were built some time ago for transmission and power over greater distances than were feasible in lower voltages. There are now two applications for 12,000-volt transformers. The first is for use on 12,000-volt delta three-phase systems and second, for use on 7200/12,470Y-volt systems. 12,000-volt transformer can be used between phase wires on the 7200/12,470Y-volt three-phase four-wire systems and such use is fairly common today.

13,200-VOLT SYSTEMS AND TRANSFORMERS

The 13,200-volt transformer also has two applications. First, for use on distribution systems that are 13,200-volt delta three-phase which were built to distribute electrical energy at considerable distance. The second application has already been mentioned in connection with the 7620/13,200Y-volt three-phase four-wire system. On this system, the 13,200-volt standard transformer can be used between phase wires of the three-phase four-wire system. This connection is made quite often when it is necessary to connect a three-phase bank of transformers to the 7620/13,200Y-volt three-phase four-wire systems.

In addition to use in rural areas, the 12,000-volt and the 13,200-volt distribution systems are quite often used in urban areas. In relatively large cities having considerable industrial loads, 13,200 and 12,000-volt lines are quite often run to serve industrial loads while the 2400/4160Y-volt system is used for the residential and commercial loads.

24,940-VOLT TRANSFORMERS

24,940 Grd Y/14,400-volt units have one end of the high-voltage winding grounded to the tank wall and are only suitable for use on systems having the neutral grounded throughout its length.

OTHER DISTRIBUTION VOLTAGES

System voltages to 69 kv have been designated as distribution, although transmission lines also operate at these same voltages. The trend is to convert these lines to four-wire distribution systems, and use transformers with primary windings connected in wye. As an example a multigrounded neutral is added to a 34,500 (or 34,400) volt system and 20,000 (19,920) volt transformers used to supply the customers. The system is also in use for new construction in high-load density areas.

DISTRIBUTION TRANSFORMER TAPS

Prior to 1941, the majority of distribution transformers purchased had taps in the high-voltage winding. In practice these taps were never actually used, and therefore, were a waste of money. Today transformers with taps are more carefully considered.

There are three situations where taps can actually be justified in service.

1. An operating company may have several districts operating at slightly different primary distribution voltages, such as 2400, 2280 and 2160 volts. This company logically would buy 2400-volt transformers with taps so that one stock of transformers could serve all districts. The over-all economy of such an arrangement would be good.
2. Operating companies may use slightly different primary voltages such as 12,000 and 11,000 volts. The manufacturer then finds that most economical results can be obtained by making one line of transformers for the two customers.

Thus a 12,000 volt line of transformers with taps will take care of both customers, and the result is greater volume of production on this particular line of transformers with resulting lower cost to the manufacturer and lower cost to the user.

3. Transformers serving power loads should have taps to compensate for full-load voltage drop in the power circuit.

For situations other than the above, taps are of little value.

American National Standards Institute no longer specifies taps in basic standard transformers designs but tapped transformers are still available for those that need them.

In connecting transformers in banks, either parallel banks or three-phase banks, the tap settings should be checked on the individual transformers. Tap settings should be identical on transformers in the same bank. The transformer ratios must be identical or circulating currents will result in many types of banks.

DISTRIBUTION TRANSFORMER POLARITY

Polarity of a transformer is simply an indication of direction of flow of current from a terminal at any one instant. The idea is quite similar to the polarity marking on a battery.

As you face the high-voltage side of a transformer, the high-voltage terminal on your right is always marked H_1 and the other high-voltage terminal is marked H_2 . This is an established standard.

By definition, the polarity is additive if when you connect the adjacent high voltage and low voltage terminals (Figure 1) and excite the transformer, a voltmeter between the other two adjacent terminals reads the sum of the high-voltage and low-voltage winding voltages. For additive polarity, the low-voltage terminal on your right when facing the low-voltage side should then be marked X_1 and the other low voltage terminal X_2 .

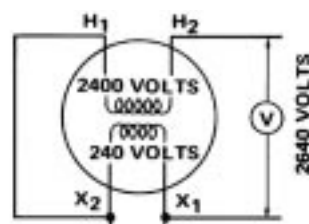

Figure 1
Additive Polarity.

For subtractive polarity, the voltmeter in Figure 2 reads the difference between the two winding voltages. In other words, the voltages subtract. In the case of subtractive polarity, the low-voltage terminal on your left when facing the low-voltage side is marked X_1 .

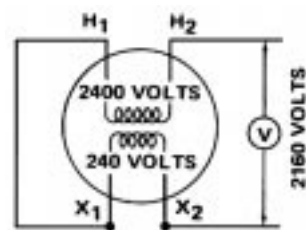

Figure 2
Subtractive Polarity.

Voltages and Connections

In making transformer connections, particularly bank connections, polarity of individual transformers must be checked. In making such connections it is necessary to remember that all H_1 terminals are of the same polarity and all X_1 terminals are of the same polarity. Thus, if you were connecting two single-phase transformers in parallel, you should connect the two H_1 terminals together, then the two H_2 terminals together, the two X_1 terminals together and the two X_2 terminals together. By following this procedure, you can satisfactorily parallel transformers regardless of whether they are both of the same polarity or whether one is additive and one is subtractive polarity.

The ANSI Standards for transformers specify additive polarity as standard on all single-phase units in sizes 200 kva and smaller having high-voltage windings 8,660 volts and below. All other units are subtractive polarity.

TRANSFORMER CONNECTIONS

SINGLE PHASE

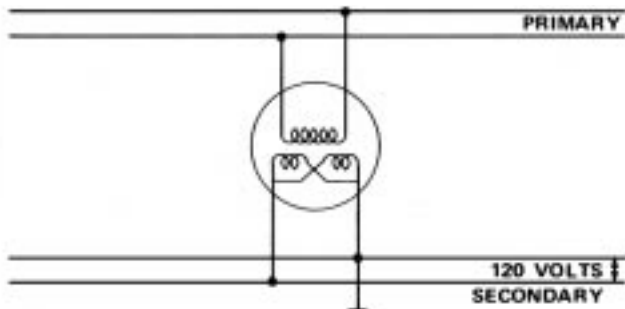

Figure 3

For Lights

Transformer is placed between high-voltage line and low voltage. The 120/240-volt low-voltage windings are connected in parallel. This type of connection would be used to supply one customer with 120 volts for lights.

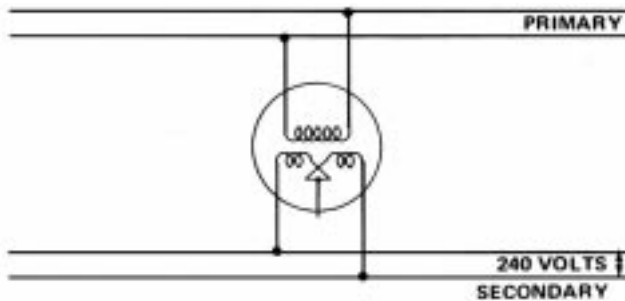

Figure 4

For Power

This connection is similar to single phase for lights except 120/240-volt low-voltage windings are hooked in series giving 240 volts on a two-wire system as shown.

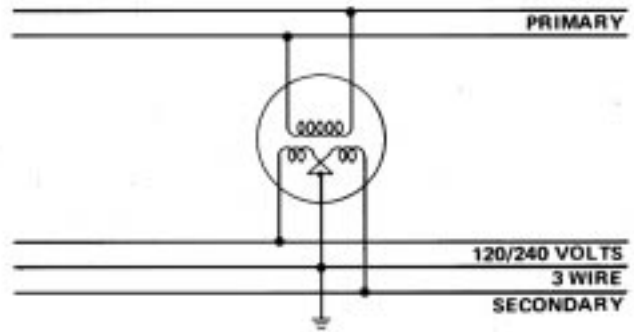

Figure 5

For Light and Power

This connection is the most common for city distribution. The three-wire system makes it possible to serve both 120 volt and 240 volt loads simultaneously.

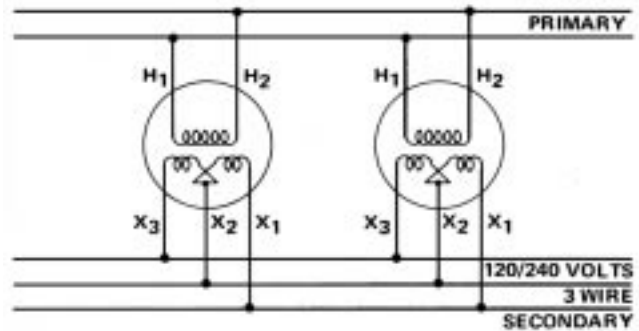

Figure 6

Hooked in Parallel

Two single phase transformers can be used in parallel on a single-phase three-wire system *if the terminals with the same relative polarity are connected together*. This is not a very economical operation because the individual cost and losses of the smaller transformers are greater than one larger unit giving the same output. This is mentioned as emergency operation for small transformers. In larger transformers, however, it is many times practical to operate units in parallel as a regular practice.

TWO PHASE

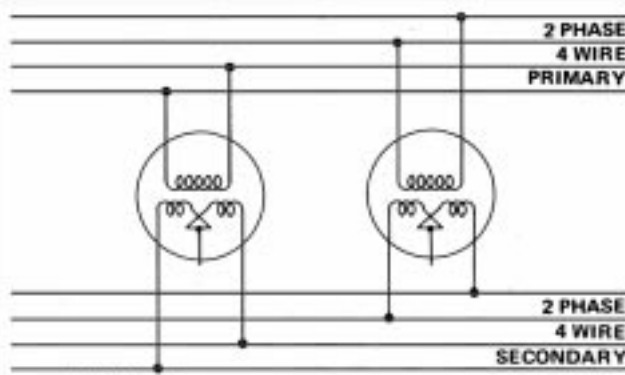

Figure 7

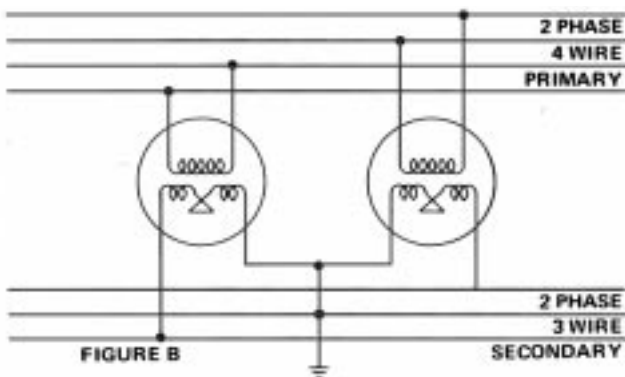

Figure 8

A two-phase system is simply two single-phase circuits operated 90° out of phase with each other. In Figure 7 they may be treated as two separate circuits. In Figure 8, however, there is a common wire on the secondary side resulting in some saving in copper. The common wire must carry 1.41 X current in other secondary wires.

THREE PHASE

Polarity Effects

Any combination of additive and subtractive units can be connected in three-phase banks so long as the correct polarity relationship of terminals is observed. Whether a transformer is additive or subtractive does not alter the designation of the terminals (X_1 , X_2 , etc.) thus correct polarity will be assured if connections are made as indicated in the diagrams. The terminal designations, if not marked, can be obtained from the transformer nameplate which shows the schematic internal-connection diagrams diagramming the actual physical relationship between the high and low voltage terminals.

If subtractive-polarity transformers are used in three-phase banks secondary connections are simplified from those shown for the additive-polarity units. The additive-polarity connections, for standard angular displacement, are somewhat complicated, particularly in cases with delta-connected secondary, by the crossed secondary interconnections between units.

For this reason simplified bank connections, which give non-standard angular displacement between primary and secondary systems, are sometimes used with additive-polarity units.

Standard Angular Displacement

Standard angular displacement or vector relationships between the primary and secondary voltage systems, as defined by ANSI publications, are 0° for delta-delta or wye-wye connected banks and 30° for delta-wye or wye-delta banks.

Angular displacement becomes important when two or more three-phase banks are interconnected into the same secondary system or when three-phase banks are paralleled. In such cases it is necessary that all of the three-phase banks have the same displacement.

The following diagrams cover three-phase circuits using:

1. Standard connections—where all units have additive polarity and give standard angular displacement or vector relation between the primary and secondary voltage systems (as defined by ANSI publications).
2. Simplified connections for the more common three phase connections with the delta-connected secondary— where all units have additive polarity but give nonstandard angular displacement between the primary and secondary voltage system.

Delta-Delta for Power

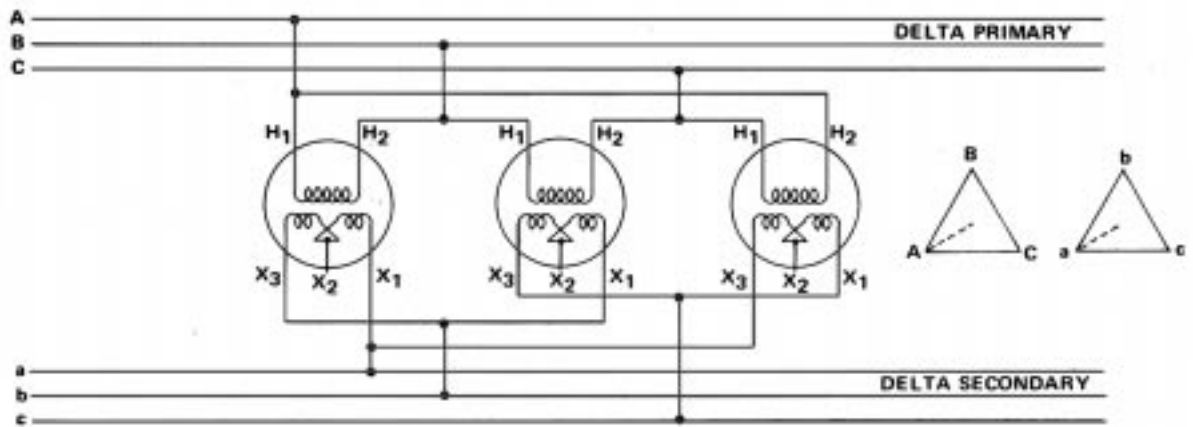

Figure 9

Standard Connection

This type of three-phase transformation has been the one most commonly used in the past. The ungrounded primary system will continue to supply power even though one of the lines is grounded due to a fault. If one

of the transformers in the bank should fail, secondary power can be supplied from the two remaining units by changing to the open delta connection. Thus this type of connection is ideal from the standpoint of service continuity.

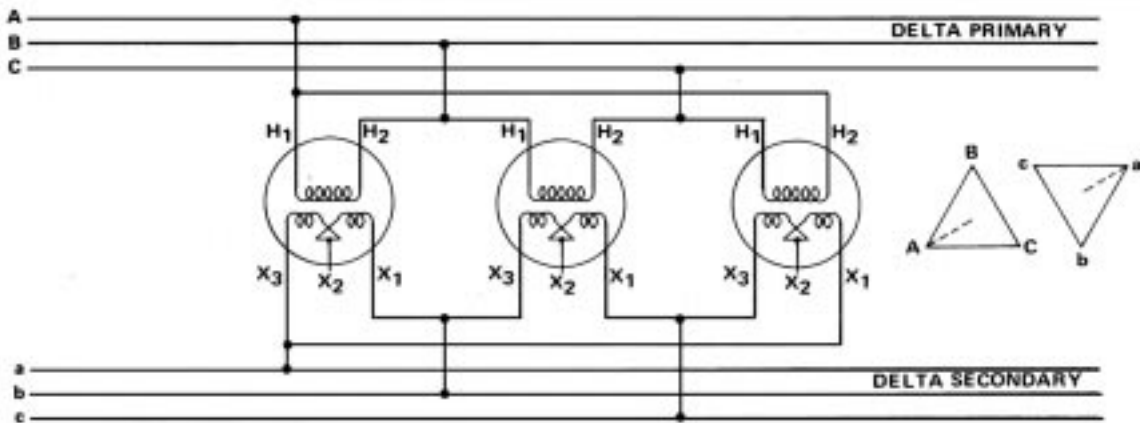

Figure 10

Simplified Connection

This is similar to the connection above but gives a 180° angular displacement which is non-standard. Otherwise the information given above is applicable to the connection.

Delta-Delta for Light and Power

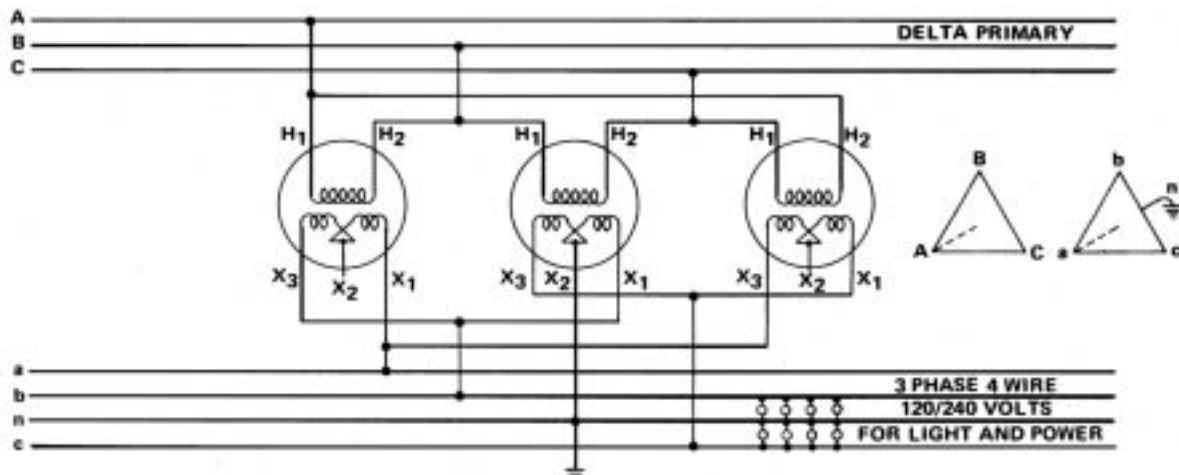

Figure 11

Standard Connection

When light and power are to be supplied from the same bank of transformers, the mid-tap of the secondary of one of the transformers is grounded and connected to the fourth wire of the three-phase secondary system as

shown in the diagram. The lighting load is then divided between the two hot wires of this same transformer, the grounded wire being common to both branches.

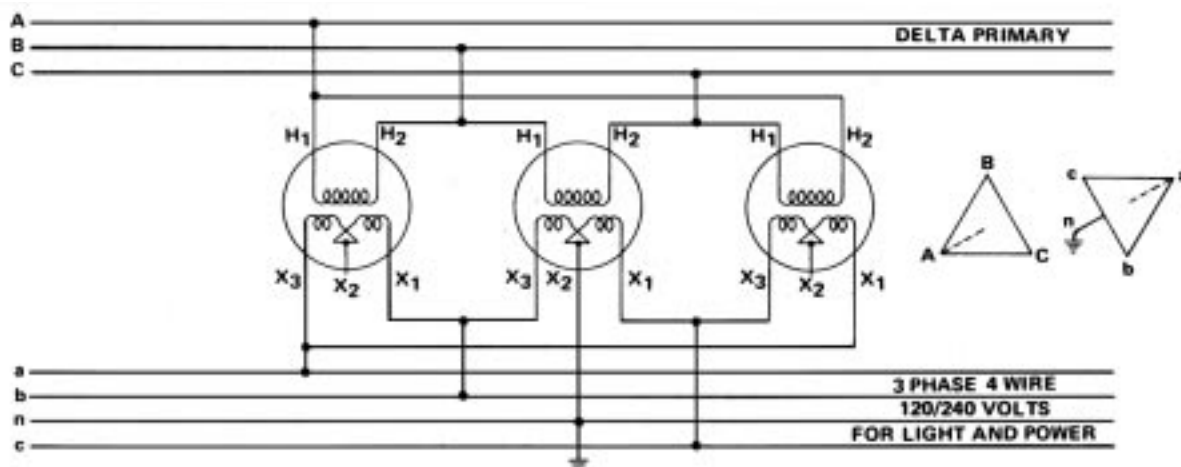

Figure 12

Simplified Connection

This is similar to the connection above but gives the non-standard 180° angular displacement. Otherwise the information given above is applicable to the connection.

Open Delta for Power

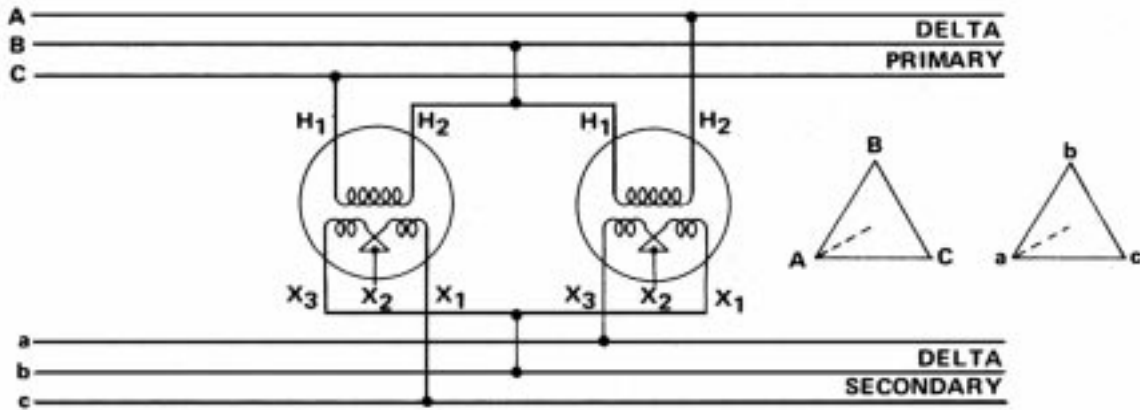

Figure 13

Standard Connection

As mentioned before, this connection can be used in an emergency in case one of the transformers in a delta-delta bank fails. This type of bank is also used to supply power to a three-phase load which is temporarily light but which is expected to grow. When the load increases to a point where the two transformers in the bank are overloaded, an increase in capacity of 1.732 times can be obtained by adding another unit of the same size and using the delta-delta connection.

The capacity of an open delta bank is only 57.7% of a delta-delta bank of the same size units. That is, three 25 kva transformers connected delta-delta would have a capacity of 75 kva. Two 25 kva transformers in an open delta bank would have a capacity of only 43.2 kva. It is convenient to remember that in an open delta bank only 86.6% of the capacity in the transformers is realized.

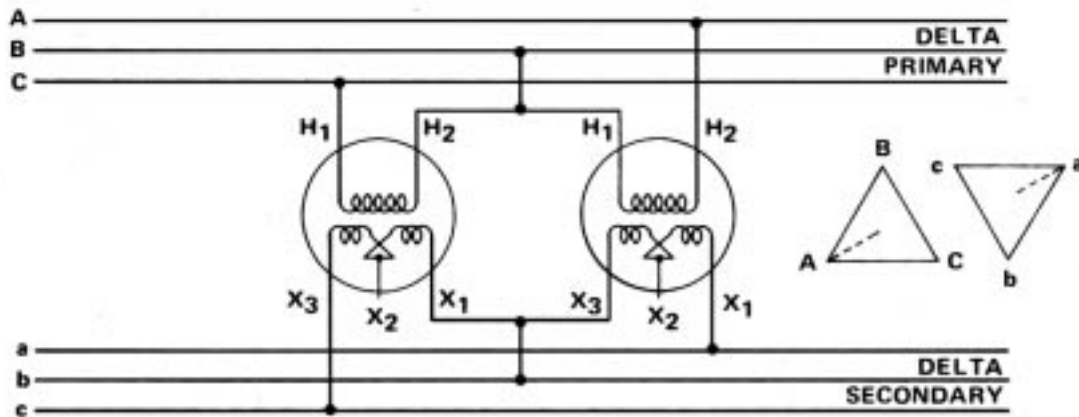

Figure 14

Simplified Connection

This is similar to the connection above but gives a 180° angular displacement which is non-standard. Otherwise the information given above is applicable to this connection.

Open Delta for Light and Power

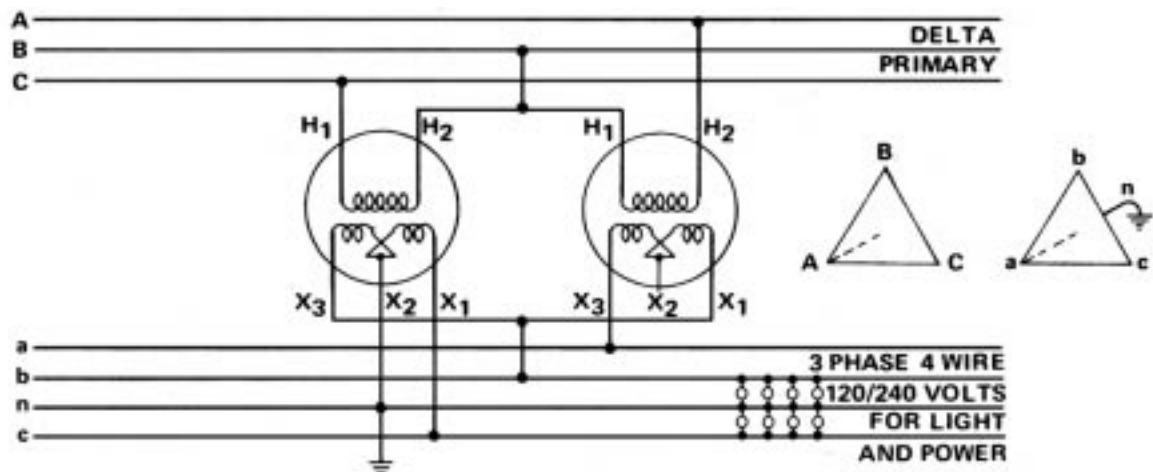

Figure 15

Standard Connection

When the secondary circuits are to supply both light and power, the open-delta bank takes this form. In addition to the applications listed above for the open-delta bank for power, this type of bank is used where there is a large single-phase load and only a small three-phase load. In this case, the two transformers would be of

of different kva sizes, the one across which the lighting load is connected being the larger. This is also the connection that should be used when protected transformers are employed in a three-phase bank supplying both light and power.

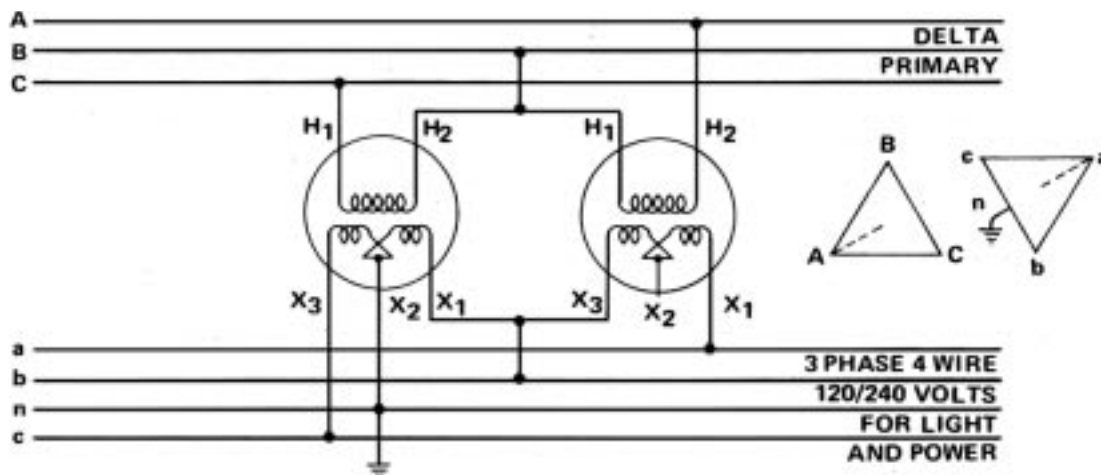

Figure 16

Simplified Connection

This is similar to the connection above but gives a non-standard 180° angular displacement. Otherwise the information given above is applicable to this connection.

Y-Delta for Power

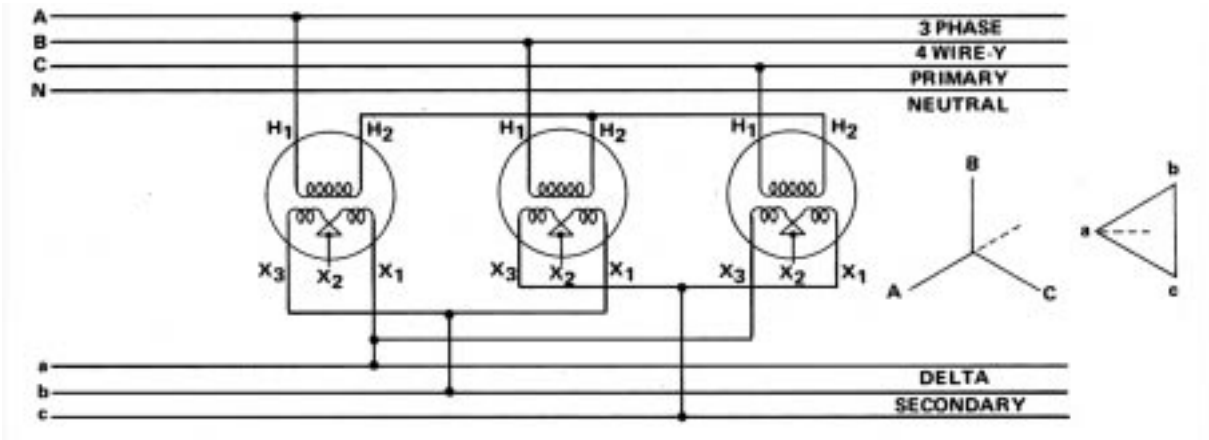

Figure 17

Standard Connection

The present tendency in utilities is to replace the 2400 delta system with the 2400/4160Y-volt three-phase four-wire system. This change in effect raises the distribution voltage from 2400 to 4160 volts without any major changes in connected equipment. The same transformers that were

previously connected between lines on the 2400-volt delta system are now connected between lines and neutral on the new 2400/4160Y-volt system. Three-phase banks that had previously been connected delta-delta are now connected Y-delta as shown.

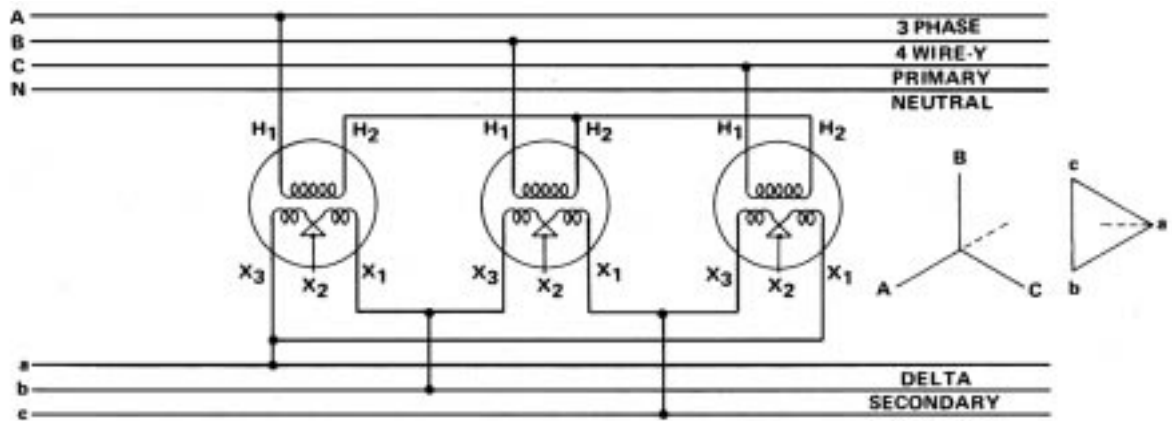

Figure 18

Simplified Connection

This is similar to the connection above but gives a 210° angular displacement which is non-standard. otherwise the information contained above is applicable.

Y-Delta for Light and Power

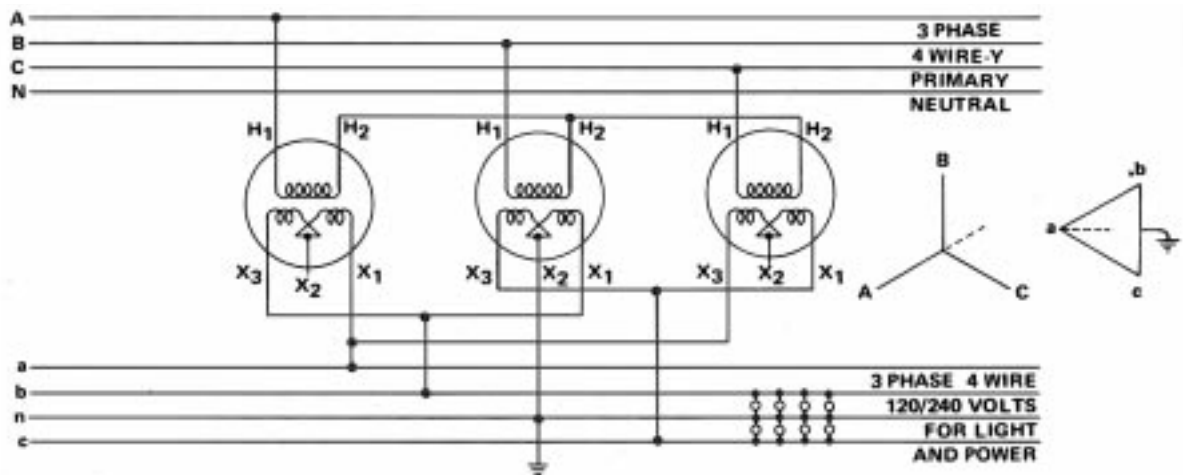

Figure 19

Standard Connection

When service for both light and power is to be supplied, the Y-delta bank takes this form. Note that the secondary connections are the same as for the delta-delta bank.

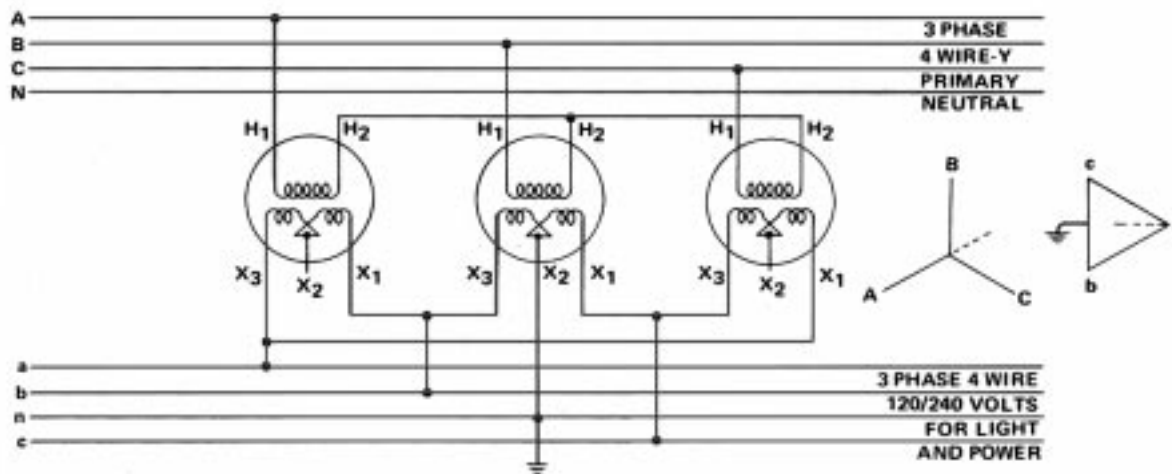

Figure 20

Simplified Connection

This is similar to the connection above but gives a non-standard 210° angular displacement. Otherwise the information contained above is applicable.

NOTE: Other connections on the delta-delta or wye-wye bank are possible by which an angular displacement of 60°,

120°, 240° or 300° can be obtained. In addition, an angular displacement of 90°, 150°, 270°, or 330° can be obtained on a wye-delta or delta-wye bank. These connections are not popular and hence are not discussed demonstrated here.

Y-Delta With One Unit Missing

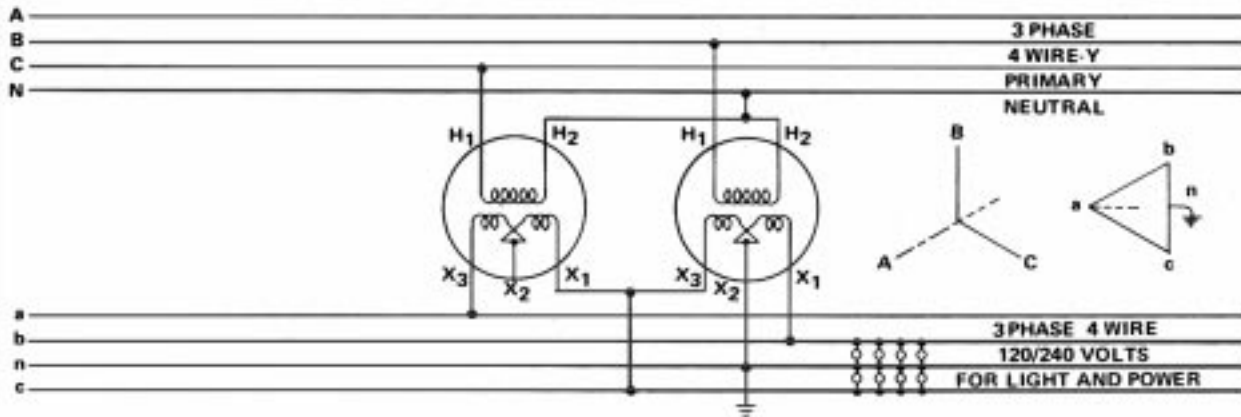

Figure 21

If one unit of a Y-delta bank goes bad, service can be maintained by means of this connection. In the regular Y-delta bank with three units, the neutral of the primaries of the transformers is not ordinarily tied in with the neutral of the primary system. In fact, this bank can be used even when the primary neutral is not available. In the bank with two units, however, it is necessary to connect to the neutral as shown. The main

disadvantage of this hook-up is the fact that full-load current flows in the neutral even though the three-phase load may be balanced. In addition to maintaining service in an emergency, this type of bank is satisfactory where the main part of the load is lighting and the three-phase load is small. This connection is for additive polarity units and gives standard angular displacement.

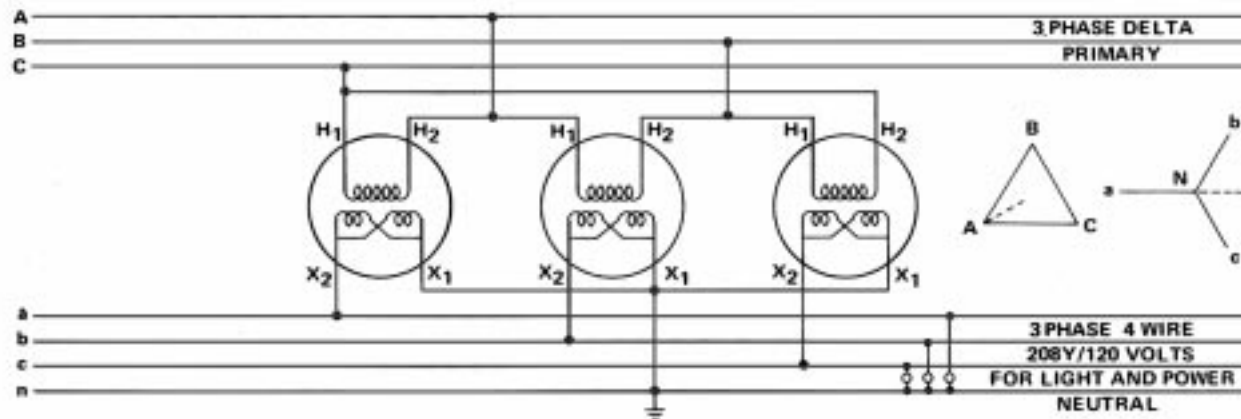

Figure 22

In all the banks mentioned above in which both power and lighting are served on the secondary, the grounded-secondary wire is not the neutral of the three-phase system but rather the mid-point of one leg of the delta. Furthermore, all the lighting load is put on one phase. The primary currents in any one bank, therefore, are unbalanced.

In order to obtain balanced currents at the substation or generator, the transformers supplying the lighting loads are connected to different primary phases in the different three-phase banks. This means that different legs of the delta are grounded in the various three-phase banks. This type of secondary connection can, therefore not be used when the secondaries of different banks

are to be paralleled or banked. In regions of high load density, superior operating characteristics are obtained when secondaries are banked. The delta-Y connection is most commonly used when this is done. Note that standard transformers with 120/240-volt secondary windings are used with the secondary of each unit connected for 120 volts. In this case, the neutral of the secondary three-phase system is grounded. The single-phase loads are connected between different phase wires and neutral while the three-phase power loads are connected to the three-phase wires. Thus, 120 volts is supplied to that the secondaries of different banks can be tied together. This connection is for additive polarity units and gives standard angular displacement.

Y-Y for Light and Power

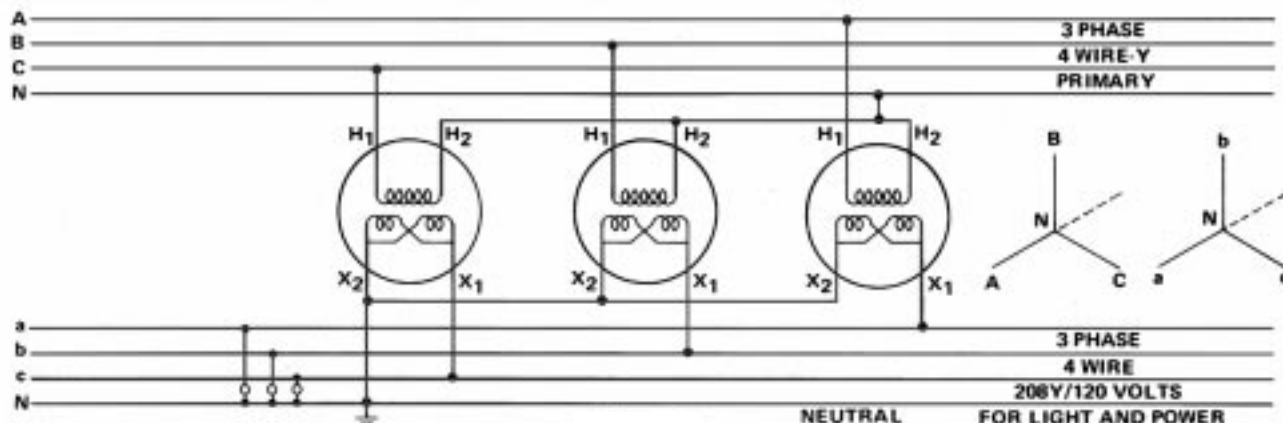

Figure 19

The primaries of the transformers can also be connected Y as shown. When the primary system is 2400/4160Y volts, 2400-volt transformers would be used in place of the 4160-volt transformers that would be required for the delta-Y connection. A saving in transformer cost results. It is necessary that the primary neutral be available when this connection is used, and the neutrals of the primary system and of the bank are tied together as shown. If the three-phase load is unbalanced, part of the load current flows in the primary neutral. Also the third-harmonic component of the transformer exciting current flows in the primary neutral. For these reasons, it is very necessary that the neutrals be tied together as shown. If this tie were omitted, the line to neutral voltages on the

secondary would be very unstable. That is, if the load on one phase were heavier than on the other two, the voltage on this phase would drop excessively and the voltage on the other two phases would rise. Also, large third-harmonic voltages would appear between lines and neutral, both in the transformers and in the secondary system, in addition to the 60-hz component of voltage. This means that for a given value of rms voltage, the peak voltage would be much higher than for a pure 60-hz voltage. This over-stresses the insulation both in the transformers and in all apparatus connected to the secondaries. Figure 17 shows this connection is for additive polarity units and gives the standard angular displacement.

Y-Y Autotransformers for Supplying Power to 2400-Volt Motors from a 2400/4160Y-Volt Three-Phase Four-Wire System

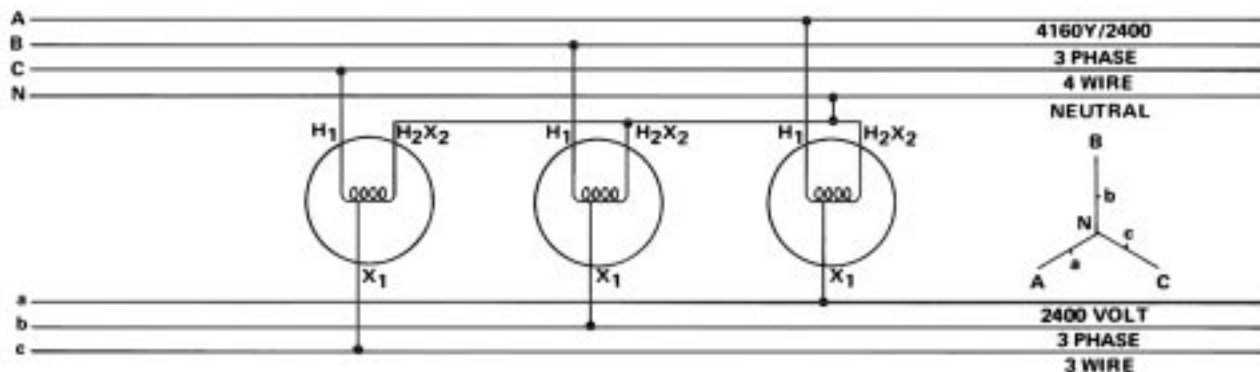

Figure 24

In the changeover from the 2400-volt delta to the 2400/4160Y-volt primary system mentioned above, there may be some customers with 2400-volt motors which cannot be connected directly to the new primary system. The cheapest way of adapting these motors to the new system is by means of a bank of autotransformers connected as shown. In this application, the size and cost of autotransformers is considerably less than for two windings delivering the same amount of power,

due to the fact that the ratio of transformation is small. For instance, if the three-phase load is 150 kva, the physical size and cost of the autotransformers would be comparable to about 21 kva for each unit. For the primary voltage shown, each of these autotransformers would have a 2400-volt winding with a tap at 1386 volts. Again it is important that the neutral of the autotransformer bank be tied in with the neutral of the primary system. This connection is for additive polarity units and gives the standard angular displacement.

Scott Connection Three-Phase to Two-Phase

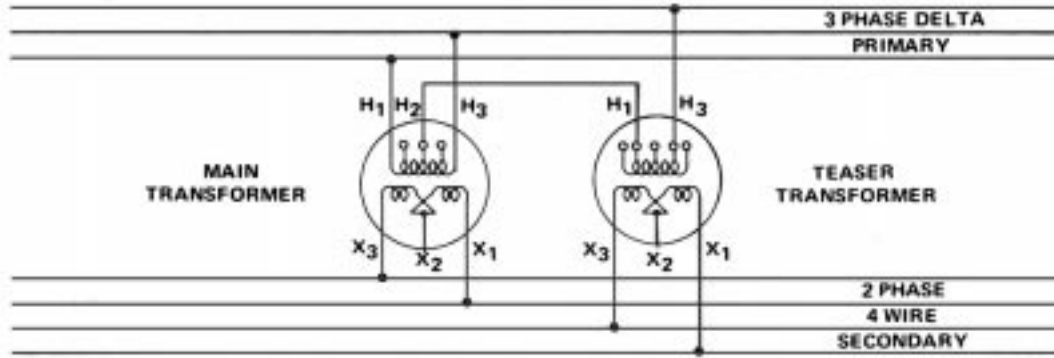

Figure 25

Many old distribution systems which originally were two-phase are being changed over to three-phase. Utilities making this changeover are faced with the problem of supplying power to customers having two-phase motors. The Scott bank is most generally used in this connection. The transformers are special in that they have taps at 50% and 86.6% in the primary winding. The currents in the primary windings of these transformers are 15 1/2% greater than when transforming single-phase at the same kva and voltage. This

means that a transformer with Scott taps built on the same core as a regular single-phase transformer will have only 86.6% of the kva capacity of the single-phase transformer. For instance, if transformers with Scott taps are built on cores that would normally be used on 50 kva transformers, the kva rating of two of these transformers in a Scott bank would only be 86.6 kva. This connection is for additive polarity units and gives standard angular displacement.

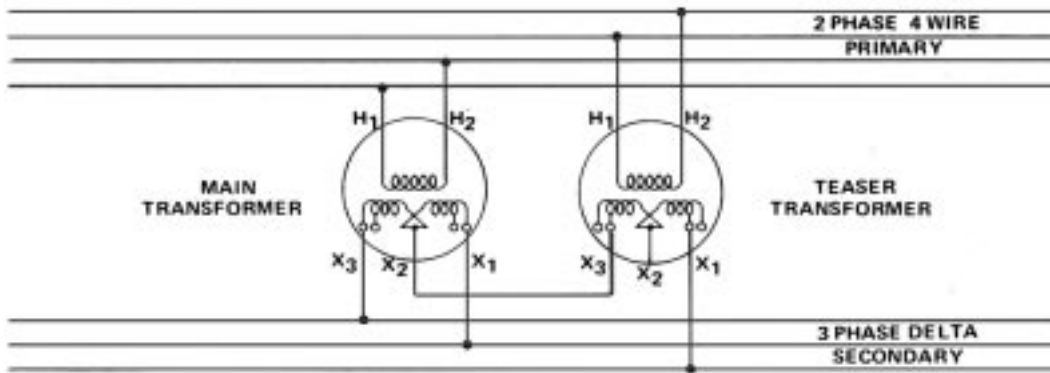

Figure 26

In the case of a factory being built in a district that is at present served by a two-phase system, three-phase rather than two-phase motors would probably be installed in the factory, since these are more standard, and since there is a good chance of the two-phase system being changed over to three-phase at some future date. Here the utility is faced with the problem of supplying three-phase power from a two-phase system. The Scott connection with three-phase on the secondary

performs this function. In this case, the currents in the secondary windings are 15 1/2% greater than in transformers delivering the same kva single-phase at the same voltage. This again causes the kva output of transformers with Scott taps in the secondary to be 86.6% of regular transformers of the same physical size. This connection is for additive polarity units and gives standard angular displacement.

Scott Connection Three-Phase to Three-Phase

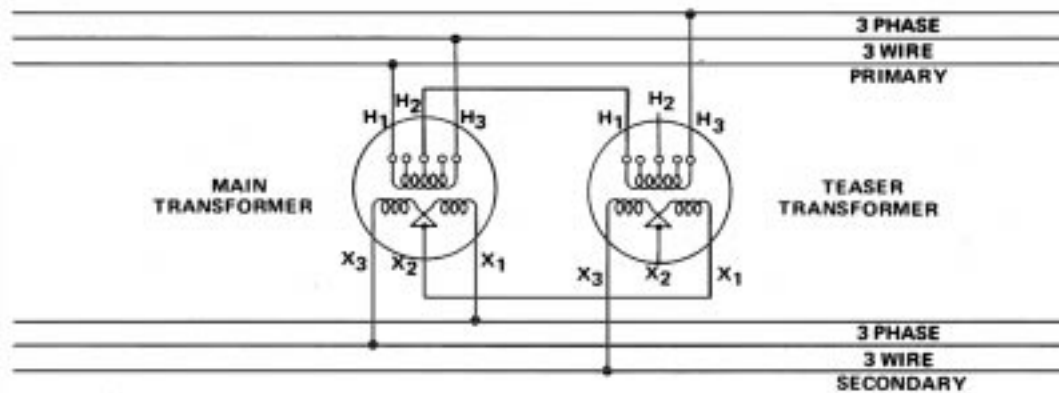

Figure 27

As two-phase systems are gradually changed over to three-phase, it is not necessary to replace the old two-phase banks, but just reconnect them. The teaser transformer will operate with 86.6% voltage on both the primary and secondary so it should have the same ratio

as the main transformer. The units in example 16 may be reconnected for three-phase service. Care should be taken to observe the same relative phase sequence of the windings as there can be a severe unbalance with the wrong connection.

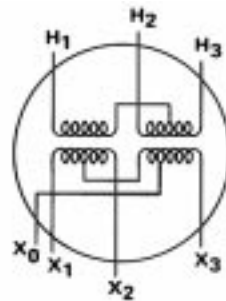

Figure 28

The modern version of this connection is in a duplex (two units in one tank) transformer, called a "Y" connection, which can simulate the various wye or delta connections except that no neutral will be made

available on the primary side. These "T" connected units will have a 30° angular displacement and may have a neutral on the Secondary side.



P.O. Box 1640
Waukesha, WI 53187