

Common PE3000RC Applications

PE30065RC Applications

240 V 2-Speed Pump + any three 240 VAC Auxiliary Equipment

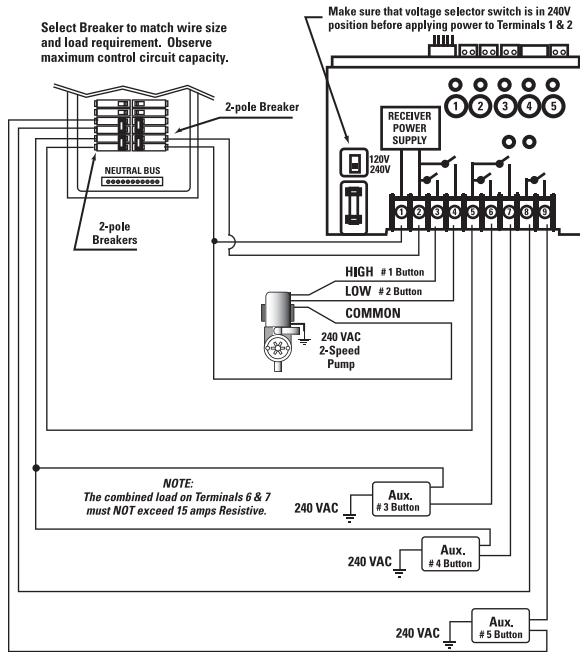

240 V 2-Speed Pump + Booster Pump + 120 V Light + Heater

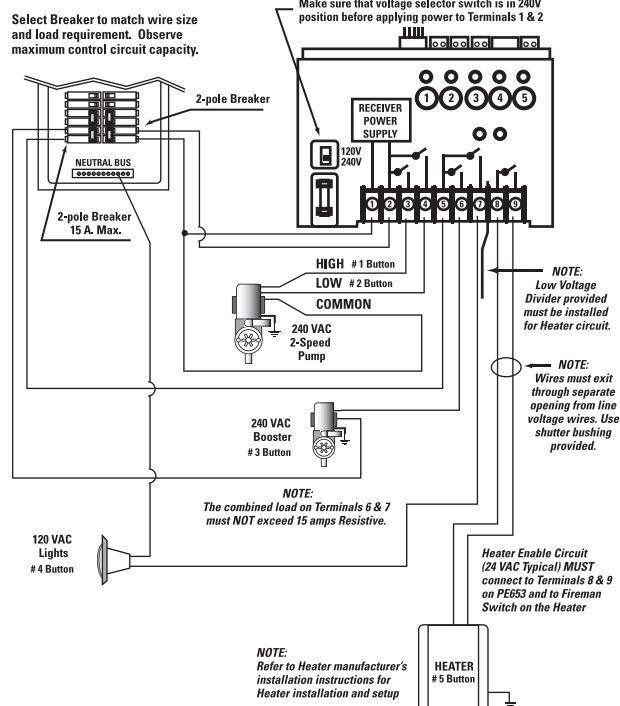

PE34065RC Applications

240 V 2-Speed Pump + 240 V Booster Pump + 240 V Actuator + Heater

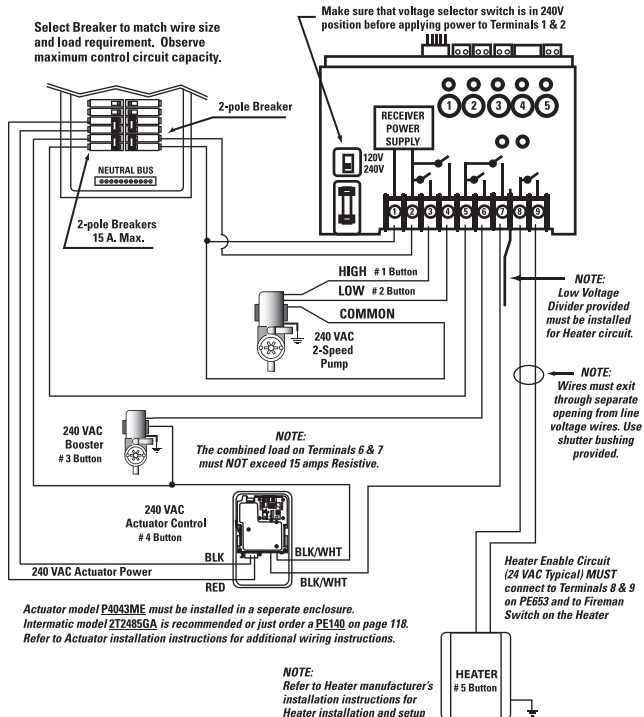

240 V 2-Speed Pump + 240 V Blower + 240 V Actuator + Heater

