

<http://waterheatertimer.org/Troubleshoot-Rheem-Tankless-water-heater.html>

Parts and accessories for residential and commercial indoor direct vent and outdoor eco-friendly tankless gas water heating systems from

- Rheem
- Ruud
- Rheem-Ruud
- Richmond
- EcoSense
- Paloma

TANKLESS

Parts & Accessories 2011

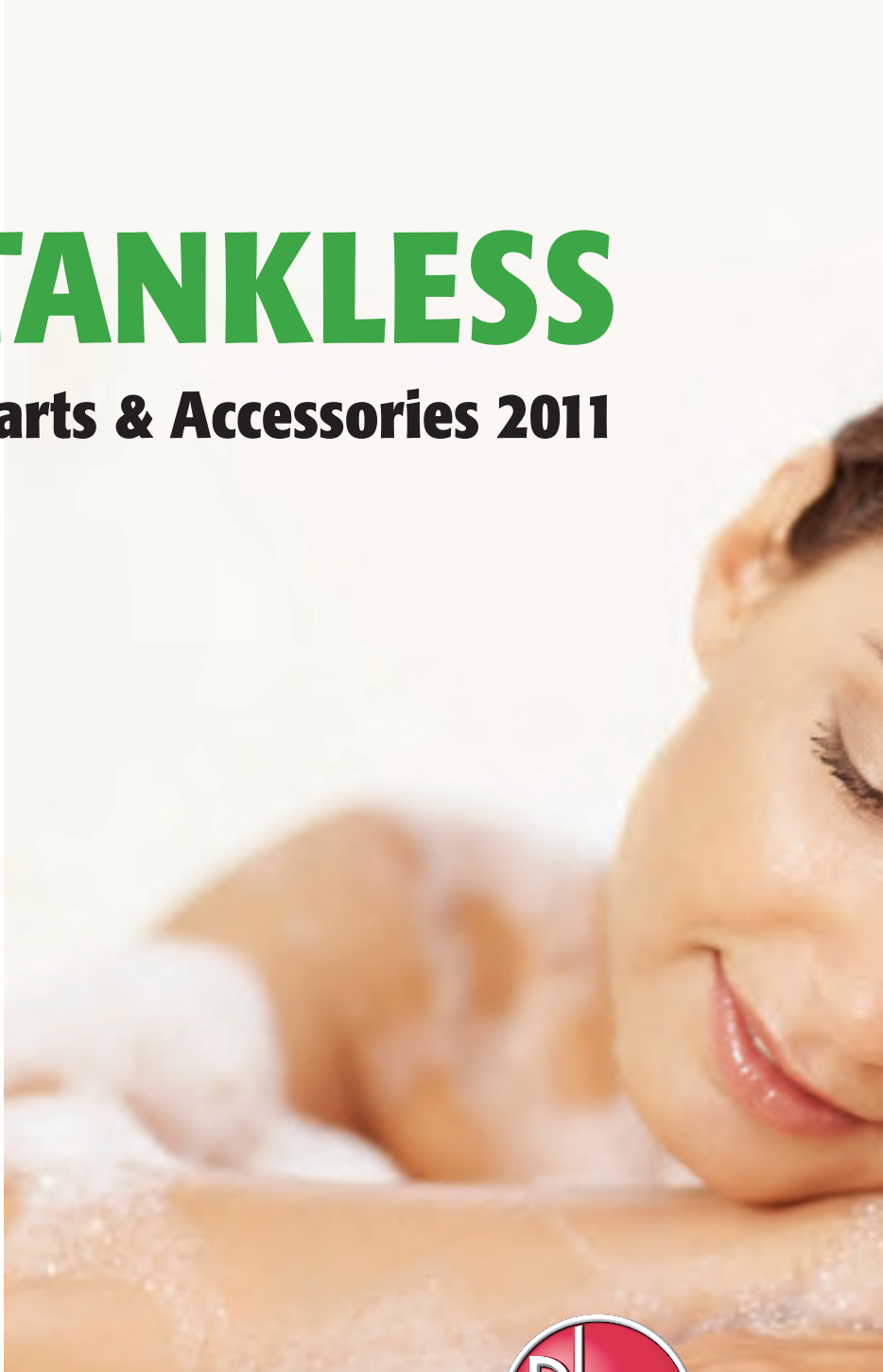

Tankless water heaters
Continuous hot water



relax
It's Rheem®



Rheem Advantages

It is the goal of Rheem to set the standard for the plumbing industry we serve, and to be the organization against which others are measured. We are market driven, and will continue to explore products and services that offer our customers a competitive advantage in the marketplace.

Technology

Rheem has significant research and development capability which allows us to offer the latest technology and product reliability to our customers.

Patented Products

Rheem has a number of patented products that allow us to offer the highest quality replacement parts.

Customer Service

Rheem has an industry-leading customer service team that can provide fast and convenient answers to our customers' questions.

Brand Equity

The Rheem and Ruud names are synonymous with quality and customer service and allows Rheem Parts and our partners to capitalize on this brand recognition with professional plumbers.

Business Partner

Rheem is a proven business partner to our customers.

Sales Professionals

Rheem Water Heating has an exceptional network of sales professionals to help our customers sell replacement parts.

More Rheem water heaters have been installed in homes than any other brand. Rheem has been providing reliable water heating to the world since we invented the water heater over 100 years ago.

Premier Customer Experience – *Priority One!*

Rheem Water Heating will be the premier customer experience provider of Rheem tankless water heaters. Rheem's philosophy of speed, accuracy and attentiveness will guide this initiative. This will be achieved through customer education, internal and external training, and after sales service.



Rheem Tankless Parts and Accessories

A comprehensive catalog of approved replacement parts for Rheem®, Ruud®, Rheem®-Ruud®, Richmond®, EcoSense™ and Paloma® tankless gas water heaters*.

General Terms and Conditions

Freight Allowance

Please see the Tankless Parts and Accessories Price Sheet for Freight Allowances.

Taxes

Prices are subject to the addition of any tax imposed by any present or future Federal, State, County or Municipal law on the sale of such material, unless we have a tax exemption certificate on file.

Acceptance of Orders

All orders are subject to final approval on the terms and conditions contained in our standard customer acknowledgment form.

Materials Return

Saleable, current component parts in a new or unused condition must have prior authorization by the Parts Packaging Supervisor or Customer Service before being returned. Parts may only be considered for return within 90 days from the original invoice date. Invoice numbers must be provided to Customer Service prior to obtaining a return authorization number. All parts returned without prior authorization will be destroyed or sent back to the sender at their expense. All returns will be subject to our inspection and a 25% restocking charge. Returned parts that are damaged or in a condition that prevents resale will not be credited. Service/Warranty Parts returned in accordance with warranty claim provisions do not require prior authorization, but will be subject to our inspection. See Price Sheet for Additional Conditions.

Accessories.....	2
Manifold Systems.....	3
Vent Kits.....	4
3"/5" Concentric Venting.....	5
RTG -53D V Parts.....	6
RTG -53X Parts.....	8
RTG -53P V, RTG 2-42P V Parts.....	10
RTG -66D V Parts.....	12
RTG -66X Parts.....	14
RTG -74D V & GT-199D V Parts.....	16
RTG -74X & GT-199X.....	18
RTG -74P V & GT-199P V Parts.....	20
RTG -95/84/64D V Parts.....	22
RTG -95/84/64X Parts.....	24
RTGH -95/84D V Parts.....	26
RTGH -95/84X Parts.....	28
Obsolete RTG -42P V Parts.....	30
Brand/Model Cross Reference Chart.....	31
Notes Page.....	32
Contact Information.....	BC

* F or Ruud, replace RTG with RUTG

* F or Richmond, replace RTG with RMTG

* F or EcoSense, see cross reference chart, page 31

* F or Paloma, replace RTG with PTG

Tankless accessories

Recess Boxes



Recess Boxes enhance an outdoor installation by protecting the tankless unit from damage and tampering. It also provides additional protection from extreme weather. These boxes come in a grey finish and can be painted by the customer.

- **RTG 20226**

For the RTGH-95X and RTGH-84X
Rough-in Dimensions:
46" High, 16-1/2" Wide, 9-1/2" Deep

- **RTG 20170**

For the RTG-64X, RTG-84X, RTG-95X
and RTG-66X
Rough in Dimensions:
36-1/2" High, 14-3/4" Wide, 8-1/2"
Deep

Pipe Covers



Cosmetic Pipe Covers enhance an indoor or outdoor installation by concealing the pipe beneath the water heater. It provides protection from tampering and weather conditions. These covers come in a grey finish and can be painted by the customer.

- **RTG 20227 (grey)**

For the RTGH-95DV, RTGH-95X, RTGH-84DV, and RTGH-84X

- **RTG 20169D VG (grey)**

For the RTG-64DV, RTG-84DV, RTG-95DV
and RTG-66DV

- **RTG 20217XG (grey)**

For the RTG-95X, RTG-84X, RTG-64X and
RTG-66X

Remote Controls



- **RTG 20006D W**

UMC-117 Main Remote Control

- **RTG 20006D U**

USC1-117 Bath Remote Control

- **RTG 20006D V**

USC2-117 Second Bath Remote
Control

- **RTG 20009-1**

10ft. Thermostat Wire
1 pair 18AWG

Service Valves



- **RTG 20220**

Webstone Service Valves,
includes Relief Valve

- **RTG 20220AB**

Webstone Service Valves,
Clean Brass for California Low
Lead Code, includes Relief Valve

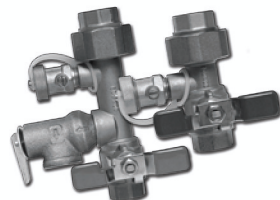

- **RTG 20111-1**

Watts Service Valves,
includes Relief Valve

Relief Valve



- **AP12993C**

Watts Pressure Relief
Valve,
rated at 150PSI.

Flush Kit



Connects easily to Tankless
Isolation Valves. Simple to use.

- **RTG 20124**

Includes: 5-Gallon Bucket,
Submersible Pump, and
two Stainless Steel Hoses

Tankless manifold systems

EZ-Link™ Connect two tankless water heaters

EZ-Link™ Cable

• RTG 20040

Connect two tankless water heaters together in a Manifold*** †

This will allow two heaters to communicate together and operate as a single unit. Perfect for when one tankless is just not enough.

*** Only two units may be connected together with the EZ-Link™ cable.

† Only RTG-2-42, RTG-53 Models, RTG-66 or RTG-74, GT-199 models that have a -1 or greater suffix and all RTG-95 RTG-84, RTG-64, RTGH-84, and RTGH-95 models can be used with the EZ-Link Cable.

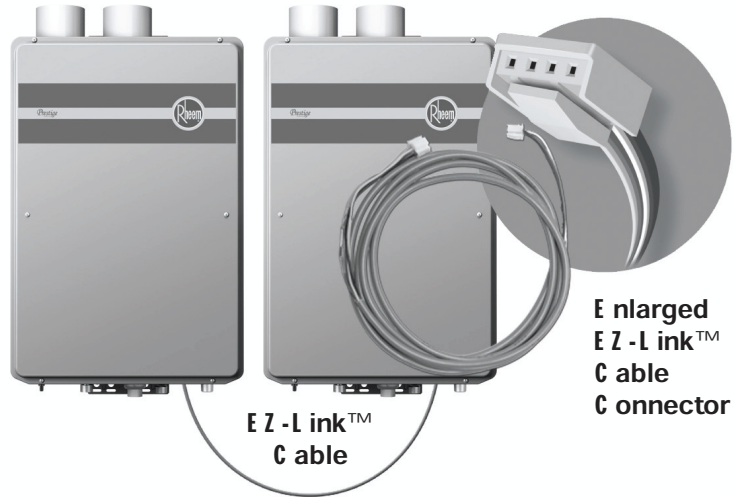

MIC-180 Manifold Controller System Connect Up to 20 Tankless Water Heaters



MIC-180 Manifold Controller

• RTG 20126A

Manifold and control up to 6 tankless models. * Includes installation cabinet for indoor or outdoor applications

MIC-S-180 Manifold Controller Expansion Card

• RTG 20126B

Add on to the MIC-180 for up to 20 units in total. ** Installations of 7 to 20 require this expansion card. Mounts inside the MIC-180 cabinet, includes cables to connect to the MIC-180 board

Replacement Manifold Control Boards

• RTG 20126J - MIC-180

• RTG 20126W - MIC-185

Manifold Control Cables (Type K)

One required for each tankless water heater installed in a manifold. Connects a single tankless water heater to the MIC-180
Note: These cables will not fit the MIC-6

• RTG 20126C

MIC-K-16 16ft Control Cable

• RTG 20126D

MIC-K-32 32ft Control Cable

• RTG 20126E

MIC-K-65 65ft Control Cable



* Only RTG-74 with a -1 or greater suffix on the model number, and all, RTG-2-42, RTG-53, RTG-66 and GT-199 models. Commercial models will be limited to 180°F in a manifold system. Residential models are limited to 140°F.

** This card provides control cable connection points for units 7 - 20 in multi-unit manifold.

MIC-6 Manifold Controller System Connect Up to 6 Tankless Water Heaters

MIC-6 Manifold Controller System

For the RTG-95, RTG-84, and RTG-64 Series models only. This kit will not work on any model manufactured before Jan 2010.

• RTG 20213A

Connect up to 6 tankless water heaters together in a Manifold ‡

This kit mounts inside a single tankless unit and connects to up to 5 additional units for a total of 6

Additional Type Q cables are necessary, listed below.

Manifold Control Cables (Type Q)

One required for each tankless water heater installed in a manifold.

Connects a single tankless water heater to the MIC-6

Note: These cables will not fit the MIC-180

• RTG 20213B - MC-Q-1 1 ft Control Cable

• RTG 20213C - MC-Q-6 6 ft Control Cable

• RTG 20213D - MC-Q-18 18 ft Control Cable

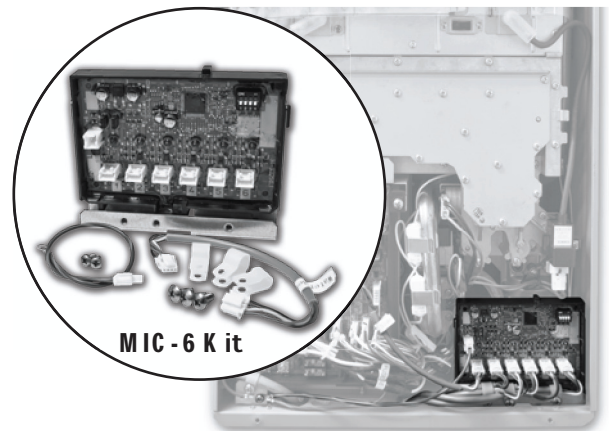

MIC-6 Kit

MIC-6 Installed

Tankless venting

PVC Vent Kits for RTGH-84DV, and RTGH-95DV



Horizontal Vent Termination

- **SP 20286** for 3-Inch PVC
RXGY-G01
- **SP 20285** for 2-Inch PVC
RXGY-G02

11-3/4" Wide, 8" Tall, 2-1/2" Deep
Fits PVC, ABS, piping.
Offers for a clean installation of the intake and exhaust pipes of the condensing tankless water heater.



Horizontal or Vertical Concentric Vent Termination

- **SP 20245** for 3-Inch PVC
RXGY-E03A

11-3/4" Wide, 8" Tall, 2-1/2" Deep
Fits PVC, ABS, piping.
Offers for a clean installation of the intake and exhaust pipes of the condensing tankless water heater.

3"/5" Concentric Vent Kits for RTG-64DV, RTG-84DV, and RTG-95DV



Horizontal Vent Termination Kit by Metal Fab, Inc.

- **RTG 20210**
Contains: 94-Degree Elbow, Long Termination, (1) 12" Wall Plates, Screws.
For up to 10-inch walls.
Can be extended.
MF3CGPHK1



Vertical Vent Termination Kit by Metal Fab, Inc.

- **RTG 20211**
Contains: Storm Collar, 6/12 to 12/12 Pitched Cone Flashing, Vertical Termination with Rain Cap
Does not include vertical vent pipe.
MF3CGVK1

Direct Vent Kits for RTG-66DV and RTG-53DV



Horizontal Vent Termination Kit by Metal Fab, Inc.

- **RTG 20147-1**
Contains: Appliance Adapter, a 94-Degree Elbow, Long Termination, (1) 12" Wall Plates, Screws.
For up to 10-inch walls.
Can be extended.
MF3CGPHK



Vertical Vent Termination Kit by Metal Fab, Inc.

- **RTG 20184**
Contains: Appliance Adapter with Integrated Condensate Collector, Condensate Drain Tube, Storm Collar, 6/12 to 12/12 Pitched Cone Flashing, Vertical Termination with Rain Cap
Does not include vertical vent pipe.
MF3CGVK

Tankless venting

3"/5" Concentric Tankless Venting by Metal Fab, Inc.

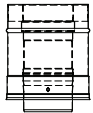

6" Vent Length
• RTG 20151W
5.66' overall length
MF3CG6

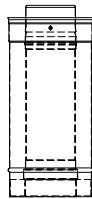

12" Vent Length
• RTG 20151R
11.66' overall length
MF3CG12

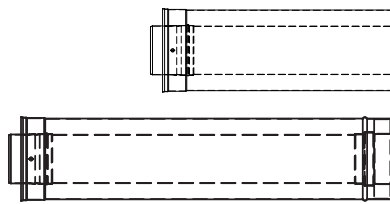

24" Vent Length
• RTG 20151C -1
23.66' overall length
MF3CG24

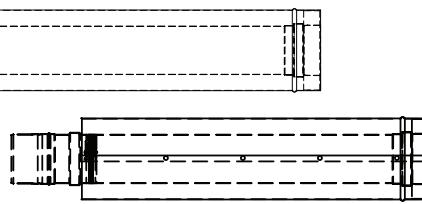

36" Vent Length
• RTG 20151D -1
35.66' overall length
MF3CG36

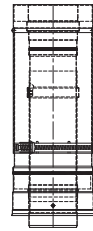

Adjustable Vent Length
• RTG 20151E -1
7.5' to 22' overall length
MF3GVL22

Adjustable Vent Length
• RTG 20222
13' to 20' overall length
MF3CGVAL20

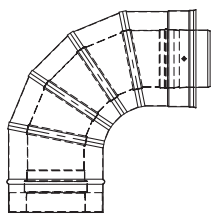

90-Degree Elbow
• RTG 20151A -1
8.1" rise - 8.1" run
MF3CG90L

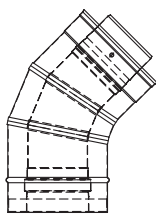

45-Degree Elbow
• RTG 20151B -1
8.6" rise - 3" run
MF3CG45L

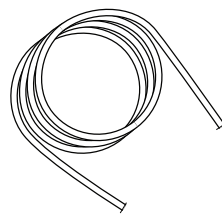

Silicone Condensate Drain Tube Kit
• RTG 20150A
6' high temperature silicone tube, 2 clamps, 2 wire ties, instructions

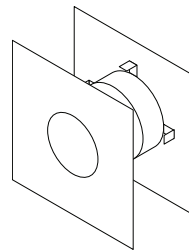

Wall Thimble
• RTG 20151X
12" Square
Up to 8" Deep Wall
MF3CGWPK

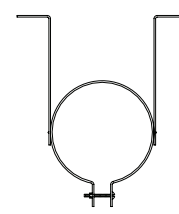

Wall Hanger
• RTG 20151H
2-point pivot mounting
MF3CGWH1

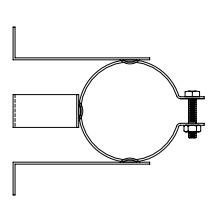

Wall Support
• RTG 20151G
3-point mounting
MF3CGWS1

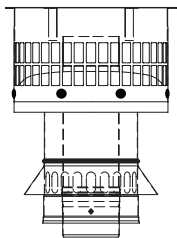

Vertical Cap Termination
• RTG 20151P
12" overall height
MF3CGRVT



Storm Collar
• RTG 20151M -1
split ring galvanized
MF3CGSC

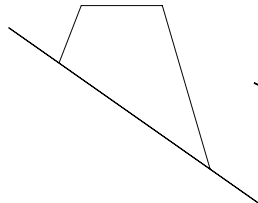

6/12 to 12/12 Roof Flashing
• RTG 20151L -1
15" square base galvanized
MF3CGF-12

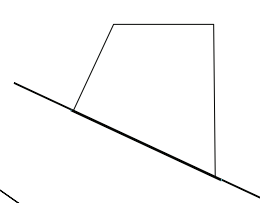

2/12 to 5/12 Roof Flashing
• RTG 20151K -1
15" square base galvanized
MF3CGF

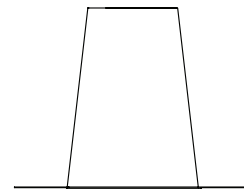

Tall Cone Roof Flashing
• RTG 20151J -1
12" square base galvanized
MF3CGFT

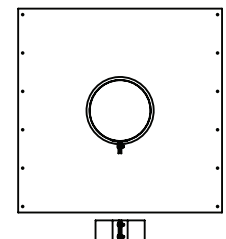

Support Plate
• RTG 20151T
17" square base support/fire stop
MF3CGPS

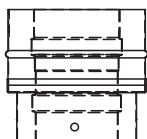

Appliance Adapter
• RTG 20144-3
Fits RTG-66 or 53DV
5" overall length
MF3CGPA

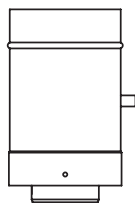

Condensate Drain
• RTG 20151S
horizontal and vertical
8.6' overall length
MF3CGVDS

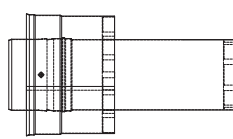

Horizontal Termination
• RTG 20128-2
Short for 4" inch wall
horizontal only
MF3CGPHT

The components listed on this page are manufactured by Metal Fab, Inc. and are not compatible with venting components manufactured by Heat-Fab listed in previous versions the Tankless Parts and Accessories Catalog. Make no attempt to use venting components manufactured by different companies on a single installation.

A limited number of 3' and 4' single wall venting as well as various Heat-Fab components are available, please contact Customer Service for details.

Parts for 53DV series

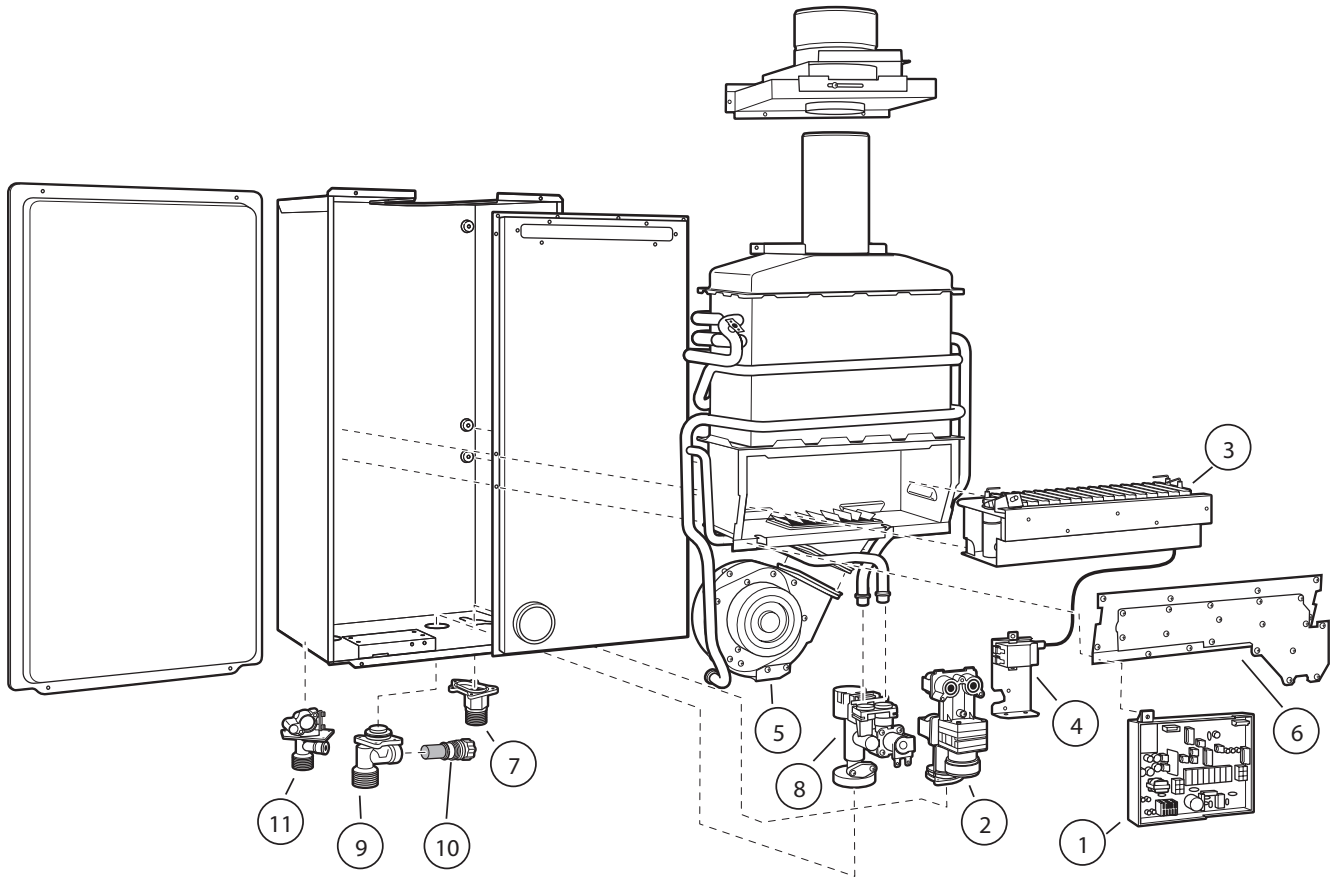

Rheem Part #	Description	RTG-53DV
Sea-Level Program Chip		
RTG20074FN	Program Chip - 0-3280 LP	•
RTG20074FS	Program Chip - 0-3280 NAT	•
High Altitude Program Chips - 3281 - 6560 Feet		
RTG20074FP	Program Chip - 3281-6560 LP	•
RTG20074FT	Program Chip - 3281-6560 NAT	•

Chips for installations above 6560 ft are not available for the 53DV Model

Parts for 53DV series

Ref #	Rheem Part #	Description	RTG-53DV
1	RTG20074DU	Control Board	•
	RTG20006CS	Control Board Fuse (5A)	•
	RTG20074EE	Power Line Fuse (3A)	•
2	RTG20074AH	Gas Valve LP	•
	RTG20074GH	Gas Valve NAT	•
3	RTG20074AS	Burner Assembly LP	•
3	RTG20074AT	Burner Assembly NAT	•
	RTG20074DR	Flame Rod Wire - White	•
	RTG20074DS	Flame Rod Wire - Red	•
4	RTG20074DM	Ignitor Coil	•
	RTG20074DN	Flame Rod	•
	RTG20074DL	Ignitor Electrode	•
5	RTG20074DB	Fan Assembly	•
6	RTG20074BA	Burner Manifold	•
8	RTG20074BT	Water Control Valve	•
	RTG20006AR	Inlet Thermistor - White	•
	RTG20006BB	Outlet Thermistor - Black	•
	RTG20006BC	Heat Exchanger Thermistor - Yellow	•
	RTG20074CY	Ambient Thermistor - Blue	•
9	RTG20006AL	Water Inlet Connector 3/4	•
10	RTG20006AS	Inlet Water Filter	•
11	RTG20074CE	Hot Outlet Connector	•
	RTG20006AW	Drain Relief Valve	•
	RTG20074AA	Mounting Brackets	•
	RTG20074EH	Gas Shut Off Valve 3/4	•
	RTG20074GJ	Gas Inlet Connector 3/4 LP	•
	RTG20074GK	Gas Inlet Connector 3/4 NAT	•
	RTG20074Y	Mounting Brackets	•
	RTG20006CW	Door Screw	•
	RTG20006CZ	Chassis Screw	•
	RTG20074AA	Mounting Brackets	•
	RTG20074EH	Gas Shut Off Valve 3/4	•
	RTG20186	Replacement Screw Kit	•
	RTG20206	Replacement O-Ring Kit	•

Accessories

Remote Controls	RTG20006DW UMC-117 Main Remote Control
	RTG20006DU USC1-117 Bath Remote Control
	RTG20006DV USC2-117 Second Bath Remote Control
Pipe Cover	RTG20063DV Pipe Cover
Service Valves	RTG20111-1 Tankless Service Valve Kit with Relief Valve
Relief Valve	AP12993C Pressure Relief Valve
EZ-Link™ Cable	RTG20040 6FT EZ-Link™ Cable

For parts not listed, please contact Customer Service 1-800-621-5622

Parts for 53X series

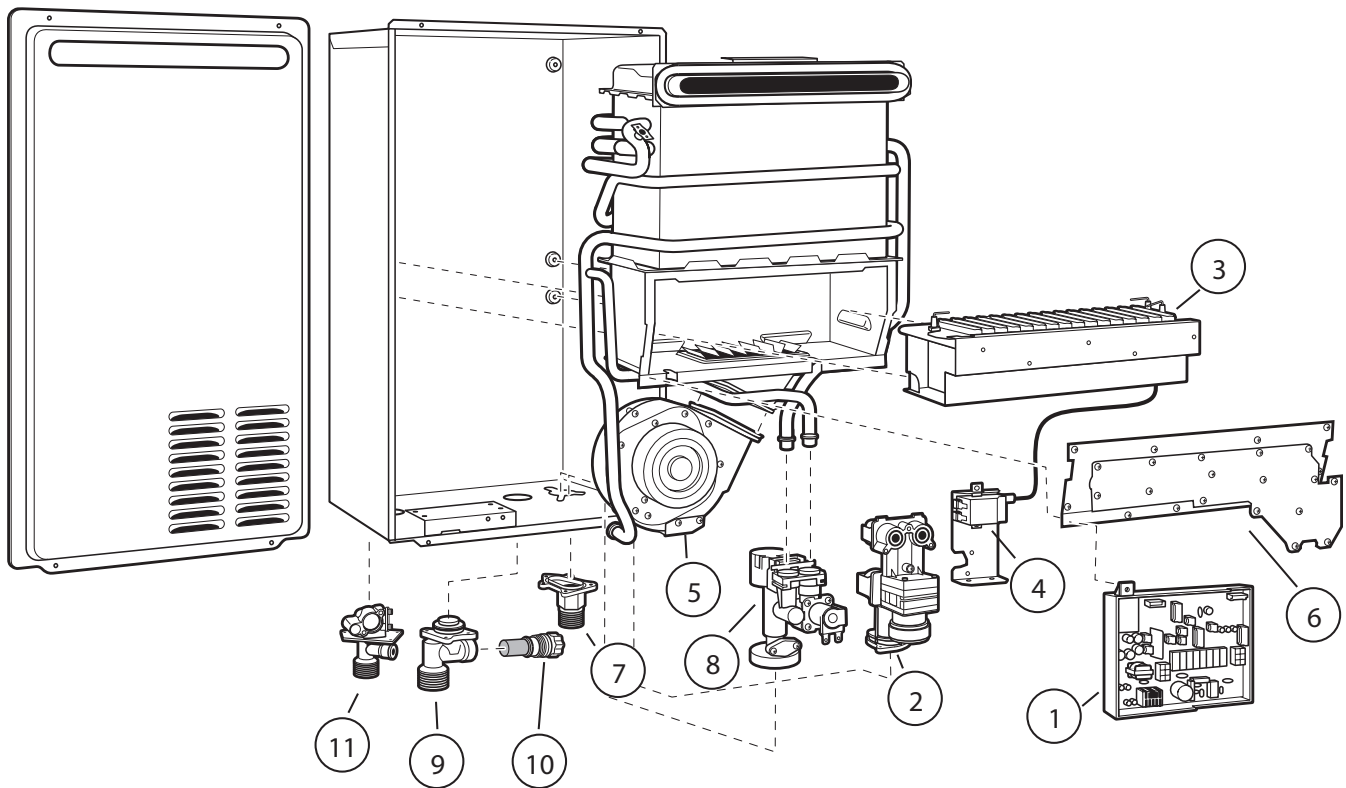

Rheem Part #	Description	RTG-53X
Sea-Level Program Chip		
RTG20074FV	Program Chip - 0-3280 LP	•
RTG20074FY	Program Chip - 0-3280 NAT	•
High Altitude Program Chips - 3281 - 6560 Feet		
RTG20074FW	Program Chip - 3281-6560 LP	•
RTG20074FZ	Program Chip - 3281-6560 NAT	•
Ultra High Altitude Program Chips - 6560 - 9840 Feet		
RTG20074FX	Program Chip - 6560-9840 LP	•
RTG20074GA	Program Chip - 6560-9840 NAT	•

Parts for 53X series

Ref #	Rheem Part #	Description	RTG-53X
1	RTG20074DV	Control Board	•
	RTG20006CS	Control Board Fuse (5A)	•
	RTG20074EE	Power Line Fuse (3A)	•
2	RTG20074AF	Gas Valve LP	•
	RTG20074AG	Gas Valve NAT	•
3	RTG20074AU	Burner Assembly LP	•
3	RTG20074AV	Burner Assembly NAT	•
	RTG20074DR	Flame Rod Wire - White	•
	RTG20074DS	Flame Rod Wire - Red	•
4	RTG20074DM	Ignitor Coil	•
	RTG20074DN	Flame Rod	•
	RTG20074DL	Ignitor Electrode	•
5	RTG20074DC	Fan Assembly	•
	RTG20074DF	Fan Housing	•
6	RTG20074BC	Burner Manifold LP	•
	RTG20074BD	Burner Manifold NAT	•
7	RTG20074GJ	Gas Inlet Connector 3/4 LP	•
	RTG20074GK	Gas Inlet Connector 3/4 NAT	•
8	RTG20074BT	Water Control Valve	•
	RTG20006AR	Inlet Thermistor - White	•
	RTG20006BB	Outlet Thermistor - Black	•
	RTG20006BC	Heat Exchanger Thermistor - Yellow	•
	RTG20006UW	Ambient Thermistor - Blue	•
9	RTG20006AL	Water Inlet Connector 3/4	•
10	RTG20006AS	Inlet Water Filter	•
11	RTG20074CE	Hot Outlet Connector	•
	RTG20006AV	Drain Relief Valve	•
	RTG20074EH	Gas Shut Off Valve 3/4	•
	RTG20074S	Mounting Brackets	•
	RTG20186	Replacement Screw Kit	•
	RTG20206	Replacement O-Ring Kit	•

Accessories

Remote Controls	RTG20006DW UMC-117 Main Remote Control
	RTG20006DU USC1-117 Bath Remote Control
	RTG20006DV USC2-117 Second Bath Remote Control
Pipe Cover	RTG20063PV Pipe Cover (Beige)
Recess Box	RTG20065 Recess Box (Beige)
Service Valves	RTG20111-1 Tankless Service Valve Kit with Relief Valve
Relief Valve	AP12993C Pressure Relief Valve
EZ-Link™ Cable	RTG20040 6FT EZ-Link™ Cable

For parts not listed, please contact Customer Service 1-800-621-5622

Parts for 53PV and 2-42PV series

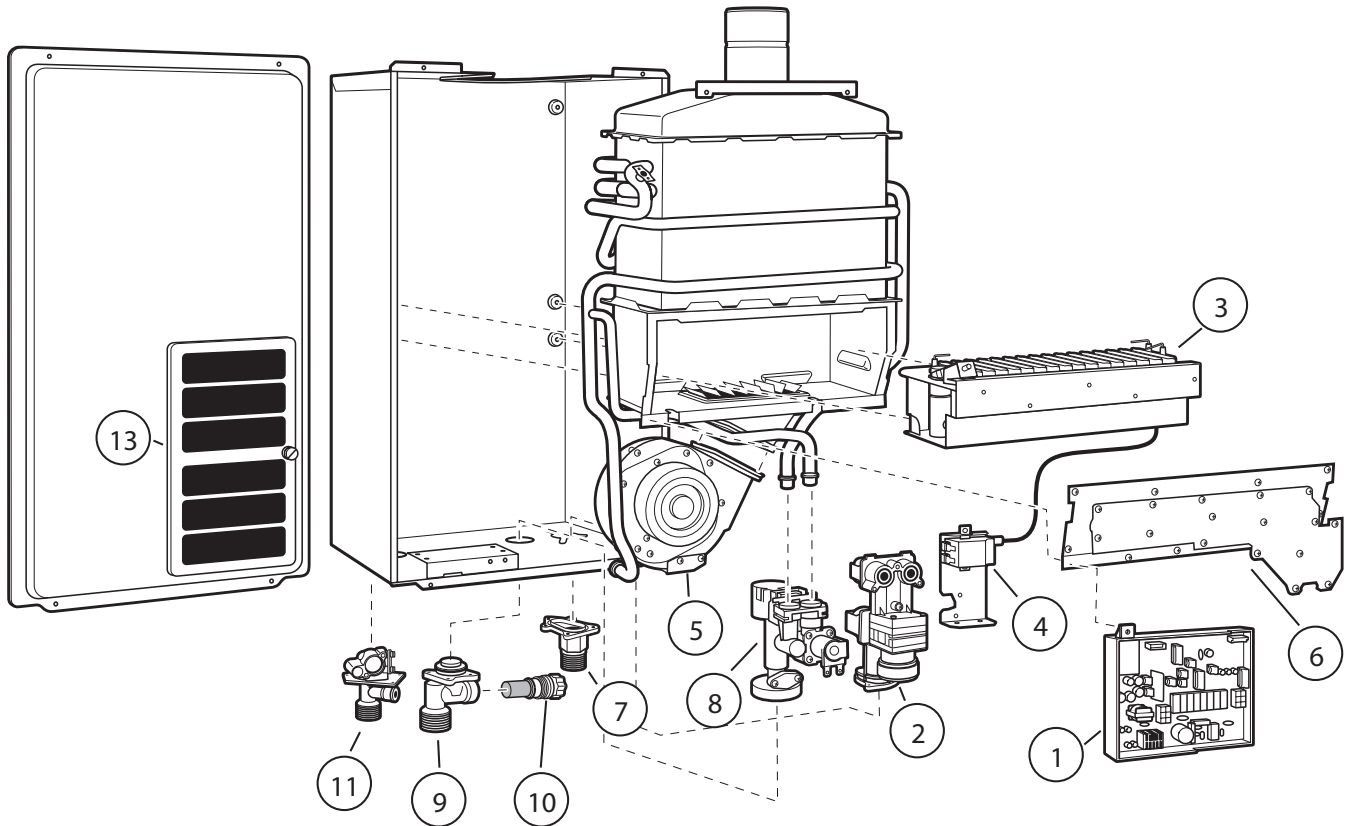

Rheem Part #	Description	RTG2-42PV	RTG-53PV
Sea-Level Program Chip			
RTG20074GB	Program Chip - 0-3280 LP	•	
RTG20074GE	Program Chip - 0-3280 NAT	•	
RTG20074FK	Program Chip - 0-3280 NAT		•
RTG20074FG	Program Chip - 0-3280 LP		•
High Altitude Program Chips - 3281 - 6560 Feet			
RTG20074GC	Program Chip - 3281-6560 LP	•	
RTG20074GF	Program Chip - 3281-6560 NAT	•	
RTG20074FH	Program Chip - 3281-6560 LP		•
RTG20074FL	Program Chip - 3281-6560 NAT		•
Ultra High Altitude Program Chips - 6560 - 9840 Feet			
RTG20074GD	Program Chip - 6560-9840 LP	•	
RTG20074GG	Program Chip - 6560-9840 NAT	•	

Chips for installations above 6560 ft are not available for the 53PV Model

Parts for 53PV and 2-42PV series

Ref #	Rheem Part #	Description	RTG2-42PV	RTG-53PV
1	RTG20074DU	Control Board	•	•
	RTG20006CS	Control Board Fuse (5A)	•	•
	RTG20074EE	Power Line Fuse (3A)	•	•
2	RTG20074AF	Gas Valve - LP		•
2	RTG20074AG	Gas Valve - NAT		•
2	RTG20074AJ	Gas Valve Nat & LP	•	
3	RTG20074AP	Burner Assembly - LP	•	•
3	RTG20074AR	Burner Assembly - NAT	•	•
	RTG20074DL	Ignitor Electrode	•	•
	RTG20074DN	Flame Rod	•	•
	RTG20074DR	Flame Rod Wire - White	•	•
	RTG20074DS	Flame Rod Wire - Red	•	•
4	RTG20074DM	Ignitor Coil	•	•
5	RTG20074DA	Fan Assembly	•	•
6	RTG20074BA	Burner Manifold LP	•	•
6	RTG20074BB	Burner Manifold NAT	•	•
7	RTG20074GJ	Gas Inlet Connector 3/4 LP		•
7	RTG20074GK	Gas Inlet Connector 3/4 NAT		•
7	RTG20074GL	Gas Inlet Connector 1/2	•	
8	RTG20074BT	Water Control Valve	•	•
	RTG20006AR	Inlet Thermistor - White	•	•
	RTG20006BB	Outlet Thermistor - Black	•	•
	RTG20006BC	Heat Exchanger Thermistor - Yellow	•	•
	RTG20074CU	Ambient Thermistor - Blue	•	•
9	RTG20006AL	Water Inlet Connector 3/4	•	•
10	RTG20006AS	Inlet Water Filter	•	•
11	RTG20074CE	Hot Outlet Connector	•	•
	RTG20006AW	Drain Relief Valve	•	•
13	RTG20006C	Door Filter Screen	•	•
	RTG20074Y	Mounting Brackets	•	•
	RTG20074AA	Mounting Brackets	•	•
	RTG20074EJ	Gas Shut Off Valve 1/2	•	
	RTG20074EH	Gas Shut Off Valve 3/4		•
	RTG20186	Replacement Screw Kit	•	•
	RTG20206	Replacement O-Ring Kit	•	•

Accessories

Remote Controls	RTG20006DW UMC-117 Main Remote Control
	RTG20006DU USC1-117 Bath Remote Control
	RTG20006DV USC2-117 Second Bath Remote Control
Pipe Cover	RTG20063PV Pipe Cover (beige)
Service Valves	RTG20111-1 Tankless Service Valve Kit with Relief Valve
Relief Valve	AP12993C Pressure Relief Valve
EZ-Link™ Cable	RTG20040 6FT EZ-Link™ Cable

For parts not listed, please contact Customer Service 1-800-621-5622

Parts for 66DV series

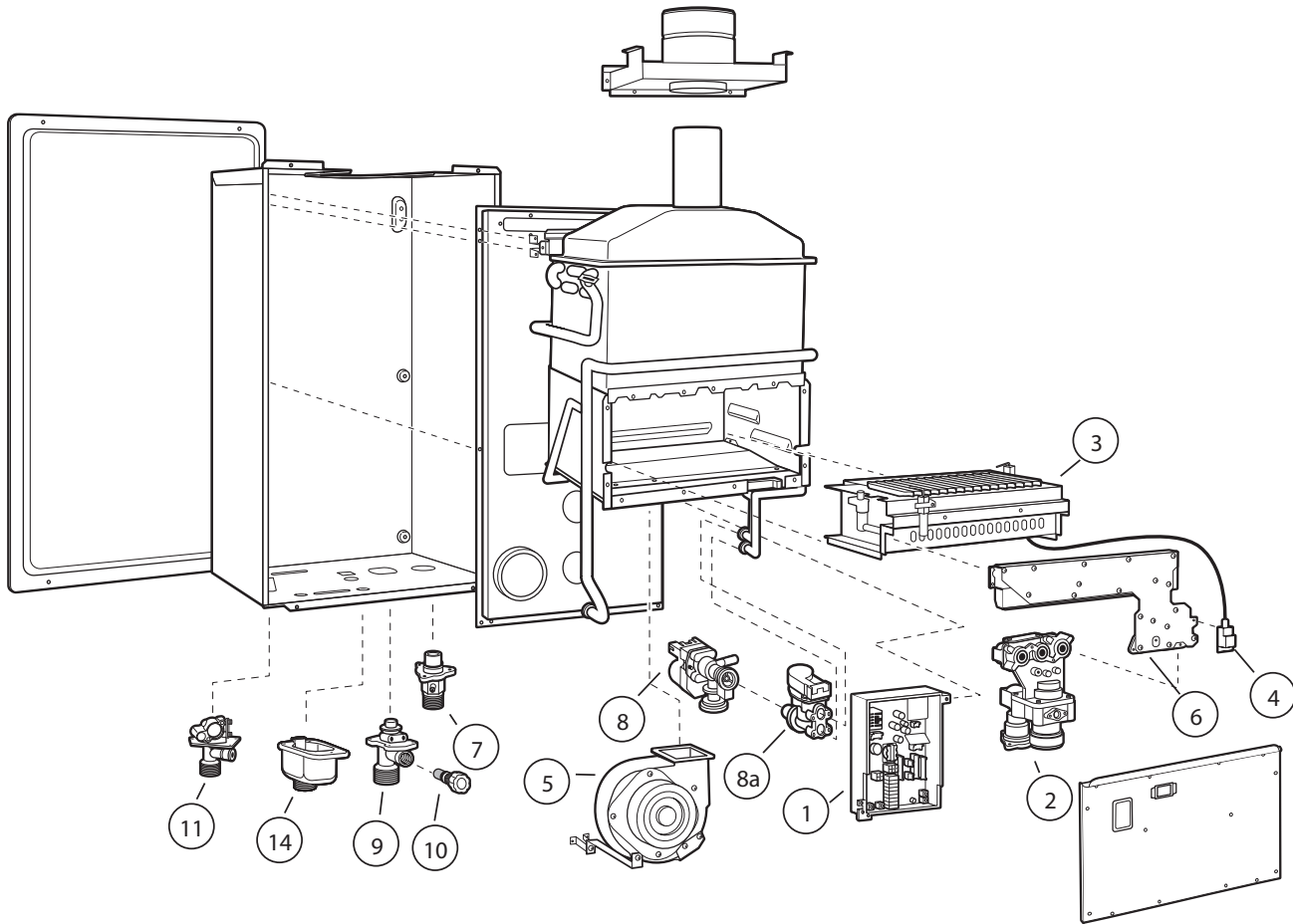

Rheem Part #	Description	RT-66DV	RTG-66DV-1
Fuel Type Program Chips			
RTG20164Y	Program Chip - Natural Gas	•	•
RTG20164X	Program Chip - LP Gas	•	•
Commercial Conversion Kits			
RTG20192A	Natural Gas Commercial Conversion Kit	•	•
RTG20192B	LP Gas Commercial Conversion Kit	•	•

Only fuel specific chips are required for replacement of control boards. Altitude is controlled through dip switch settings and does not require a program chip. See Use and Care for details.

Commercial Conversion Kits allow the 66DV models to operate at a higher water temperature for commercial applications. The kit includes a program chip along with a commercial warranty and instructions. Each heater in a commercial installation would require a kit.

Parts for 66DV series

Ref #	Rheem Part #	Description	RTG-66DV	RTG-66DV-1
1	RTG20164AL	Control Board	•	•
	RTG20074EE	Power Line Fuse (3A)	•	•
	RTG20164P	Heat Exchanger Thermistor - Yellow	•	•
	RTG20164R	Ambient Thermistor - Blue	•	•
	RTG20006AR	Inlet Thermistor - White	•	•
	RTG20006BB	Outlet Thermistor - Black	•	•
2	RTG20164B	Gas Valve - LP	•	•
2	RTG20164A	Gas Valve - NAT	•	•
	RTG20164N	Gas Control Resistor	•	•
7	RTG20164K	Gas Inlet Connector 3/4	•	•
3	RTG20164C	Burner Assembly	•	•
6	RTG20164D	Burner Manifold - LP	•	•
6	RTG20164E	Burner Manifold - NAT	•	•
	RTG20164G	Sensor Orifice - LP	•	•
	RTG20164F	Sensor Orifice - NAT	•	•
4	RTG20164U	Ignitor Coil	•	•
	RTG20164H	Flame Rod	•	•
	RTG20074DL	Ignitor Electrode	•	•
	RTG20074DR	Flame Rod Wire Harness	•	•
5	RTG20164S	Blower Motor	•	•
	RTG20164T	Blower Case	•	•
8	RTG20164L	Water Control Valve	•	•
8a	RTG20164M	Water Bypass Valve	•	•
9	RTG20164J	Water Inlet Connector 3/4	•	•
14	RTG20164Z	Terminal Block Wire Assy	•	•
	RTG20164AA	Remote Control Terminal Block	•	•
10	RTG20164AK	Inlet Water Filter	•	•
11	RTG20074CE	Hot Outlet Connector	•	•
	RTG20006AW	Drain Relief Valve	•	•
	RTG20006CW	Door Screw	•	•
	RTG20006CZ	Chassis Screw	•	•
	RTG20074Y	Mounting Brackets	•	•
	RTG20164AB	Screw Pan FT 4x12	•	•
	RTG20186	Replacement Screw Kit	•	•
	RTG20206	Replacement O-Ring Kit	•	•

Accessories

Remote Controls	RTG20006DW UMC-117 Main Remote Control RTG20006DU USC1-117 Bath Remote Control RTG20006DV USC2-117 Second Bath Remote Control
Pipe Covers	RTG200169DVG Pipe Cover (grey) RTG200169DV Pipe Cover (beige)
Service Valves	RTG20111-1 Tankless Service Valve Kit with Relief Valve
Relief Valve	AP12993C Pressure Relief Valve
EZ-Link™ Cable	RTG20040 6FT EZ-Link™ Cable

Parts for 66X series

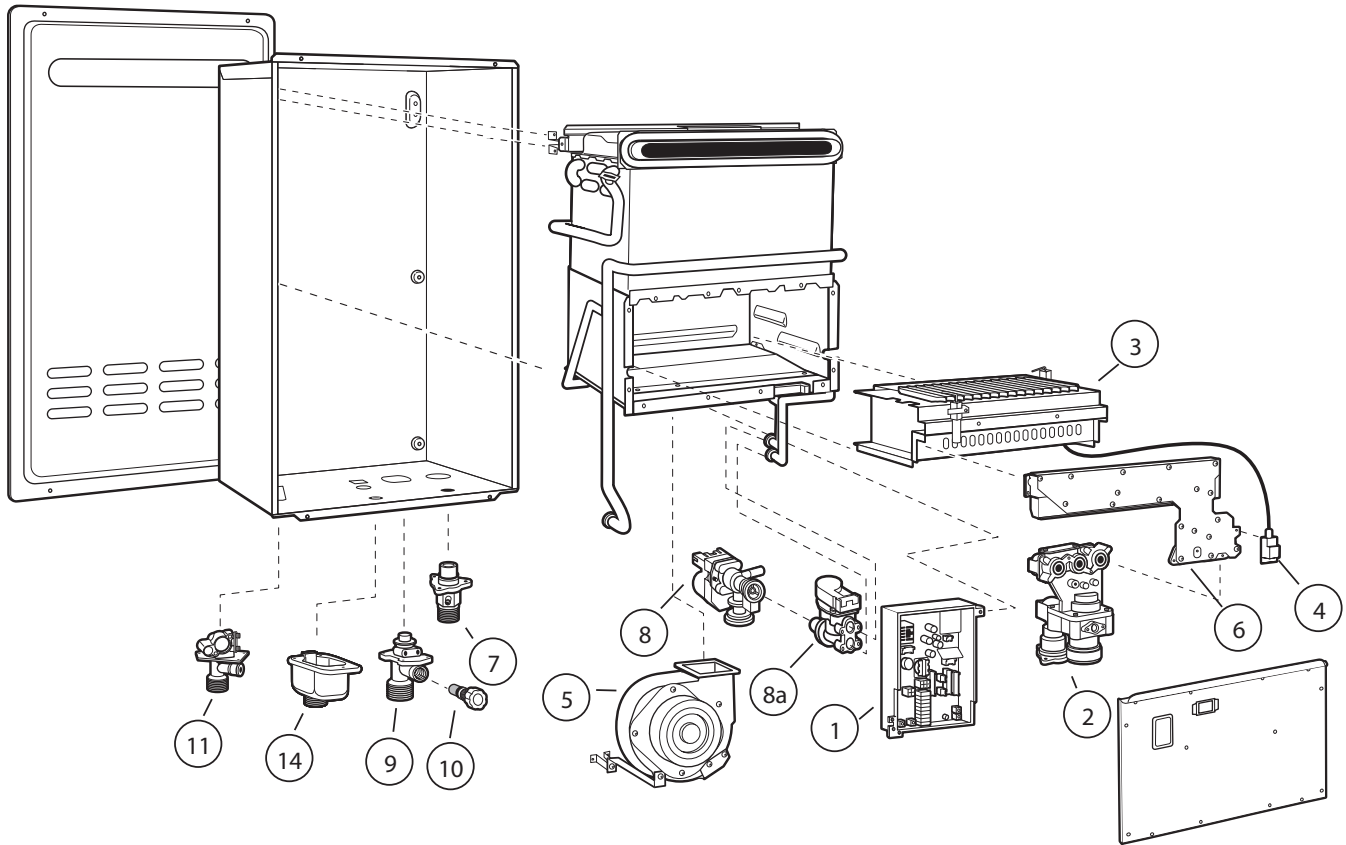

Rheem Part #	Description	RTG-66X	RTG-66X-1
Fuel Type Program Chips			
RTG20164AH	Program Chip - Natural Gas	•	•
RTG20164AJ	Program Chip - LP Gas	•	•
Commercial Conversion Kits			
RTG20192C	Natural Gas Commercial Conversion Kit	•	•
RTG20192D	LP Gas Commercial Conversion Kit	•	•

Only fuel specific chips are required for replacement of control boards. Altitude is controlled through dip switch settings and does not require a program chip. See Use and Care for details.

Commercial Conversion Kits allow the 66X models to operate at a higher water temperature for commercial applications. The kit includes a program chip along with a commercial warranty and instructions. Each heater in a commercial installation would require a kit.

Parts for 66X series

Ref#	RheemPart#	Description	RTG-66X	RTG-66X-1
1	RTG20164AS	Control Board	•	•
	RTG20074EE	Power Line Fuse(3A)	•	•
	RTG20164P	Heat Exchanger Thermistor - Yellow	•	•
	RTG20074CU	Ambient Thermistor - Blue	•	•
	RTG20006AR	Inlet Thermistor - White	•	•
	RTG20006BB	Outlet Thermistor - Black	•	•
2	RTG20164B	Gas Valve - NAT and LP	•	•
	RTG20164N	Gas Control Resistor	•	•
7	RTG20164K	Gas Inlet Connector 3/4	•	•
3	RTG20164AC	Burner Assembly	•	•
6	RTG20164AE	Burner Manifold-LP	•	•
6	RTG20164AD	Burner Manifold-NAT	•	•
4	RTG20164U	Ignitor Coil	•	•
	RTG20164H	Flame Rod	•	•
	RTG20074DL	Ignitor Electrode	•	•
5	RTG20006CC	Blower Motor	•	•
	RTG20164T	Blower Case	•	•
8	RTG20164L	Water Control Valve	•	•
8a	RTG20164M	Water Bypass Valve	•	•
9	RTG20164J	Water Inlet Connector 3/4	•	•
14	RTG20164AA	Remote Control Terminal Block	•	•
	RTG20164Z	Terminal Block Wire Assy	•	•
	RTG20164AB	Screw Pan FT4x12	•	•
10	RTG20164AK	Inlet Water Filter	•	•
11	RTG20074CE	Hot Outlet Connector	•	•
	RTG20006AV	Drain Relief Valve	•	•
	RTG20186	Replacement Screw Kit	•	•
	RTG20206	Replacement O-Ring Kit	•	•

Accessories

Remote Controls

RTG20006DW UMC-117 Main Remote Control
 RTG20006DU USC1-117 Bath Remote Control
 RTG20006DV USC2-117 Second Bath Remote Control

Pipe Covers

RTG200169XG Pipe Cover (grey)

Recess Box

RTG20170 Recess Box (beige)

Service Valves

RTG20111-1 Tankless Service Valve Kit with Relief Valve

Relief Valve

AP12993C Pressure Relief Valve

EZ-Link™ Cable

RTG20040 6FT EZ-Link™ Cable

Parts for 74DV and GT-199DV series

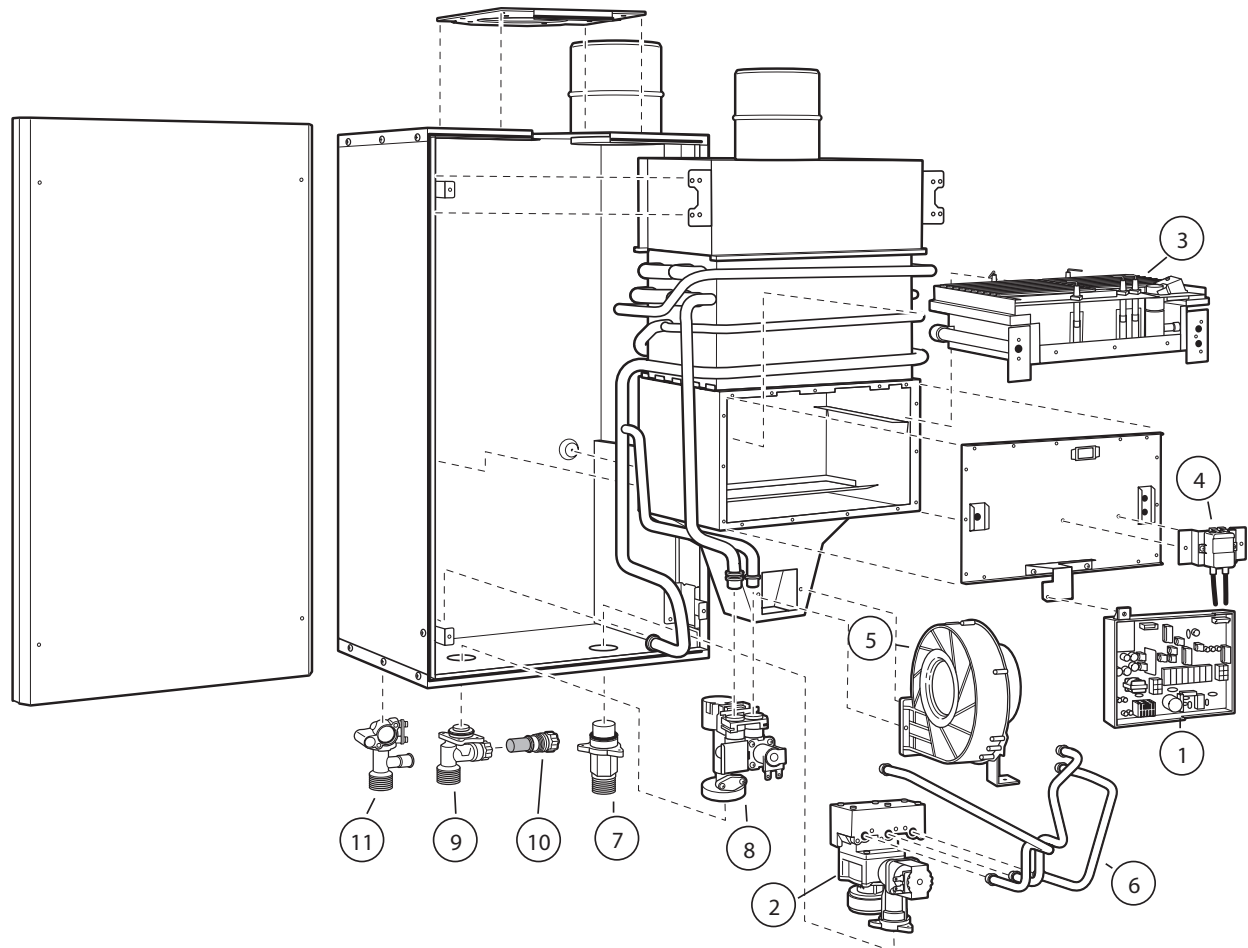

Fuel Type	RTG-74DV	RTG-74DV-1 RTGL74DV-1	RTG-74DV-2 RTGL74DV†	GT-199DV	GT-199DV-1	GT-199DV-2
Sea-Level Program Chip						
Natural	RTG20006MY	RTG20006PU	RTG20006SM	RTG20006PM	RTG20006RA	RTG20006SU
LP	RTG20006MV	RTG20006PX	RTG20006SR	RTG20006PR	RTG20006RD	RTG20006SX
High Altitude Program Chips - 3281 - 6560 Feet						
Natural	RTG20006MZ	RTG20006PV	RTG20006SN	RTG20006PN	RTG20006RB	RTG20006SV
LP	RTG20006MW	RTG20006PY	RTG20006SS	RTG20006PS	RTG20006RE	RTG20006SY
Ultra High Altitude Program Chips - 6560 - 9840 Feet						
Natural	RTG20006NA	RTG20006PW	RTG20006SP	RTG20006PT	RTG20006RF	RTG20006SZ
LP	RTG20006MX	RTG20006PZ	RTG20006ST	RTG20006PP	RTG20006RC	RTG20006SW

Accessories

Remote Controls	RTG20006DW UMC-117 Main Remote Control
	RTG20006DU USC1-117 Bath Remote Control
	RTG20006DV USC2-117 Second Bath Remote Control
Pipe Covers	RTG20037G Pipe Cover (grey)
	RTG20037 Pipe Cover (beige)
Service Valves	RTG20111-1 – Tankless Service Valve Kit with Relief Valve
Relief Valve	AP12993C Pressure Relief Valve
EZ-Link	RTG20040 6FT EZ-Link cable

Parts for 74DV and GT-199DV series

Ref #	Rheem Part #	Description	RTG-74DV	RTG-74DV-1 RTGL74DV-1	RTG-74DV-2 RTGL74DV†	GT-199DV	GT-199DV-1	GT-199DV-2
	RTG20006JC	Control Board	•			•		
1	RTG20006PG	Control Board		•	•		•	•
	RTG20006CS	Control Board Fuse (5A)	•	•	•	•	•	•
	RTG20074EE	Power Line Fuse (3A)	•	•	•	•	•	•
2	RTG20006PA	Gas Valve	•	•	•	•	•	•
3	RTG20006UH	Burner Assembly - NAT / LP		•**	•		•**	•
3	RTG20006VL	Burner Assembly - NAT	•	•*		•	•*	
3	RTG20006VM	Burner Assembly -LP	•	•*		•	•*	
	RTG20006N	Burner Manifold - R LP	•	•		•	•	
	RTG20006P	Burner Manifold - R NAT	•	•		•	•	
	RTG20006T	Burner Manifold - L LP	•	•		•	•	
	RTG20006U	Burner Manifold - L NAT	•	•		•	•	
	RTG20006UL	Burner Manifold - R NAT			•			•
	RTG20006UM	Burner Manifold - R LP			•			•
	RTG20006UR	Burner Manifold - L NAT			•			•
	RTG20006US	Burner Manifold - L LP			•			•
4	RTG20006AA	Ignitor Coil	•	•		•	•	
4	RTG20006UT	Ignitor Coil			•			•
	RTG20006AC	Flame Rod	•	•		•	•	
	RTG20006AD	Ignitor Electrode	•	•	•	•	•	•
	RTG20006UU	Flame Rod			•			•
5	RTG20006CC	Fan Assembly	•	•	•	•	•	•
	RTG20006AR	Inlet Thermistor - White	•	•	•	•	•	•
	RTG20006BB	Outlet Thermistor - Black	•	•	•	•	•	•
	RTG20006BC	Heat Exchanger Thermistor - Yellow	•	•	•	•	•	•
	RTG20006BV	Ambient Thermistor - Blue	•	•	•	•	•	•
	RTG20006CB	Transformer (120v to 100v)	•	•		•	•	
7	RTG20006AN	Gas Inlet Connector 3/4	•	•	•	•	•	•
8	RTG20006AU	Water Control Valve	•					
8	RTG20006JA	Water Control Valve		•	•	•	•	•
9	RTG20006AL	Water Inlet Connector 3/4	•	•	•	•	•	•
10	RTG20006AS	Inlet Water Filter	•	•	•	•	•	•
11	RTG20006AF	Hot Outlet Connector	•	•	•	•	•	•
	RTG20006AW	Drain Relief Valve	•	•	•	•	•	•
	RTG20006VD	Mounting Brackets	•	•	•	•	•	•
	RTG20186	Replacement Screw Kit	•	•	•	•	•	•
	RTG20206	Replacement O-Ring Kit	•	•	•	•	•	•

* If Serial Number is 0906 or earlier

** If Serial Number is 1006 or newer

† The RTGL and ECO models that do not have a suffix, such as a -1 or -2, are equivalent to the RTG -2 Series and utilize the same parts. RTGL and ECO models with a suffix, such as -1, are equivalent to the models with a like suffix.

Parts for 74X and GT-199X series

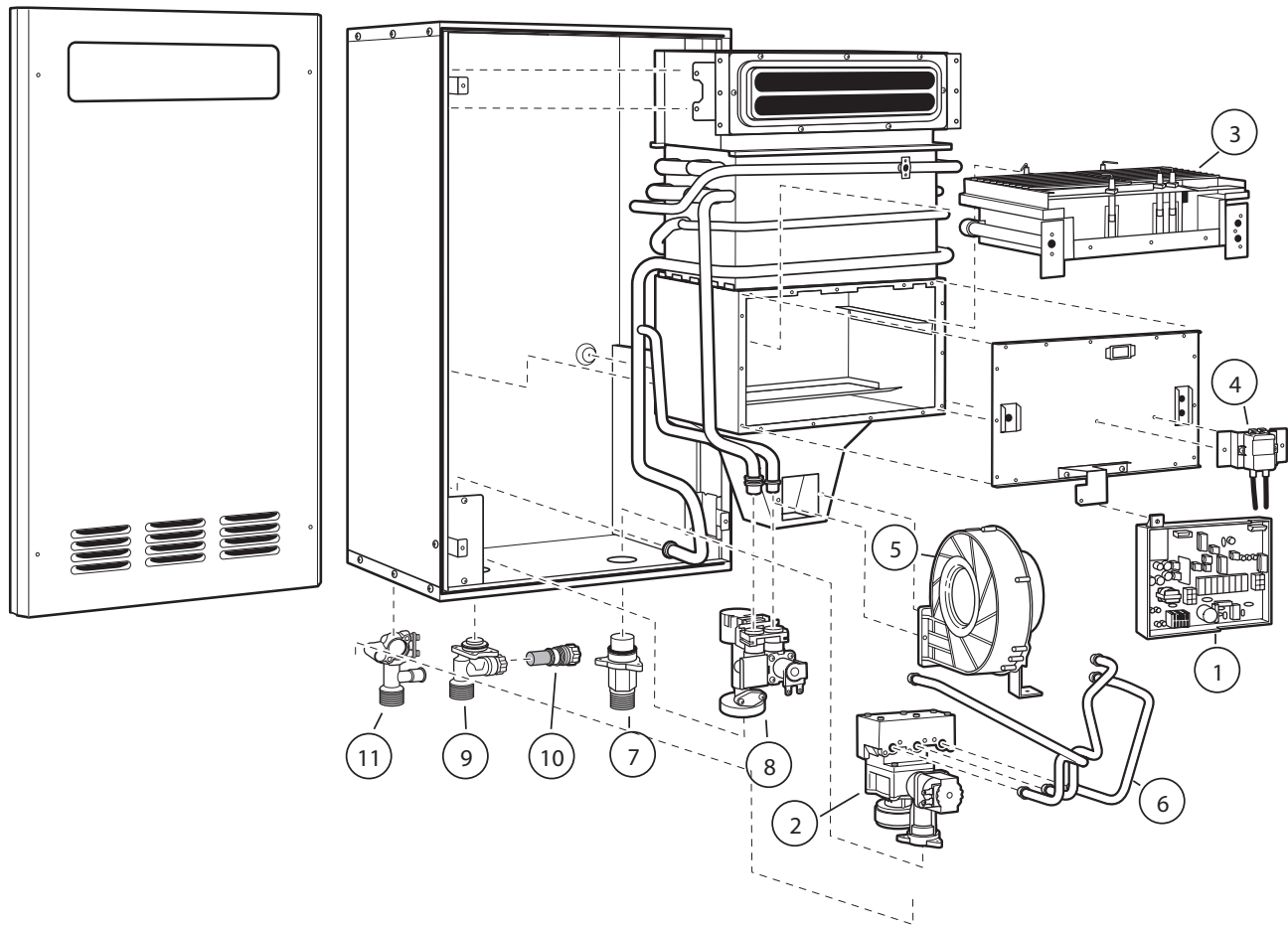

Fuel Type	RTG-74X	RTG-74X-1 RTGL74X-1	RTG-74X-2 RTGL74X†	GT-199X	GT-199X-1	GT-199X-2
Sea-Level Program Chip						
Natural	RTG20006EN	RTG20006RV	RTG20006TN	RTG20006JL	RTG20006SB	RTG20006TV
LP	RTG20006EM	RTG20006RY	RTG20006TS	RTG20006JK	RTG20006SE	RTG20006TY
High Altitude Program Chips - 3281 - 6560 Feet						
Natural	RTG20006EK	RTG20006RW	RTG20006TP	RTG20006JN	RTG20006SC	RTG20006TW
LP	RTG20006EH	RTG20006RZ	RTG20006TT	RTG20006JM	RTG20006SF	RTG20006TZ
Ultra High Altitude Program Chips - 6560 - 9840 Feet						
Natural	RTG20006EL	RTG20006RX	RTG20006TR	RTG20006JR	RTG20006SD	RTG20006TX
LP	RTG20006EJ	RTG20006SA	RTG20006TU	RTG20006JP	RTG20006SG	RTG20006UA

Accessories

Remote Controls	RTG20006DW UMC-117 Main Remote Control RTG20006DU USC1-117 Bath Remote Control RTG20006DV USC2-117 Second Bath Remote Control
Pipe Covers	RTG20037G Pipe Cover (grey) RTG20037 Pipe Cover (beige)
Recess Box	RTG20038 Recess Box (beige)
Service Valves	RTG20220 Tankless Service Valve Kit with Relief Valve
Relief Valve	AP12993C Pressure Relief Valve
EZ-Link™ Cable	RTG20040 6FT EZ-Link™ Cable

Parts for 74X and GT-199X series

Ref #	Rheem Part #	Description	RTG-74X	RTG-74X-1 RTGL74X-1	RTG-74X-2 RTGL74X†	GT-199X	GT-199X-1	GT-199X-2
1	RTG20006JB	Control Board	•			•		
1	RTG20006PF	Control Board		•	•		•	•
	RTG20006CS	Control Board Fuse (5A)	•	•	•	•	•	•
	RTG20074EE	Power Line Fuse (3A)	•	•	•	•	•	•
2	RTG20006PA	Gas Valve	•	•	•	•	•	•
3	RTG20006UE	Burner Assembly - NAT/LP		•**	•		•**	•
3	RTG20006VK	Burner Assembly -NAT/LP	•	•*		•	•*	
	RTG20006L	Burner Manifold - R NAT	•	•		•	•	
	RTG20006M	Burner Manifold - R LP	•	•		•	•	
	RTG20006R	Burner Manifold - L NAT	•	•		•	•	
	RTG20006S	Burner Manifold - L LP	•	•		•	•	
	RTG20006UJ	Burner Manifold - R NAT			•			•
	RTG20006UK	Burner Manifold - R LP			•			•
	RTG20006UN	Burner Manifold - L NAT			•			•
	RTG20006UP	Burner Manifold - L LP			•			•
4	RTG20006AA	Ignitor Coil	•	•		•	•	
	RTG20006AC	Flame Rod	•	•		•	•	
	RTG20006AD	Ignitor Electrode	•	•	•	•	•	•
4	RTG20006UT	Ignitor Coil			•			•
	RTG20006UU	Flame Rod			•			•
5	RTG20006CC	Fan Assembly	•	•	•	•	•	•
	RTG20006AR	Inlet Thermistor - White	•	•	•	•	•	•
	RTG20006BB	Outlet Thermistor - Black	•	•	•	•	•	•
	RTG20006BC	Heat Exchanger Thermistor - Yellow	•	•	•	•	•	•
	RTG20006BV	Ambient Thermistor - Blue	•	•		•	•	
	RTG20006CB	Transformer (120v to 100v)	•	•		•	•	
	RTG20006UV	Ambient Thermistor - Blue			•			•
7	RTG20006AN	Gas Inlet Connector 3/4	•	•	•	•	•	•
8	RTG20006AU	Water Control Valve	•					
8	RTG20006JA	Water Control Valve		•	•	•	•	•
9	RTG20006AL	Water Inlet Connector 3/4	•	•	•	•	•	•
10	RTG20006AS	Inlet Water Filter	•	•	•	•	•	•
11	RTG20006AF	Hot Outlet Connector	•	•	•	•	•	•
	RTG20006AV	Drain Relief Valve	•	•	•	•	•	•
	RTG20006CW	Door Screw				•	•	•
	RTG20006CZ	Chassis Screw				•	•	•
	RTG20006VD	Mounting Brackets	•	•	•	•	•	•
	RTG20186	Replacement Screw Kit	•	•	•	•	•	•
	RTG20206	Replacement O-Ring Kit	•	•	•	•	•	•

* If Serial Number is 0906 or earlier

** If Serial Number is 1006 or newer

† The RTGL and ECO models that do not have a suffix, such as a -1 or -2, are equivalent to the RTG -2 Series and utilize the same parts. RTGL and ECO models with a suffix, such as -1, are equivalent to the models with a like suffix.

Parts for 74PV and GT-199PV series

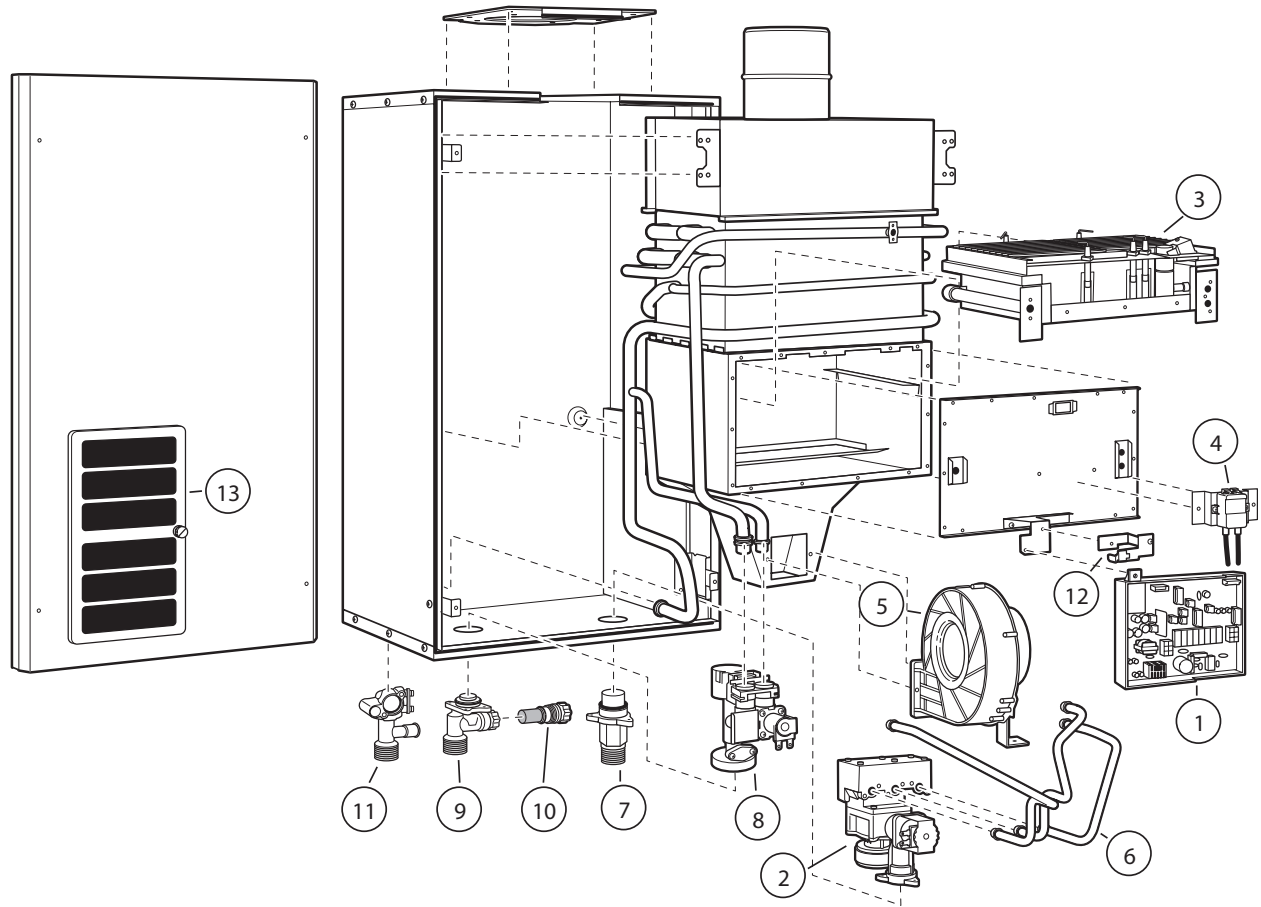

Fuel Type	RTG-74PV	RTG-74PV-1 RTGL74PV-1	RTG-74PV-2 RTGL74PV†	GT-199PV	GT-199PV-1	GT-199PV-2
Sea-Level Program Chip						
Natural	RTG20006DG	RTG20006RG	RTG20006TA	RTG20006JE	RTG20006RN	RTG20006TG
LP	RTG20006DF-1	RTG20006RK	RTG20006TD	RTG20006JD	RTG20006RS	RTG20006TK
High Altitude Program Chips - 3281 - 6560 Feet						
Natural	RTG20006DM-1	RTG20006RH	RTG20006TB	RTG20006JG	RTG20006RP	RTG20006TH
LP	RTG20006DK-1	RTG20006RL	RTG20006TE	RTG20006JF	RTG20006RT	RTG20006TL
Ultra High Altitude Program Chips - 6560 - 9840 Feet						
Natural	RTG20006DN-1	RTG20006RJ	RTG20006TC	RTG20006JJ	RTG20006RR	RTG20006TJ
LP	RTG20006DL-1	RTG20006RM	RTG20006TF	RTG20006JH	RTG20006RU	RTG20006TM

Accessories

Remote Controls	RTG20006DW UMC-117 Main Remote Control RTG20006DU USC1-117 Bath Remote Control RTG20006DV USC2-117 Second Bath Remote Control
Pipe Covers	RTG20037G Pipe Cover (grey) RTG20037 Pipe Cover (beige)
Service Valves	RTG20220 Tankless Service Valve Kit with Relief Valve
Relief Valve	AP12993C Pressure Relief Valve
EZ-Link™ Cable	RTG20040 6FT EZ-Link™ Cable

Parts for 74PV and GT-199PV series

Ref #	Rheem Part #	Description	RTG-74PV	RTG-74PV-1 RTGL74PV-1	RTG-74PV-2 RTGL74PV†	GT-199PV	GT-199PV-1	GT-199PV-2
1	RTG20006JC	Control Board	•			•		
1	RTG20006PG	Control Board		•	•		•	•
	RTG20006CS	Control Board Fuse (5A)	•	•	•	•	•	•
	RTG20074EE	Power Line Fuse (3A)	•	•	•	•	•	•
2	RTG20006PA	Gas Valve	•	•	•	•	•	•
3	RTG20006UF	Burner Assembly - NAT/LP		•**	• (NAT)		•**	• (NAT)
3	RTG20006UG	Burner Assembly -LP			• (LP)			• (LP)
3	RTG20006VJ	Burner Assembly -NAT/LP	•	•*		•	•*	
	RTG20006N	Burner Manifold - R LP	•	•		•	•	
	RTG20006P	Burner Manifold - R NAT	•	•		•	•	
	RTG20006T	Burner Manifold - L LP	•	•		•	•	
	RTG20006U	Burner Manifold - L NAT	•	•		•	•	
	RTG20006UL	Burner Manifold - R NAT			•			•
	RTG20006UM	Burner Manifold - R LP			•			•
	RTG20006UR	Burner Manifold - L NAT			•			•
	RTG20006US	Burner Manifold - L LP			•			•
4	RTG20006AA	Ignitor Coil	•	•		•	•	
4	RTG20006UT	Ignitor Coil			•			•
	RTG20006AC	Flame Rod	•	•		•	•	
	RTG20006AD	Ignitor Electrode	•	•	•	•	•	•
	RTG20006UU	Flame Rod			•			•
5	RTG20006CC	Fan Assembly	•	•	•	•	•	•
	RTG20006AR	Inlet Thermistor - White	•	•	•	•	•	•
	RTG20006BB	Outlet Thermistor - Black	•	•	•	•	•	•
	RTG20006BC	Heat Exchanger Thermistor - Yellow	•	•	•	•	•	•
	RTG20006BV	Ambient Thermistor - Blue	•	•		•	•	
	RTG20006CB	Transformer (120v to 100v)	•	•		•	•	
	RTG20006UW	Ambient Thermistor - Blue			•			•
7	RTG20006AN	Gas Inlet Connector 3/4	•	•	•	•	•	•
8	RTG20006AU	Water Control Valve	•					
8	RTG20006JA	Water Control Valve		•	•	•	•	•
9	RTG20006AL	Water Inlet Connector 3/4	•	•	•	•	•	•
10	RTG20006AS	Inlet Water Filter	•	•	•	•	•	•
11	RTG20006AF	Hot Outlet Connector	•	•	•	•	•	•
	RTG20006AW	Drain Relief Valve	•	•	•	•	•	•
12	RTG20006CK	Door Switch	•	•	•	•	•	•
13	RTG20006C	Door Filter Screen	•	•	•	•	•	•
	RTG20006VD	Mounting Brackets	•	•	•	•	•	•
	RTG20186	Replacement Screw Kit	•	•	•	•	•	•
	RTG20206	Replacement O-Ring Kit	•	•	•	•	•	•

* If Serial Number is 0906 or earlier

** If Serial Number is 1006 or newer

† The RTGL and ECO models that do not have a suffix, such as a -1 or -2, are equivalent to the RTG -2 Series and utilize the same parts. RTGL and ECO models with a suffix, such as -1, are equivalent to the models with a like suffix.

Parts for RTG-64DV, RTG-84DV, RTG-95DV series

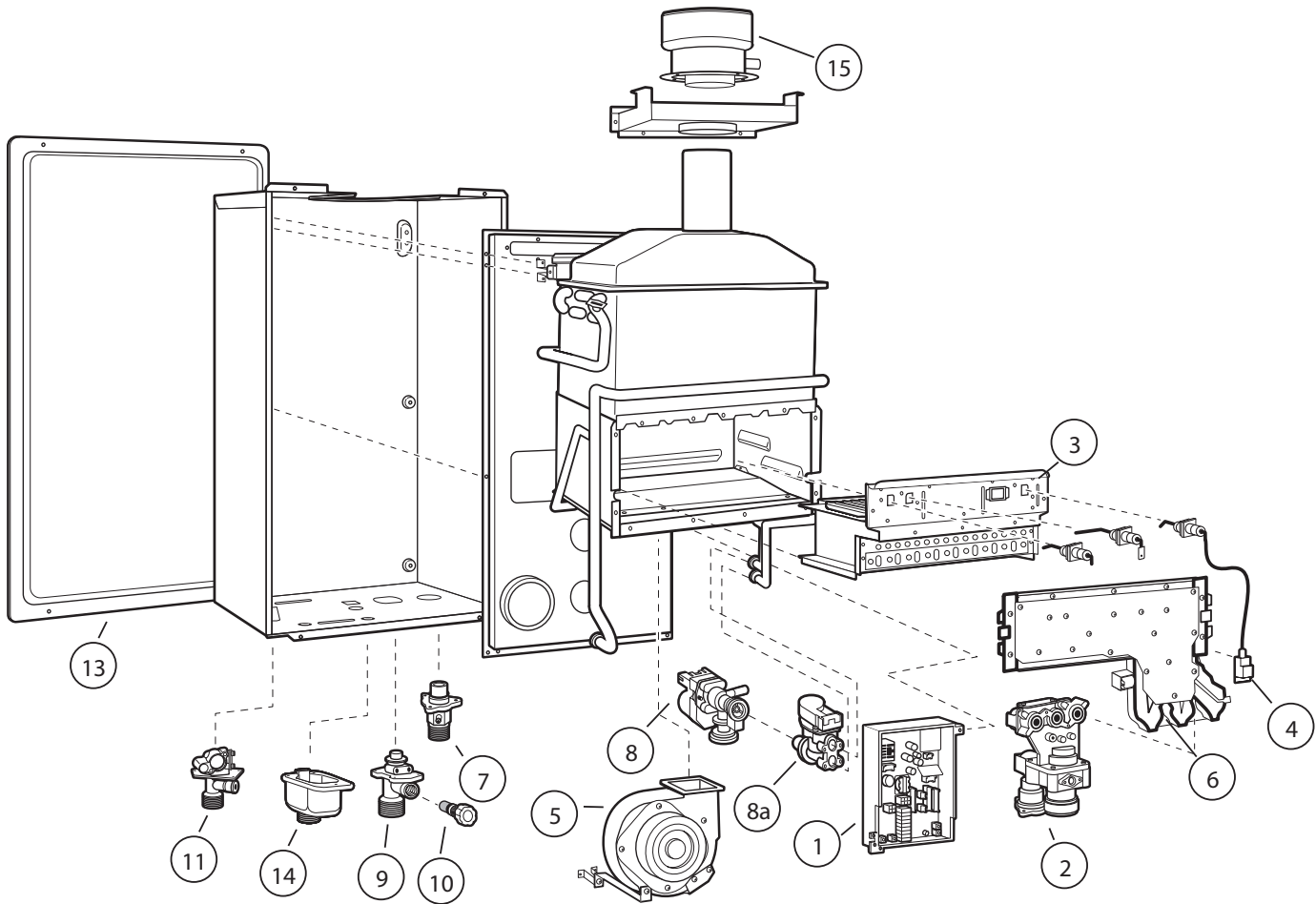

Rheem Part #	Description	RTG-64DV	RTG-84DV	RTG-95DV
Program Chip				
RTG20212S	Natural Gas Program Chip			•
RTG20212T	LP Gas Program Chip			•
RTG20212AL	Natural Gas Program Chip		•	
RTG20212AM	LP Gas Program Chip		•	
RTG20212AV	Natural Gas Program Chip	•		
RTG20212AW	LP Gas Program Chip	•		
Commercial Conversion Kits				
RTG20214A	Natural Gas Commercial Conversion Kit			•
RTG20214B	LP Gas Commercial Conversion Kit			•
RTG20216A	Natural Gas Commercial Conversion Kit		•	
RTG20216B	LP Gas Commercial Conversion Kit		•	

Parts for RTG-64DV, RTG-84DV, RTG-95DV series

Ref #	Rheem Part #	Description	RTG-64DV	RTG-84DV	RTG-95DV
1	RTG20212R	Control Board	•	•	•
	RTG20164R	Thermistor (Blue)	•	•	•
	RTG20164P	Thermistor Assy	•	•	•
	RTG20006AR	Inlet Thermistor - White	•	•	•
	RTG20006BB	Outlet Thermistor - Black	•	•	•
2	RTG20212C	Gas Valve Assy	•	•	•
3	RTG20212D	Burner Assembly	•	•	•
6	RTG20212E	Burner Manifold - NAT	•	•	•
6	RTG20212F	Burner Manifold - LP	•	•	•
	RTG20212G	Flame Rod "FL" (Right)	•	•	•
	RTG20212J	Gas Control Resister	•	•	•
	RTG20212H	Flame Rod "Sensor" (Left)	•	•	•
	RTG20212N	Flame Rod Wire Harness	•	•	•
	RTG20212P	Flame Rod Connector	•	•	•
4	RTG20164U	Ignitor Coil	•	•	•
	RTG20212M	Igniter Rod (Right)	•	•	•
5	RTG20212K	Blower Motor	•	•	•
	RTG20212L	Blower Case	•	•	•
7	RTG20164K	Gas Inlet Connector 3/4	•	•	•
8	RTG20164L	Water Control Valve	•	•	•
8a	RTG20164M	Water Bypass Valve	•	•	•
9	RTG20164J	Water Inlet Connector 3/4	•	•	•
11	RTG20074CE	Hot Water Outlet Connector 3/4	•	•	•
14	RTG20212U	Remote Control Terminal	•	•	•
	RTG20164AA	Remote Control Terminal Block	•	•	•
	RTG20006AW	Drain Relief Valve	•	•	•
	RTG20212A	Top Mounting Bracket	•	•	•
	RTG20212B	Bottom Moutning Bracker	•	•	•
	RTG20164AB	Screw Pan FT 4X12	•	•	•
10	RTG20164AK	Inlet Water Filter	•	•	•
13	RTG20212BA	Front Cover - No Labels or Branding	•	•	•
15	RTG20212BB	Concentric Vent Connector Assembly	•	•	•

Accessories

Remote Controls	RTG20006DW UMC-117 Main Remote Control
	RTG20006DU USC1-117 Bath Remote Control
	RTG20006DV USC2-117 Second Bath Remote Control
Pipe Covers	RTG20169DVG Pipe Cover (grey)
Recess Box	RTG20170 Recess Box (beige)
Service Valves	RTG20220 Tankless Service Valve Kit with Relief Valve
Relief Valve	AP12993C Pressure Relief Valve
EZ-Link™ Cable	RTG20040 6FT EZ-Link™ Cable

See Page 3 for Manifold Controller Information

See Page 4 for Venting

Parts for RTG-64X, RTG-84X, RTG-95X series

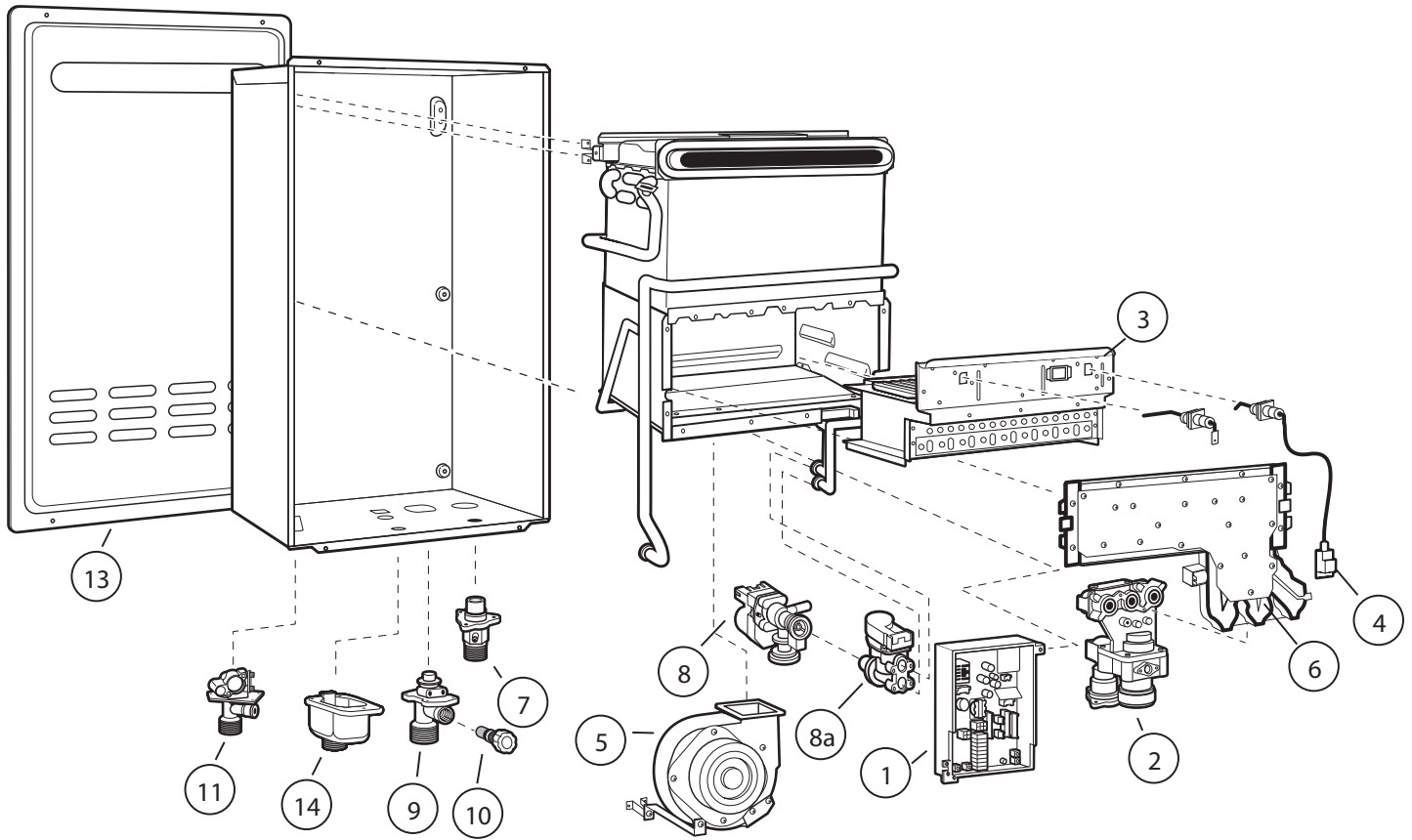

Rheem Part #	Description	RTG-64X	RTG-84X	RTG-95X
Program Chip				
RTG20212AE	Natural Gas Program Chip			•
RTG20212AH	LP Gas Program Chip			•
RTG20212AN	Natural Gas Program Chip		•	
RTG20212AP	LP Gas Program Chip		•	
RTG20212AX	Natural Gas Program Chip	•		
RTG20212AY	LP Gas Program Chip	•		
Commercial Conversion Kits				
RTG20214C	Natural Gas Commercial Conversion Kit			•
RTG20214D	LP Gas Commercial Conversion Kit			•
RTG20216C	Natural Gas Commercial Conversion Kit		•	
RTG20216D	LP Gas Commercial Conversion Kit		•	

Parts for RTG-64X, RTG-84X, RTG-95X series

Ref #	Rheem Part #	Description	RTG-64X	RTG-84X	RTG-95X
1	RTG20212AD	Control Board	•	•	•
	RTG20164P	Thermistor Assy	•	•	•
	RTG20006BB	Outlet Thermistor - Black	•	•	•
	RTG20006AR	Inlet Thermistor - White	•	•	•
	RTG20006UW	Ambient Thermistor - Blue	•	•	•
2	RTG20212V	Gas Valve Assy	•	•	•
	RTG20212J	Gas Control Resister	•	•	•
	RTG20212W	Burner Assembly	•	•	•
3	RTG20212G	Flame Rod "FL" (Right)	•	•	•
	RTG20212M	Igniter Rod (Right)	•	•	•
	RTG20212P	Flame Rod Connector	•	•	•
	RTG20164U	Ignitor Coil	•	•	•
5	RTG20212AB	Blower Motor	•	•	•
	RTG20212AC	Blower Case	•	•	•
6	RTG20212X	Burner Manifold - NAT	•	•	•
	RTG20212F	Burner Manifold - LP	•	•	•
7	RTG20164K	Gas Inlet Connector 3/4	•	•	•
8	RTG20164L	Water Control Valve	•	•	•
8a	RTG20164M	Water Bypass Valve	•	•	•
9	RTG20164J	Water Inlet Connector 3/4	•	•	•
	RTG20006AV	Drain Relief Valve	•	•	•
11	RTG20074CE	Hot Water Outlet Connector 3/4	•	•	•
	RTG20212U	Remote Control Terminal	•	•	•
	RTG20164AA	Remote Control Terminal Block	•	•	•
	RTG20164AB	Screw Pan FT 4X12	•	•	•
10	RTG20164AK	Inlet Water Filter	•	•	•
13	RTG20212AZ	Front Cover - No Labels or Branding	•	•	•

Accessories

Remote Controls	RTG20006DW UMC-117 Main Remote Control
	RTG20006DU USC1-117 Bath Remote Control
	RTG20006DV USC2-117 Second Bath Remote Control
Pipe Covers	RTG20217XG Pipe Cover (grey)
Recess Box	RTG20170 Recess Box (beige)
Service Valves	RTG20111-1 Tankless Service Valve Kit with Relief Valve
Relief Valve	AP12993C Pressure Relief Valve
EZ-Link™ Cable	RTG20040 6FT EZ-Link™ Cable

See Page 3 for Manifold Controller Information

Parts for RTGH-84DV, RTGH-95DV series

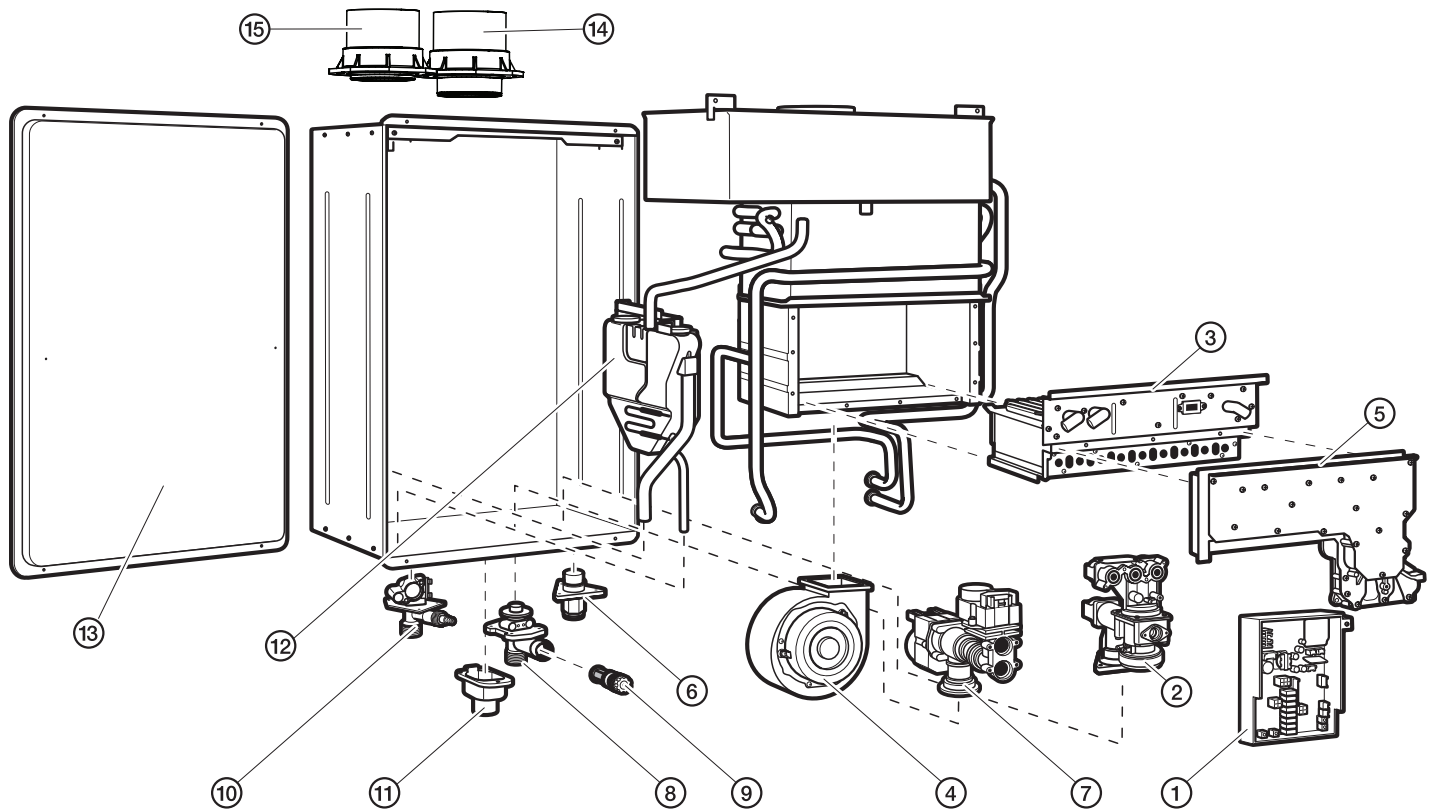

Rheem Part #	Description	RTGH-84DV	RTGH-95DV
Program Chip			
RTG20228T	Natural Gas Program Chip	•	
RTG20228U	LP Gas Program Chip	•	
RTG20228N	Natural Gas Program Chip		•
RTG20228P	LP Gas Program Chip		•
Commercial Conversion Kits			
RTG20225A	Natural Gas Commercial Conversion Kit	•	
RTG20225B	LP Gas Commercial Conversion Kit	•	
RTG20224A	Natural Gas Commercial Conversion Kit		•
RTG20224B	LP Gas Commercial Conversion Kit		•

Accessories

Venting	SP20286 (RXGY-G01) 3-Inch Horizontal Termination Kit
	SP20285 (RXGY-G02) 2-Inch Horizontal Termination Kit
	SP20245 (RXGY-E02) 3-Inch Concentric Horiz/Vertontal Termination Kit
Remote Controls	RTG20006DW UMC-117 Main Remote Control
	RTG20006DU USC1-117 Bath Remote Control
	RTG20006DV USC2-117 Second Bath Remote Control

Parts for RTGH-84DV, RTGH-95DV series

Ref #	Rheem Part #	Description	RTGH-84DV	RTGH-95DV
1	RTG20223P	Control Board	•	•
	RTG20223D	Inlet Thermistor - White	•	•
	RTG20223G	Heat Exchanger Thermistor - Green	•	•
	RTG20223H	Outlet Thermistor - Red	•	•
	RTG20223J	Ambient Thermistor - Blue	•	•
	RTG20223L	Thermostat Assembly	•	•
	RTG20223W	Thermistor Wiring Harness	•	•
2	RTG20212V	Gas Control Valve	•	•
	RTG20223V	Gas Control Wiring Harness	•	•
3	RTG20212D	Burner Assembly	•	•
	RTG20164U	Igniter Coil	•	•
	RTG20212M	Igniter Rod (IG)	•	•
4	RTG20212K	Blower Motor	•	•
	RTG20223K	Blower Case	•	•
5	RTG20212F	Burner Manifold LP	•	•
5	RTG20212X	Burner Manifold NAT	•	•
	RTG20212G	Flame Rod FL-1	•	•
	RTG20212P	Flame Rod Wire	•	•
	RTG20223C	Flame Rod FL-2	•	•
	RTG20223M	Flame Rod Wire No.S	•	•
6	RTG20164K	Gas Inlet Connector 3/4	•	•
7	RTG20223E	Water Control Body	•	•
	RTG20164M	Bypass Assembly	•	•
8	RTG20164J	Water Inlet Connector 3/4	•	•
10	RTG20074CE	Hot Water Outlet Connector 3/4	•	•
11	RTG20164AA	Remote Control Terminal Block	•	•
	RTG20212U	Remote Control Terminal	•	•
12	RTG20223F	Neutralization Replacement Kit	•	•
13	RTG20223B	Front Cover - No Labels or Branding	•	•
14	RTG20223Y	Exhaust Vent Outlet Connector - PVC	•	•
15	RTG20223X	Air Intake Inlet Connector - PVC	•	•

Accessories

Pipe Covers	RTG20227 Pipe Cover (grey)
Service Valves	RTG20220 Tankless Service Valve Kit with Relief Valve RTG20220AB Tankless Service Valve Kit with Relief Valve - California Code
Relief Valve	AP12993C Pressure Relief Valve
EZ-Link™ Cable	RTG20040 6FT EZ-Link™ Cable

See Page 3 for Manifold Controller Information

See Page 4 for Vent Termination Kits

Parts for RTGH-84X, RTGH-95X series

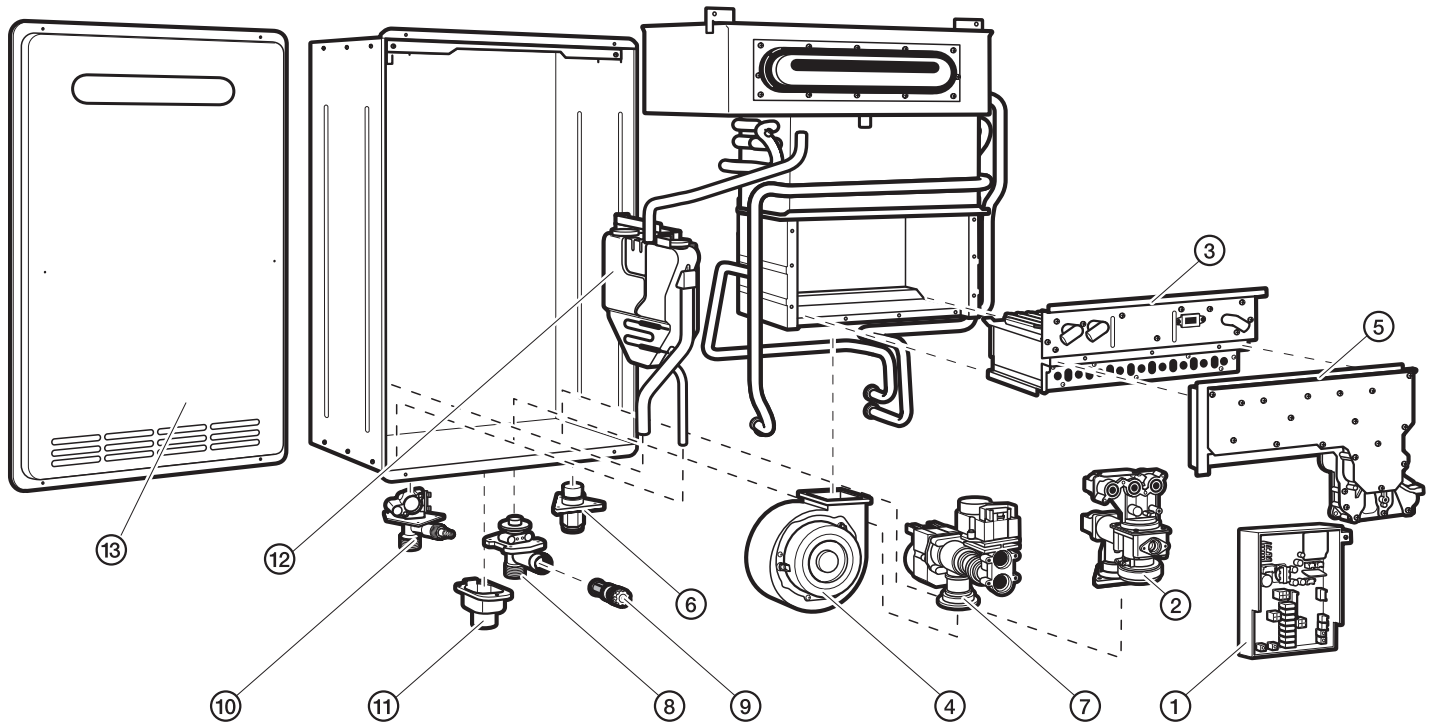

Rheem Part #	Description	RTGH-84X	RTGH-95X
Program Chip			
RTG20228V	Natural Gas Program Chip	•	
RTG20228W	LP Gas Program Chip	•	
RTG20228R	Natural Gas Program Chip		•
RTG20228S	LP Gas Program Chip		•
Commercial Conversion Kits			
RTG20225C	Natural Gas Commercial Conversion Kit	•	
RTG20225D	LP Gas Commercial Conversion Kit	•	
RTG20224C	Natural Gas Commercial Conversion Kit		•
RTG20224D	LP Gas Commercial Conversion Kit		•

Accessories

Remote Controls	RTG20006DW UMC-117 Main Remote Control RTG20006DU USC1-117 Bath Remote Control RTG20006DV USC2-117 Second Bath Remote Control
Pipe Covers	RTG20227 Pipe Cover (grey)
Recess Box	RTG20226 Recess Box (grey)
Service Valves	RTG20220 Tankless Service Valve Kit with Relief Valve RTG20220AB Tankless Service Valve Kit with Relief Valve - California Code
Relief Valve	AP12993C Pressure Relief Valve
EZ-Link™ Cable	RTG20040 6FT EZ-Link™ Cable

Parts for RTGH-84X, RTGH-95X series

Ref #	Rheem Part #	Description	RTGH-84X	RTGH-95X
1	RTG20223N	Control Board	•	•
	RTG20223D	Inlet Thermistor - White	•	•
	RTG20223G	Heat Exchanger Thermistor - Green	•	•
	RTG20223H	Outlet Thermistor - Red	•	•
	RTG20223J	Ambient Thermistor - Blue	•	•
	RTG20223W	Wiring Assy	•	•
2	RTG20212V	Gas Control Valve	•	•
	RTG20223V	Gas Control Wiring Harness	•	•
3	RTG20212W	Burner Assembly	•	•
	RTG20164U	Igniter Coil	•	•
	RTG20212M	Igniter Rod (IG)	•	•
4	RTG20212AB	Blower Motor	•	•
	RTG20212AC	Blower Case	•	•
5	RTG20212F	Burner Manifold LP	•	•
5	RTG20212X	Burner Manifold NAT	•	•
	RTG20212G	Flame Rod FL-1	•	•
	RTG20212P	Flame Rod Wire	•	•
6	RTG20164K	Gas Inlet Connector 3/4	•	•
7	RTG20223E	Water Control Body	•	•
	RTG20164M	Bypass Assembly	•	•
8	RTG20164J	Water Inlet Connector 3/4	•	•
10	RTG20074CE	Hot Water Outlet Connector 3/4	•	•
11	RTG20164AA	Remote Control Terminal	•	•
	RTG20212U	Remote Control Terminal	•	•
12	RTG20223F	Neutralization Kit Set	•	•
13	RTG20223A	Front Cover - No Labels or Branding	•	•

See Page 3 for Manifold Controller Information

Condensing Tankless Model Cross Reference

Rheem	RUUD	Richmond	EcoSense	Paloma
RTGH-95DVN	RUTGH-95DVN	RMTGH95DVN	ECOH200DVN	PHH-32RDVN
RTGH-95DVP	RUTGH-95DVP	RMTGH95DVP	ECOH200DVP	PHH-32RDVP
RTGH-95XN	RUTGH-95XN	RMTGH95XN	ECOH200XN	PHH-32ROFN
RTGH-95XP	RUTGH-95XP	RMTGH95XP	ECOH200XP	PHH-32ROFP
RTGH-84DVN	RUTGH-84DVN	RMTGH84DVN	ECOH160DVN	PHH-25RDVN
RTGH-84DVP	RUTGH-84DVP	RMTGH84DVP	ECOH160DVP	PHH-25RDVP
RTGH-84XN	RUTGH-84XN	RMTGH84XN	ECOH160XN	PHH-25ROFN
RTGH-84XP	RUTGH-84XP	RMTGH84XP	ECOH160XP	PHH-25ROFP

Mid-Efficiency Tankless Model Cross Reference located on page 31.

Parts for 42PV series (obsolete)

Parts for RTG-42PV First Generation series		
Rheem Part #	Description	RTG-42PV
RTG20000BC	Control Board	•
RTG20000BB	Transformer (120v to 100v)	•
RTG20000BJ	Transformer (Power Supply)	•
RTG20074EE	Power Line Fuse (3A)	•
RTG20000Z	Fuse Board Assembly	•
RTG20000AE	Gas Valve - LP	•
RTG20000AF	Gas Valve - Natural	•
RTG20000AW	Gas Inlet Connector 1/2	•
RTG20000AS	Burner Assembly	•
RTG20000AP	Burner Manifold - LP	•
RTG20000AR	Burner Manifold - Natural	•
RTG20000BF	Ignitor Electrode	•
RTG20000S	High Limit Switch	•
RTG20000X	Flame Rod	•
RTG20000BH	Ignitor Coil	•
RTG20000AH	Fan Assembly with Board	•
RTG20000BG	Water Control Valve	•
RTG20006AS	Inlet Water Filter	•
RTG20000AD	Bypass Pipe	•
RTG20000AX	Water Bypass	•
RTG20000T	Heat Exchanger Thermistor - Yellow	•
RTG20000U	Outlet Thermistor - Black	•
RTG20000V	Inlet Thermistor - White	•
RTG20000BA	Cold Inlet Connector	•
RTG20000AY	Drain Plug	•
RTG20000AZ	Hot Outlet Connector	•
RTG20000AB	Door Filter Screen	•
RTG20000AC	Door Switch	•
RTG20000AU	Display Board	•
RTG20000AV	Display Control Board	•
RTG20000BK	Air Flow Switch	•
RTG20186	Replacement Screw Kit	•
RTG20206	Replacement O-Ring Kit	•

Rheem Part #	Description	RTG-42PV
Sea-Level Program Chip		
RTG20000BD	Program Chip - 0-3280 NAT	•
RTG20000BE	Program Chip - 0-3280 LP	•
High Altitude Program Chips - 3281 - 6560 Feet		
RTG20000AK	Program Chip - 3281-6560 NAT	•
RTG20000AJ	Program Chip - 3281-6560 LP	•
Ultra High Altitude Program Chips - 6560 - 9840 Feet		
RTG20000AM	Program Chip - 6560-9840 NAT	•
RTG20000AL	Program Chip - 6560-9840 LP	•

Tankless Model Cross Reference

Rheem	RUUD	Richmond	EcoSense	Paloma Retail	Paloma
RTG2-42PVN	RUTG2-42PVN	RMTG2-42PVN	NA	PTG2-42PVN	PH-16FISN
RTG2-42PVP	RUTG2-42PVP	RMTG2-42PVP	NA	PTG2-42PVP	PH-16FISP
RTG-53PVN	RUTG-53PVN	RMTG-53PVN	ECO-145PVN*	PTG-53PVN	PH-20RIFSN
RTG-53PVP	RUTG-53PVP	RMTG-53PVP	ECO-141PVP*	PTG-53PVP	PH-20RIFSP
RTG-53XN	RUTG-53XN	RMTG-53XN	ECO-141XN*	PTG-53XN	PH-20ROFN
RTG-53XP	RUTG-53XP	RMTG-53XP	ECO-141XP*	PTG-53XP	PH-20ROFP
RTG-53DVN	RUTG-53DVN	RMTG-53DVN	ECO-141DVN*	PTG-53DVN	PH-20RDVSN
RTG-53DVP	RUTG-53DVP	RMTG-53DVP	ECO-135DVP*	PTG-53DVP	PH-20RDVSP
RTG-66DVN	RUTG-66DVN	RMTG-66DVN	ECO-180DVN*		PH-25RDVSN
RTG-66DVP	RUTG-66DVP	RMTG-66DVP	ECO-180DVP*		PH-25RDVSP
RTG-66XN	RUTG-66XN	RMTG-66XN	ECO-180XN*		PH-25ROFN
RTG-66XP	RUTG-66XP	RMTG-66XP	ECO-180XP*		PH-25ROFP
RTG-74PVN*	RUTG-74PVN*	RMTG-74PVN*		PTG-74PVN*	PH-28RIFSN
RTG-74PVP*	RUTG-74PVP*	RMTG-74PVP*		PTG-74PVP*	PH-28RIFSP
RTG-74XN*	RUTG-74XN*	RMTG-74XN*		PTG-74XN*	PH-28ROFN
RTG-74XP*	RUTG-74XP*	RMTG-74XP*		PTG-74XP*	PH-28ROFP
RTG-74DVN*	RUTG-74DVN*	RMTG-74DVN*		PTG-74DVN*	PH-28RDVSN
RTG-74DVP*	RUTG-74DVP*	RMTG-74DVP*		PTG-74DVP*	PH-28RDVSP
RTGL74PVN**	RUTGL74PVN**	RMTGL74PVN**	ECO200PVN*		
RTGL74PVP**	RUTGL74PVP**	RMTGL74PVP**	ECO200PVP*		
RTGL74XN**	RUTGL74XN**	RMTGL74XN**	ECO200XN*		
RTGL74XP**	RUTGL74XP**	RMTGL74XP**	ECO200XP*		
RTGL74DVN**	RUTGL74DVN**	RMTGL74DVN**	ECO200DVN*		
RTGL74DVP**	RUTGL74DVP**	RMTGL74DVP**	ECO200DVP*		
GT-199PVN*	GT-199PVN*	NA	NA	NA	PH-28CIFSN
GT-199PVP*	GT-199PVP*	NA	NA	NA	PH-28CIFSP
GT-199XN*	GT-199XN*	NA	NA	NA	PH-28COFN
GT-199XP*	GT-199XP*	NA	NA	NA	PH-28COFP
GT-199DVN*	GT-199DVN*	NA	NA	NA	PH-28CDVSN
GT-199DVP*	GT-199DVP*	NA	NA	NA	PH-28CDVSP
RTG-64DVN	RUTG-64DVN	RMTG64DVN	ECO150DVN3		PH2-20RDVSN
RTG-64DVP	RUTG-64DVP	RMTG64DVP	ECO150DVP3		PH2-20RDVSP
RTG-64XN	RUTG-64XN	RMTG64XN	ECO150XN3		PH2-20ROFN
RTG-64XP	RUTG-64XP	RMTG64XP	ECO150XP3		PH2-20ROFN
RTG-84DVN	RUTG-84DVN	RMTG84DVN	ECO180DVN3		PH2-25RDVSN
RTG-84DVP	RUTG-84DVP	RMTG84DVP	ECO180DVP3		PH2-25RDVSP
RTG-84XN	RUTG-84XN	RMTG84XN	ECO180XN3		PH2-25ROFN
RTG-84XP	RUTG-84XP	RMTG84XP	ECO180XP3		PH2-25ROFN
RTG-95DVN	RUTG-95DVN	RMTG95DVN	ECO200DVN3		PH2-28RDVSN
RTG-95DVP	RUTG-95DVP	RMTG95DVP	ECO200DVP3		PH2-28RDVSP
RTG-95XN	RUTG-95XN	RMTG95XN	ECO200XN3		PH2-28ROFN
RTG-95XP	RUTG-95XP	RMTG95XP	ECO200XP3		PH2-28ROFN
RTGH-95DVN	RUTGH-95DVN	RMTGH95DVN	ECO200DVN		PHH-32RDV
RTGH-95DVP	RUTGH-95DVP	RMTGH95DVP	ECO200DVP		PHH-32RDV
RTGH-95XN	RUTGH-95XN	RMTGH95XN	ECO200XN		PHH-32ROF
RTGH-95XP	RUTGH-95XP	RMTGH95XP	ECO200XP		PHH-32ROF
RTGH-84DVN	RUTGH-84DVN	RMTGH84DVN	ECO160DVN		PHH-25RDV
RTGH-84DVP	RUTGH-84DVP	RMTGH84DVP	ECO160DVP		PHH-25RDV
RTGH-84XN	RUTGH-84XN	RMTGH84XN	ECO160XN		PHH-25ROF
RTGH-84XP	RUTGH-84XP	RMTGH84XP	ECO160XP		PHH-25ROF

* Model may have an additional number attached such as a -1 or -2 these are generation designations. Model numbers with no additional number are first generation, models with a -1 are second generation, models with a -2 are third generation, and so on.

**The RTGL and ECO models that do not have a suffix, such as a -1 or -2, are equivalent to the RTG Series -2 models and utilize the same parts as the -2 models. RTGL and ECO models with a -1 suffix are equivalent to the RTG Series -1 models.

Condensing Tankless Model Cross Reference located on page 29.

