

Transmission Structures

<http://waterheatertimer.org/Names-of-parts-on-electric-pole.html>

Fang, S.J.; Roy, S. and Kramer, J. "Transmission Structures"
Structural Engineering Handbook
Ed. Chen Wai-Fah
Boca Raton: CRC Press LLC, 1999

Transmission Structures

15.1 Introduction and Application

Application • Structure Configuration and Material • Constructibility • Maintenance Considerations • Structure Families • State of the Art Review

15.2 Loads on Transmission Structures

General • Calculation of Loads Using NESC Code • Calculation of Loads Using the ASCE Guide • Special Loads • Security Loads • Construction and Maintenance Loads • Loads on Structure • Vertical Loads • Transverse Loads • Longitudinal Loading

15.3 Design of Steel Lattice Tower

Tower Geometry • Analysis and Design Methodology • Allowable Stresses • Connections • Detailing Considerations • Tower Testing

15.4 Transmission Poles

General • Stress Analysis • Tubular Steel Poles • Wood Poles • Concrete Poles • Guyed Poles

15.5 Transmission Tower Foundations

Geotechnical Parameters • Foundation Types—Selection and Design • Anchorage • Construction and Other Considerations • Safety Margins for Foundation Design • Foundation Movements • Foundation Testing • Design Examples

15.6 Defining Terms

References

Shu-jin Fang, Subir Roy, and
Jacob Kramer

Sargent & Lundy, Chicago, IL

15.1 Introduction and Application

Transmission structures support the [phase conductors](#) and shield wires of a transmission line. The structures commonly used on transmission lines are either lattice type or pole type and are shown in [Figure 15.1](#). Lattice structures are usually composed of steel angle sections. Poles can be wood, steel, or concrete. Each structure type can also be self-supporting or guyed. Structures may have one of the three basic configurations: horizontal, vertical, or delta, depending on the arrangement of the phase conductors.

15.1.1 Application

Pole type structures are generally used for [voltages](#) of 345-kV or less, while lattice steel structures can be used for the highest of voltage levels. Wood pole structures can be economically used for relatively shorter spans and lower voltages. In areas with severe climatic loads and/or on higher voltage lines with multiple subconductors per phase, designing wood or concrete structures to meet the large

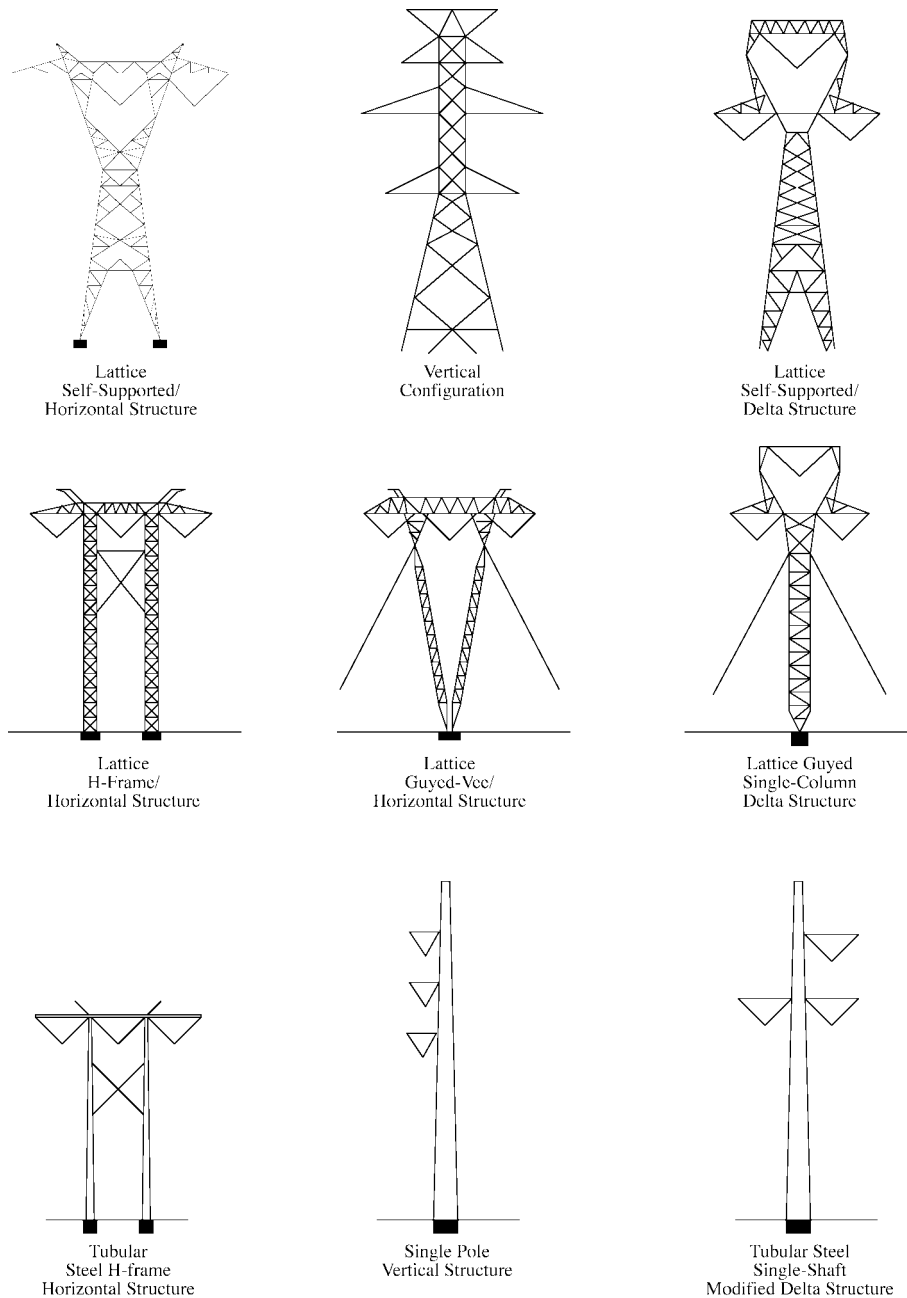

FIGURE 15.1: Transmission line structures.

loads can be uneconomical. In such cases, steel structures become the cost-effective option. Also, if greater **longitudinal loads** are included in the design criteria to cover various unbalanced loading contingencies, H-frame structures are less efficient at withstanding these loads. Steel lattice towers can be designed efficiently for any magnitude or orientation of load. The greater complexity of these towers typically requires that full-scale load tests be performed on new tower types and at least the

tangent tower to ensure that all members and connections have been properly designed and detailed. For guyed structures, it may be necessary to proof-test all anchors during construction to ensure that they meet the required holding capacity.

15.1.2 Structure Configuration and Material

Structure cost usually accounts for 30 to 40% of the total cost of a transmission line. Therefore, selecting an optimum structure becomes an integral part of a cost-effective transmission line design. A structure study usually is performed to determine the most suitable structure configuration and material based on cost, construction, and maintenance considerations and electric and magnetic field effects. Some key factors to consider when evaluating the structure configuration are:

- A horizontal phase configuration usually results in the lowest structure cost.
- If right-of-way costs are high, or the width of the right-of-way is restricted or the line closely parallels other lines, a vertical configuration may be lower in total cost.
- In addition to a wider right-of-way, horizontal configurations generally require more tree clearing than vertical configurations.
- Although vertical configurations are narrower than horizontal configurations, they are also taller, which may be objectionable from an aesthetic point of view.
- Where electric and magnetic field strength is a concern, the phase configuration is considered as a means of reducing these fields. In general, vertical configurations will have lower field strengths at the edge of the right-of-way than horizontal configurations, and delta configurations will have the lowest single-circuit field strengths and a double-circuit with reverse or low-reactance phasing will have the lowest possible field strength.

Selection of the structure type and material depends on the design loads. For a single circuit 230-kV line, costs were estimated for single-pole and H-frame structures in wood, steel, and concrete over a range of design [span lengths](#). For this example, wood H-frames were found to have the lowest installed cost, and a design span of 1000 ft resulted in the lowest cost per mile. As design loads and other parameters change, the relative costs of the various structure types and materials change.

15.1.3 Constructibility

Accessibility for construction of the line should be considered when evaluating structure types. Mountainous terrain or swampy conditions can make access difficult and use of helicopter may become necessary. If permanent access roads are to be built to all structure locations for future maintenance purposes, all sites will be accessible for construction.

To minimize environmental impacts, some lines are constructed without building permanent access roads. Most construction equipment can traverse moderately swampy terrain by use of wide-track vehicles or temporary mats. Transporting concrete for foundations to remote sites, however, increases construction costs.

Steel lattice towers, which are typically set on concrete shaft foundations, would require the most concrete at each tower site. Grillage foundations can also be used for these towers. However, the cost of excavation, backfill and compaction for these foundations is often higher than the cost of a drilled shaft. Unless subsurface conditions are poor, most pole structures can be directly embedded. However, if unguyed pole structures are used at medium to large line angles, it may be necessary to use drilled shaft foundations.

Guyed structures can also create construction difficulties in that a wider area must be accessed at each structure site to install the guys and anchors. Also, careful coordination is required to ensure that all guys are tensioned equally and that the structure is plumb.

Hauling the structure materials to the site must also be considered in evaluating constructibility. Transporting concrete structures, which weigh at least five times as much as other types of structures, will be difficult and will increase the construction cost of the line. Heavier equipment, more trips to transport materials, and more matting or temporary roadwork will be required to handle these heavy poles.

15.1.4 Maintenance Considerations

Maintenance of the line is generally a function of the structure material. Steel and concrete structures should require very little maintenance, although the maintenance requirements for steel structures depends on the type of finish applied. Tubular steel structures are usually galvanized or made of weathering steel. Lattice structures are galvanized. Galvanized or painted structures require periodic inspection and touch-up or reapplication of the finish while weathering steel structures should have relatively low maintenance. Wood structures, however, require more frequent and thorough inspections to evaluate the condition of the poles. Wood structures would also generally require more frequent repair and/or replacement than steel or concrete structures. If the line is in a remote location and lacks permanent access roads, this can be an important consideration in selecting structure material.

15.1.5 Structure Families

Once the basic structure type has been established, a family of structures is designed, based on the line route and the type of terrain it crosses, to accommodate the various loading conditions as economically as possible. The structures consist of tangent, angle, and deadend structures.

Tangent structures are used when the line is straight or has a very small **line angle**, usually not exceeding 3° . The line angle is defined as the deflection angle of the line into adjacent spans. Usually one tangent type design is sufficient where terrain is flat and the span lengths are approximately equal. However, in rolling and mountainous terrain, spans can vary greatly. Some spans, for example, across a long valley, may be considerably larger than the normal span. In such cases, a second tangent design for long spans may prove to be more economical. Tangent structures usually comprise 80 to 90% of the structures in a transmission line.

Angle towers are used where the line changes direction. The point at which the direction change occurs is generally referred to as the point of intersection (P.I.) location. Angle towers are placed at the P.I. locations such that the transverse axis of the cross arm bisects the angle formed by the conductor, thus equalizing the longitudinal pulls of the conductors in the adjacent spans. On lines where large numbers of P.I. locations occur with varying degrees of line angles, it may prove economical to have more than one angle structure design: one for smaller angles and the other for larger angles.

When the line angle exceeds 30° , the usual practice is to use a deadend type design. Deadend structures are designed to resist wire pulls on one side. In addition to their use for large angles, the deadend structures are used as terminal structures or for sectionalizing a long line consisting of tangent structures. Sectionalizing provides a longitudinal strength to the line and is generally recommended every 10 miles. Deadend structures may also be used for resisting **uplift loads**. Alternately, a separate strain structure design with deadend insulator assemblies may prove to be more economical when there is a large number of structures with small line angle subjected to uplift. These structures are not required to resist the deadend wire pull on one side.

15.1.6 State of the Art Review

A major development in the last 20 years has been in the area of new analysis and design tools. These include software packages and design guidelines [12, 6, 3, 21, 17, 14, 9, 8], which have greatly

improved design efficiency and have resulted in more economical structures. A number of these tools have been developed based on test results, and many new tests are ongoing in an effort to refine the current procedures. Another area is the development of the reliability based design concept [6]. This methodology offers a uniform procedure in the industry for calculation of structure loads and strength, and provides a quantified measure of reliability for the design of various transmission line components.

Aside from continued refinements in design and analysis, significant progress has been made in the manufacturing technology in the last two decades. The advance in this area has led to the increasing usage of cold formed shapes, structures with mixed construction such as steel poles with lattice arms or steel towers with FRP components, and prestressed concrete poles [7].

15.2 Loads on Transmission Structures

15.2.1 General

Prevailing practice and most state laws require that transmission lines be designed, as a minimum, to meet the requirements of the current edition of the National Electrical Safety Code (NESC) [5]. NESC's rules for the selection of loads and [overload capacity factors](#) are specified to establish a minimum acceptable level of safety. The ASCE Guide for Electrical Transmission Line Structural Loading (ASCE Guide) [6] provides loading guidelines for extreme ice and wind loads as well as security and safety loads. These guidelines use reliability based procedures and allow the design of transmission line structures to incorporate specified levels of reliability depending on the importance of the structure.

15.2.2 Calculation of Loads Using NESC Code

NESC code [5] recognizes three loading districts for ice and wind loads which are designated as heavy, medium, and light loading. The radial thickness of ice and the wind pressures specified for the loading districts are shown in Table 15.1. Ice build-up is considered only on conductors and [shield wires](#), and is usually ignored on the structure. Ice is assumed to weigh 57 lb/ft³. The wind pressure applies to cylindrical surfaces such as conductors. On the flat surface of a lattice tower member, the wind pressure values are multiplied by a force coefficient of 1.6. Wind force is applied on both the windward and leeward faces of a lattice tower.

TABLE 15.1 Ice, Wind, and Temperature

	Loading districts		
	Heavy	Medium	Light
Radial thickness of ice (in.)	0.50	0.25	0
Horizontal wind pressure (lb/ft ²)	4	4	9
Temperature (°F)	0	+15	+30

NESC also requires structures to be designed for extreme wind loading corresponding to 50 year fastest mile wind speed with no ice loads considered. This provision applies to all structures without conductors, and structures over 60 ft supporting conductors. The extreme wind speed varies from a basic speed of 70 mph to 110 mph in the coastal areas.

In addition, NESC requires that the basic loads be multiplied by overload capacity factors to

determine the design loads on structures. Overload capacity factors make it possible to assign relative importance to the loads instead of using various allowable stresses for different load conditions. Overload capacity factors specified in NESC have a larger value for wood structures than those for steel and prestressed concrete structures. This is due to the wide variation found in wood strengths and the aging effect of wood caused by decay and insect damage. In the 1990 edition, NESC introduced an alternative method, where the same overload factors are used for all the materials but a strength reduction factor is used for wood.

15.2.3 Calculation of Loads Using the ASCE Guide

The ASCE Guide [6] specifies extreme ice and extreme wind loads, based on a 50-year return period, which are assigned a reliability factor of 1. These loads can be increased if an engineer wants to use a higher reliability factor for an important line, for example a long line, or a line which provides the only source of load. The load factors used to increase the ASCE loads for different reliability factors are given in Table 15.2.

TABLE 15.2 Load Factor to Adjust Line Reliability

Line reliability factor, LRF	1	2	4	8
Load return period, RP	50	100	200	400
Corresponding load factor, \bar{a}	1.0	1.15	1.3	1.4

In calculating wind loads, the effects of terrain, structure height, wind gust, and structure shape are included. These effects are explained in detail in the ASCE Guide. ASCE also recommends that the ice loads be combined with a wind load equal to 40% of the extreme wind load.

15.2.4 Special Loads

In addition to the weather related loads, transmission line structures are designed for special loads that consider security and safety aspects of the line. These include security loads for preventing cascading type failures of the structures and construction and maintenance loads that are related to personnel safety.

15.2.5 Security Loads

Longitudinal loads may occur on the structures due to accidental events such as broken conductors, broken insulators, or collapse of an adjacent structure in the line due to an environmental event such as a tornado. Regardless of the triggering event, it is important that a line support structure be designed for a suitable longitudinal loading condition to provide adequate resistance against cascading type failures in which a larger number of structures fail sequentially in the longitudinal direction or parallel to the line. For this reason, longitudinal loadings are sometimes referred to as “anticascading”, “failure containment”, or “security loads”.

There are two basic methods for reducing the risk of cascading failures, depending on the type of structure, and on local conditions and practices. These methods are: (1) design all structures for broken wire loads and (2) install stop structures or guys at specified intervals.

Design for Broken Conductors

Certain types of structures such as square-based lattice towers, 4-guyed structures, and single shaft steel poles have inherent longitudinal strength. For lines using these types of structures, the

recommended practice is to design every structure for one broken conductor. This provides the additional longitudinal strength for preventing cascading failures at a relatively low cost.

Anchor Structures

When single pole wood structures or H-frame structures having low longitudinal strength are used on a line, designing every structure for longitudinal strength can be very expensive. In such cases, stop or anchor structures with adequate longitudinal strength are provided at specific intervals to limit the [cascading effect](#). The Rural Electrification Administration [19] recommends a maximum interval of 5 to 10 miles between structures with adequate longitudinal capacity.

15.2.6 Construction and Maintenance Loads

Construction and maintenance (C&M) loads are, to a large extent, controllable and are directly related to construction and maintenance methods. A detailed discussion on these types of loads is included in the ASCE Loading Guide, and Occupation Safety and Health Act (OSHA) documents. It should be emphasized, however, that workers can be seriously injured as a result of structure overstress during C&M operations; therefore, personnel safety should be a paramount factor when establishing C&M loads. Accordingly, the ASCE Loading Guide recommends that the specified C&M loads be multiplied by a minimum load factor of 1.5 in cases where the loads are “static” and well defined; and by a load factor of 2.0 when the loads are “dynamic”, such as those associated with moving wires during [stringing](#) operations.

15.2.7 Loads on Structure

Loads are calculated on the structures in three directions: vertical, transverse, and longitudinal. The transverse load is perpendicular to the line and the longitudinal loads act parallel to the line.

15.2.8 Vertical Loads

The vertical load on supporting structures consists of the weight of the structure plus the superimposed weight, including all wires, ice coated where specified.

Vertical load of wire V_w in. (lb/ft) is given by the following equations:

$$V_w = \text{wt. of bare wire (lb/ft)} + 1.24(d + I)I \quad (15.1)$$

where

d = diameter of wire (in.)

I = ice thickness (in.)

Vertical wire load on structure (lb)

$$= V_w \times \text{vertical design span} \times \text{load factor} \quad (15.2)$$

Vertical design span is the distance between low points of adjacent spans and is indicated in Figure 15.2.

15.2.9 Transverse Loads

Transverse loads are caused by wind pressure on wires and structure, and the transverse component of the [line tension](#) at angles.

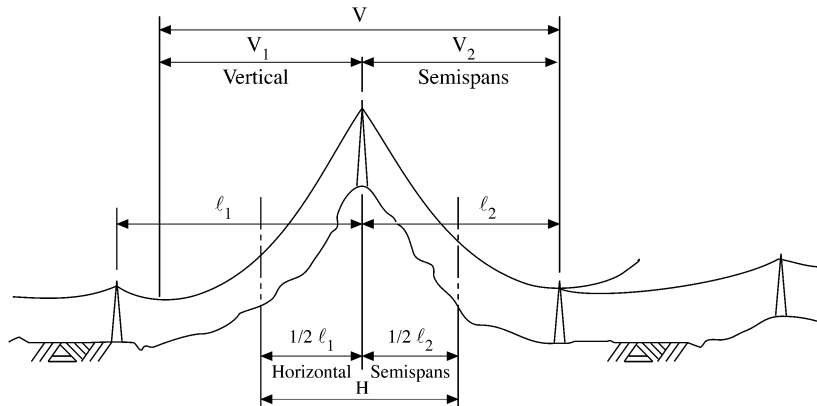

FIGURE 15.2: Vertical and horizontal design spans.

Wind Load on Wires

The transverse load due to wind on the wire is given by the following equations:

$$W_h = p \times d/12 \times \text{Horizontal Span} \times OCF \text{ (without ice)} \quad (15.3)$$

$$= p \times (d + 2I)/12 \times \text{Horizontal Span} \times OCF \text{ (with ice)} \quad (15.4)$$

where

- W_h = transverse wind load on wire in lb
- p = wind pressure in lb/ft²
- d = diameter of wire in in.
- I = radial thickness of ice in in.
- OCF = Overload Capacity Factor

Horizontal span is the distance between midpoints of adjacent spans and is shown in Figure 15.2.

Transverse Load Due to Line Angle

Where a line changes direction, the total transverse load on the structure is the sum of the transverse wind load and the transverse component of the wire tension. The transverse component of the tension may be of significant magnitude, especially for large angle structures. To calculate the total load, a wind direction should be used which will give the maximum resultant load considering the effects on the wires and structure.

The transverse component of wire tension on the structure is given by the following equation:

$$H = 2T \sin \theta/2 \quad (15.5)$$

where

- H = transverse load due to wire tension in pounds
- T = wire tension in pounds
- θ = Line angle in degrees

Wind Load on Structures

In addition to the wire load, structures are subjected to wind loads acting on the exposed areas of the structure. The wind force coefficients on lattice towers depend on shapes of member sections, solidity ratio, angle of incidence of wind (face-on wind or diagonal wind), and shielding. Methods

for calculating wind loads on transmission structures are given in the ASCE Guide as well the NESC code.

15.2.10 Longitudinal Loading

There are several conditions under which a structure is subjected to longitudinal loading:

Deadend Structures—These structures are capable of withstanding the full tension of the conductors and shield wires or combinations thereof, on one side of the structure.

Stringing— Longitudinal load may occur at any one phase or shield wire due to a hang-up in the blocks during stringing. The longitudinal load is taken as the stringing tension for the complete phase (i.e., all subconductors strung simultaneously) or a shield wire. In order to avoid any prestressing of the conductors, stringing tension is typically limited to the minimum tension required to keep the conductor from touching the ground or any obstructions. Based on common practice and according to the IEEE “Guide to the Installation of Overhead Transmission Line Conductors” [4], stringing tension is generally about one-half of the sagging tension. Therefore, the longitudinal stringing load is equal to 50% of the initial, unloaded tension at 60°F.

Longitudinal Unbalanced Load—Longitudinal unbalanced forces can develop at the structures due to various conditions on the line. In rugged terrain, large differentials in adjacent span lengths, combined with inclined spans, could result in significant longitudinal unbalanced load under ice and wind conditions. Non-uniform loading of adjacent spans can also produce longitudinal unbalanced loads. This load is based on an ice shedding condition where ice is dropped from one span and not the adjacent spans. Reference [12] includes a software that is commonly used for calculating unbalanced loads on the structure.

EXAMPLE 15.1: Problem

Determine the wire loads on a small angle structure in accordance with the data given below. Use NESC medium district loading and assume all intact conditions.

Given Data:

Conductor: 954 kcm 45/7 ACSR
Diameter = 1.165 in.
Weight = 1.075 lb/ft
Wire tension for NESC medium loading = 8020 lb

Shield Wire: 3 No.6 Alumoweld
Diameter = 0.349 in.
Weight = 0.1781 lb/ft
Wire tension for NESC medium loading = 2400 lb

Wind Span = 1500 ft
Weight Span = 1800 ft
Line angle = 5°
Insulator weight = 170 lb

Solution

NESC Medium District Loading

4 psf wind, 1/4-in. ice

Ground Wire Iced Diameter = $0.349 + 2 \times 0.25 = 0.849$ in.

Conductor Ice Diameter = $1.165 + 2 \times 0.25 = 1.665$ in.

Overload Capacity Factors for Steel

Transverse Wind = 2.5

Wire Tension = 1.65

Vertical = 1.5

Conductor Loads On Tower

Transverse

Wind = $4 \text{ psf} \times 1.665"/12 \times 1500 \times 2.5 = 2080$ lb

Line Angle = $2 \times 8020 \times \sin 2.5^\circ \times 1.65 = 1150$ lb

Total = 3230 lb

Vertical

Bare Wire = $1.075 \times 1800 \times 1.5 = 2910$ lb

Ice = $\{1.24(d + I)\}1800 \times 1.5 = 1.24(1.165 + .25).25$
 $\times 1800 \times 1.5 = 1185$ lb

Insulator = $170 \times 1.5 = 255$ lb

Total = 4350 lb

Ground Wire Loads on Tower

Transverse

Wind = $4 \text{ psf} \times 0.849/12 \times 1500 \times 2.5 = 1060$ lb

Line Angle = $2 \times 2400 \times \sin 2.5 \times 1.65 = 350$ lb

Total = 1410 lb

15.3 Design of Steel Lattice Tower

15.3.1 Tower Geometry

A typical single circuit, horizontal configuration, self-supported lattice tower is shown in Figure 15.3. The design of a steel lattice tower begins with the development of a conceptual design, which establishes the geometry of the structure. In developing the geometry, structure dimensions are established for the tower window, crossarms and bridge, shield wire peak, bracing panels, and the slope of the

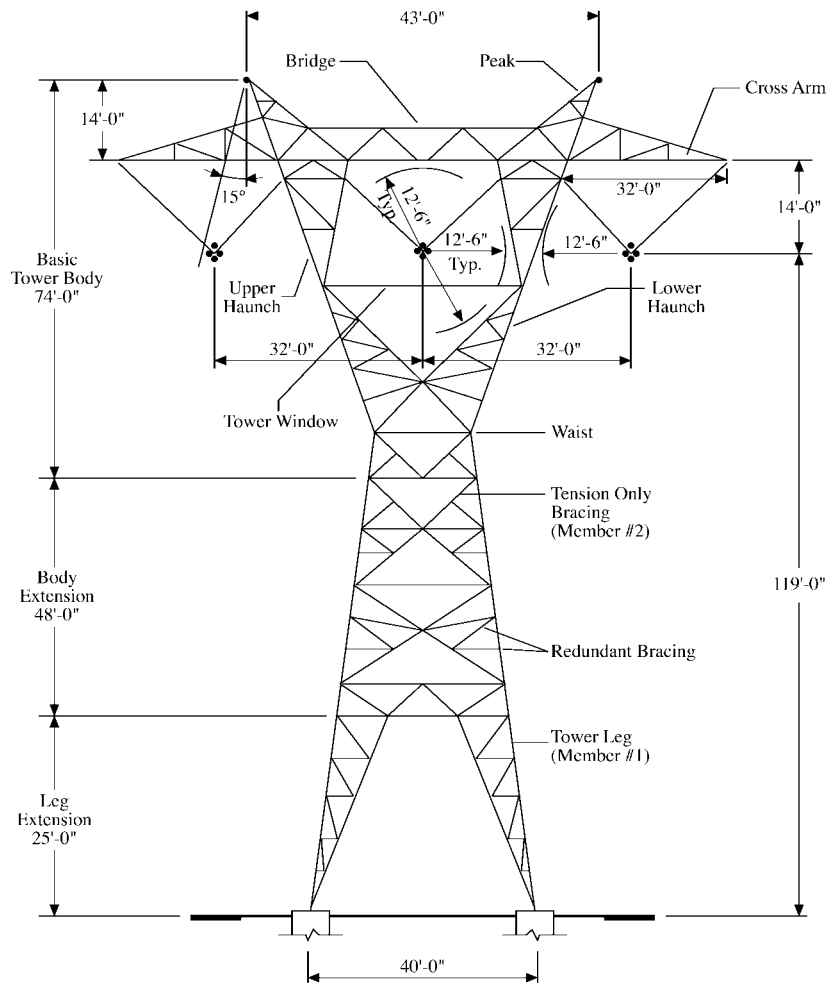

FIGURE 15.3: Single circuit lattice tower.

tower leg below the waist. The most important criteria for determining structure geometry are the minimum phase to phase and phase to steel clearance requirements, which are functions of the line voltage. Spacing of phase conductors may sometimes be dictated by conductor [galloping](#) considerations. Height of the tower peak above the crossarm is based on shielding considerations for lightning protection. The width of the tower base depends on the slope of the tower leg below the waist. The overall structure height is governed by the span length of the conductors between structures.

The lattice tower is made up of a basic body, body extension, and leg extensions. Standard designs are developed for these components for a given tower type. The basic body is used for all the towers regardless of the height. Body and leg extensions are added to the basic body to achieve the desired tower height.

The primary members of a tower are the leg and the bracing members which carry the vertical and shear loads on the tower and transfer them to the foundation. Secondary or redundant bracing members are used to provide intermediate support to the primary members to reduce their unbraced length and increase their load carrying capacity. The slope of the tower leg from the waist down has a significant influence on the tower weight and should be optimized to achieve an economical tower

design. A flatter slope results in a wider tower base which reduces the leg size and the foundation size, but will increase the size of the bracing. Typical leg slopes used for towers range from 3/4 in. 12 for light tangent towers to 2 1/2 in. 12 for heavy deadend towers.

The minimum included angle ∞ between two intersecting members is an important factor for proper force distribution. Reference [3] recommends a minimum included angle of 15° , intended to develop a truss action for load transfer and to minimize moment in the member. However, as the tower loads increase, the preferred practice is to increase the included angle to 20° for angle towers and 25° for deadend towers [23].

Bracing members below the waist can be designed as a tension only or tension compression system as shown in Figure 15.4. In a tension only system shown in (a), the bracing members are designed

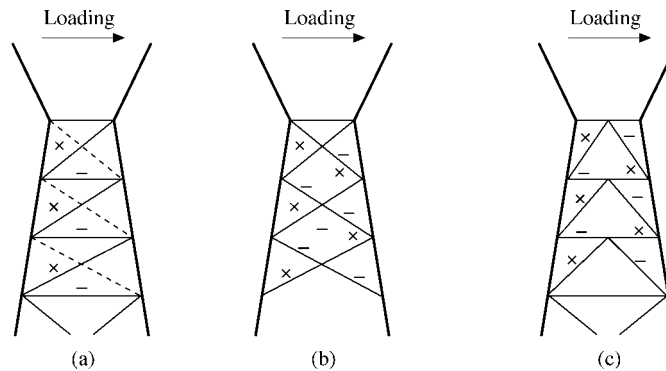

FIGURE 15.4: Bracing systems.

to carry tension forces only, the compression forces being carried by the horizontal strut. In a tension/compression system shown in (b) and (c), the braces are designed to carry both tension and compression. A tension only system may prove to be economical for lighter tangent towers. But for heavier towers, a tension/compression system is recommended as it distributes the load equally to the tower legs.

A **staggered bracing** pattern is sometimes used on the adjacent faces of a tower for ease of connections and to reduce the number of bolt holes at a section. Tests [23] have shown that staggering of main bracing members may produce significant moment in the members especially for heavily loaded towers. For heavily loaded towers, the preferred method is to stagger redundant bracing members and connect the main bracing members on the adjacent faces at a common panel point.

15.3.2 Analysis and Design Methodology

The ASCE Guide for Design of Steel Transmission Towers [3] is the industry document governing the analysis and design of lattice steel towers. A lattice tower is analyzed as a space truss. Each member of the tower is assumed pin-connected at its joints carrying only axial load and no moment. Today, finite element computer programs [12, 21, 17] are the typical tools for the analysis of towers for ultimate design loads. In the analytical model the tower geometry is broken down into a discrete number of joints (nodes) and members (elements). User input consists of nodal coordinates, member end incidences and properties, and the tower loads. For symmetric towers, most programs can generate the complete geometry from a part of the input. Loads applied on the tower are ultimate loads which include overload capacity factors discussed in Section 15.2. Tower members are then designed to

the yield strength or the buckling strength of the member. Tower members typically consist of steel angle sections, which allow ease of connection. Both single- and double-angle sections are used. Aluminum towers are seldom used today due to the high cost of aluminum. Steel types commonly used on towers are ASTM A-36 ($F_y = 36$ ksi) or A-572 ($F_y = 50$ ksi). The most common finish for steel towers is hot-dipped galvanizing. Self-weathering steel is no longer used for towers due to the “pack-out” problems experienced in the past resulting in damaged connections.

Tower members are designed to carry axial compressive and tensile forces. Allowable stress in compression is usually governed by buckling, which causes the member to fail at a stress well below the yield strength of the material. Buckling of a member occurs about its weakest axis, which for a single angle section is at an inclination to the geometric axes. As the unsupported length of the member increases, the allowable stress in buckling is reduced.

Allowable stress in a tension member is the full yield stress of the material and does not depend on the member length. The stress is resisted by a net cross-section, the area of which is the gross area minus the area of the bolt holes at a given section. Tension capacity of an angle member may be affected by the type of end connection [3]. For example, when one leg of the angle is connected, the tension capacity is reduced by 10%. A further reduction takes place when only the short leg of an unequal angle is connected.

15.3.3 Allowable Stresses

Compression Member

The allowable compressive stress in buckling on the gross cross-sectional area of axially loaded compression members is given by the following equations [3]:

$$F_a = \left[1 - (KL/R)^2 / (2Cc^2) \right] F_y \quad \text{if } KL/R = Cc \text{ or less} \quad (15.6)$$

$$F_a = 286000 / (kl/r)^2 \quad \text{if } KL/R > Cc \quad (15.7)$$

$$Cc = (3.14)(2E/F_y)^{1/2} \quad (15.8)$$

where

F_a = allowable compressive stress (ksi)

F_y = yield strength (ksi)

E = modulus of elasticity (ksi)

L/R = maximum slenderness ratio = unbraced length / radius of gyration

K = effective length coefficient

The angle member must also be checked for local buckling considerations. If the ratio of the angle effective width to angle thickness (w/t) exceeds $80/(F_y)^{1/2}$, the value of F_a will be reduced in accordance with the provisions of Reference [3].

The above formulas indicate that the allowable buckling stress is largely dependent on the effective slenderness ratio (kl/r) and the material yield strength (F_y). It may be noted, however, that F_y influences the buckling capacity for short members only ($kl/r < Cc$). For long members ($kl/r > Cc$), the allowable buckling stress is unaffected by the material strength.

The slenderness ratio is calculated for different axes of buckling and the maximum value is used for the calculation of allowable buckling stress. In some cases, a compression member may have an intermediate lateral support in one plane only. This support prevents weak axis and in-plane buckling but not the out-of-plane buckling. In such cases, the slenderness ratio in the member geometric axis will be greater than in the member weak axis, and will control the design of the member.

The effective length coefficient K adjusts the member slenderness ratio for different conditions of framing eccentricity and the restraint against rotation provided at the connection. Values of K

for six different end conditions, curves one through six, have been defined in Reference [3]. This reference also specifies maximum slenderness ratios of tower members, which are as follows:

Type of Member	Maximum $K L/R$
Leg	150
Bracing	200
Redundant	250

Tests have shown that members with very low L/R are subjected to substantial bending moment in addition to axial load. This is especially true for heavily loaded towers where members are relatively stiff and multiple bolted rigid joints are used [22]. A minimum L/R of 50 is recommended for compression members.

Tension Members

The allowable tensile force on the net cross-sectional area of a member is given by the following equation [3]:

$$P_t = F_y \cdot A_n \cdot K \quad (15.9)$$

where

- P_t = allowable tensile force (kips)
- F_y = yield strength of the material (ksi)
- A_n = net cross-sectional area of the angle after deducting for bolt holes (in.²). For unequal angles, if the short leg is connected, A_n is calculated by considering the unconnected leg to be the same size as the connected leg
- K = 1.0 if both legs of the angle connected
= 0.9 if one leg connected

The allowable tensile force must also meet the **block shear** criteria at the connection in accordance with the provisions of Reference [3].

Although the allowable force in a tension member does not depend on the member length, Reference [3] specifies a maximum L/R of 375 for these members. This limit minimizes member vibration under everyday steady state wind, and reduces the risk of fatigue in the connection.

15.3.4 Connections

Transmission towers typically use bearing type bolted connections. Commonly used bolt sizes are 5/8", 3/4", and 7/8" in diameter. Bolts are tightened to a snug tight condition with torque values ranging from 80 to 120 ft-lb. These torques are much smaller than the torque used in friction type connections in steel buildings. The snug tight torque ensures that the bolts will not slip back and forth under everyday wind loads thus minimizing the risk of fatigue in the connection. Under full design loads, the bolts would slip adding flexibility to the joint, which is consistent with the truss assumption.

Load carrying capacity of the bolted connections depends on the shear strength of the bolt and the bearing strength of the connected plate. The most commonly used bolt for transmission towers is A-394, Type 0 bolt with an allowable shear stress of 55.2 ksi across the threaded part. The maximum allowable stress in bearing is 1.5 times the minimum tensile strength of the connected part or the bolt. Use of the maximum bearing stress requires that the edge distance from the center of the bolt hole to the edge of the connected part be checked in accordance with the provisions of Reference [3].

15.3.5 Detailing Considerations

Bolted connections are detailed to minimize eccentricity as much as possible. Eccentric connections give rise to a bending moment causing additional shear force in the bolts. Sometimes small eccentricities may be unavoidable and should be accounted for in the design. The detailing specification should clearly specify the acceptable conditions of eccentricity.

Figure 15.5 shows two connections, one with no eccentricity and the second with a small eccentricity. In the first case the lines of force passing through the center of gravity (c.g.) of the members

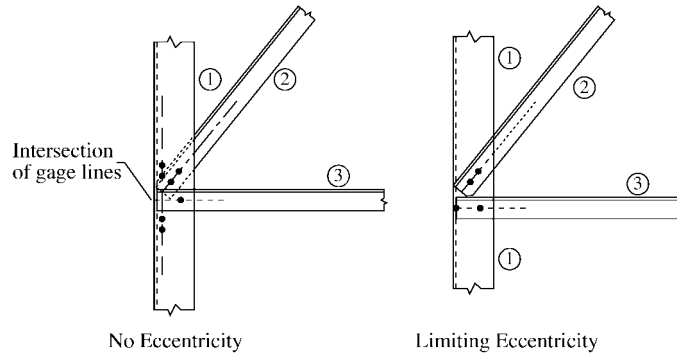

FIGURE 15.5: Brace details.

intersect at a common point. This is the most desired condition producing no eccentricity. In the second case, the lines of force of the two bracing members do not intersect with that of the leg member thus producing an eccentricity in the connection. It is common practice to accept a small eccentricity as long as the intersection of the lines of force of the bracing members does not fall outside the width of the leg member. In some cases it may be necessary to add gusset plates to avoid large eccentricities.

In detailing double angle members, care should be taken to avoid a large gap between the angles that are typically attached together by stitch bolts at specified intervals. Tests [23] have shown that a double angle member with a large gap between the angles does not act as a composite member. This results in one of the two angles carrying significantly more load than the other angle. It is recommended that the gap between the two angles of a double angle member be limited to 1/2 in.

The minimum size of a member is sometimes dictated by the size of the bolt on the connected leg. The minimum width of members that can accommodate a single row of bolts is as follows:

Bolt diameter	Minimum width of member
5/8"	1 3/4"
3/4"	2"
7/8"	2 1/2"

Tension members are detailed with draw to facilitate erection. Members 15 ft in length, or less, are detailed 1/8 in. short, plus 1/16 in. for each additional 10 ft. Tension members should have at least two bolts on one end to facilitate the draw.

15.3.6 Tower Testing

Full scale load tests are conducted on new tower designs and at least the tangent tower to verify the adequacy of the tower members and connections to withstand the design loads specified for that structure. Towers are required to pass the tests at 100% of the ultimate design loads. Tower tests

also provide insight into actual stress distribution in members, fit-up verification and action of the structure in deflected positions. Detailed procedures of tower testing are given in Reference [3].

EXAMPLE 15.2:

Description

Check the adequacy of the following tower components shown in Figure 15.3.
Member 1 (compressive leg of the leg extension)

Member force = 132 kips (compression)

Angle size = $L5 \times 5 \times 3/8$ "

$F_y = 50$ ksi

Member 2 (tension member)

Tensile force = 22 kips

Angle size = $L2\ 1/2 \times 2 \times 3/16$ (long leg connected)

$F_y = 36$ ksi

Bolts at the splice connection of Member 1

Number of 5/8" bolts = 6 (Butt Splice)

Type of bolt = A-394, Type O

Solution

Member 1

Member force = 132 kips (compression)

Angle size = $L5 \times 5 \times 3/8$ "

$F_y = 50$ ksi

Find maximum L/R

Properties of $L5 \times 5 \times 3/8$ "

Area = 3.61 in.²

$r_x = r_y = 1.56$ in.

$r_z = 0.99$ in.

Member 1 has the same bracing pattern in adjacent planes. Thus, the unsupported length is the same in the weak ($z - z$) axis and the geometric axes ($x - x$ and $y - y$).

$$l_z = l_x = l_y = 61"$$

Maximum $L/R = 61/0.99 = 61.6$

Allowable Compressive Stress:

Using Curve 1 for leg member (no framing eccentricity), per Reference [3], $k = 1.0$

$$KL/R = L/R = 61.6$$

$$\begin{aligned}
C_c &= (3.14)(2E/F_y)^{1/2} \\
&= (3.14)(2 \times 29000/50)^{1/2} \\
&= 107.0 \text{ which is } > KL/R \\
F_a &= \left[1 - (KL/R)^2 / (2C_c^2) \right] F_y \\
&= \left[1 - (61.6)^2 / (2 \times 107.0^2) \right] 50.0 \\
&= 41.7 \text{ ksi}
\end{aligned}$$

Allowable compressive load = 41.7 ksi \times 3.61 in.

$$= 150.6 \text{ kips} > 132 \text{ kips} \rightarrow \text{O.K.}$$

Check local buckling:

$$\begin{aligned}
w/t &= (5.0 - 7/8) / (3/8) = 11.0 \\
80/(F_y)^{1/2} &= 80/(50)^{1/2} = 11.3 > 11.0 \text{ O.K.}
\end{aligned}$$

Member 2

$$\begin{aligned}
\text{Tensile force} &= 22 \text{ kips} \\
\text{Angle size} &= L 2 - 1/2 \times 2 \times 3/16 \\
\text{Area} &= 0.81 \text{ in.}^2 \\
F_y &= 36 \text{ ksi}
\end{aligned}$$

Find tension capacity

$$\begin{aligned}
P_t &= F_y \cdot A_n \cdot K \\
\text{Diameter of bolt hole} &= 5/8" + 1/16" = 11/16"
\end{aligned}$$

Assuming one bolt hole deduction in 2 - 1/2" leg width,

$$\begin{aligned}
\text{Area of bolt hole} &= \text{angle th.} \times \text{hole diam.} \\
&= (3/16)(11/16) = 0.128 \text{ in.}^2
\end{aligned}$$

$$\begin{aligned}
A_n &= \text{gross area} - \text{bolt hole area} \\
&= 0.81 - 0.128 = 0.68 \text{ in.}^2 \\
K &= 0.9, \text{ since member end is connected by one leg} \\
P_t &= (36)(0.68)(0.9) = 22.1 \text{ kips} > 22.0 \text{ kips, O.K.}
\end{aligned}$$

Bolts for Member 1

$$\begin{aligned}
\text{Number of } 5/8" \text{ bolts} &= 6 \text{ (Butt Splice)} \\
\text{Type of bolt} &= \text{A-394, Type O} \\
\text{Shear Strength } F_v &= 55.2 \text{ ksi} \\
\text{Root area thru threads} &= 0.202 \text{ in.}^2
\end{aligned}$$

Shear capacity of bolts:

$$\begin{aligned} & \text{Bolts act in double shear at butt splice} \\ & \text{Shear capacity of 6 bolts in double shear} \\ & = 2 \times (\text{Root area}) \times 55.2 \text{ ksi} \times 6 \\ & = 133.8 \text{ kips} > 132 \text{ kips} \Rightarrow \text{O.K.} \end{aligned}$$

Bearing capacity of connected part:

$$\begin{aligned} & \text{Thickness of connected angle} = 3/8" \\ & F_y \text{ of angle} = 50 \text{ ksi} \\ & \text{Capacity of bolt in bearing} \\ & = 1.5 \times F_u \times \text{th. of angle} \times \text{dia. of bolt} \\ & F_u \text{ of 50 ksi material} = 65 \text{ ksi} \\ & \text{Capacity of 6 bolts in bearing} = 1.5 \times 65 \times 3/8 \times 5/8 \times 6 \\ & = 137.1 \text{ kips} > 132 \text{ kips, O.K.} \end{aligned}$$

15.4 Transmission Poles

15.4.1 General

Transmission poles made of wood, steel, or concrete are used on transmission lines at voltages up to 345-kv. Wood poles can be economically used for relatively shorter spans and lower voltages whereas steel poles and concrete poles have greater strength and are used for higher voltages. For areas where severe climatic loads are encountered, steel poles are often the most cost-effective choice.

Pole structures have two basic configurations: single pole and H-frame (Figure 15.1). Single pole structures are used for lower voltages and shorter spans. H-frame structures consist of two poles connected by a framing comprised of the cross arm, the V-braces, and the X-braces. The use of X-braces significantly increases the load carrying capacity of H-frame structures.

At line angles or deadend conditions, guying is used to decrease pole deflections and to increase their transverse or longitudinal structural strength. Guys also help prevent uplift on H-frame structures. Large deflections would be a hindrance in stringing operations.

15.4.2 Stress Analysis

Transmission poles are flexible structures and may undergo relatively large lateral deflections under design loads. A secondary moment (or $P - \Delta$ effect) will develop in the poles due to the lateral deflections at the load points. This secondary moment can be a significant percent of the total moment. In addition, large deflections of poles can affect the magnitude and direction of loads caused by the line tension and stringing operations. Therefore, the effects of pole deflections should be included in the analysis and design of single and multi-pole transmission structures.

To properly analyze and design transmission structures, the standard industry practice today is to use nonlinear finite element computer programs. These computer programs allow efficient evaluation of pole structures considering geometric and/or material nonlinearities. For wood poles, there are several popular computer software programs available from EPRI [15]. They are specially developed for design and analysis of wood pole structures. Other general purpose commercial programs such as SAP-90 and STAAD [20, 10] are available for performing small displacement $P - \Delta$ analysis.

15.4.3 Tubular Steel Poles

Steel transmission poles are fabricated from uniformly tapered hollow steel sections. The cross-sections of the poles vary from round to 16-sided polygonal with the 12-sided dodecagonal as the most common shape. The poles are formed into design cross-sections by braking, rolling, or stretch bending.

For these structures the usual industry practice is that the analysis, design, and detailing are performed by the steel pole supplier. This facilitates the design to be more compatible with fabrication practice and available equipment.

Design of tubular steel poles is governed by the ASCE Manual # 72 [9]. The Manual provides detailed design criteria including allowable stresses for pole masts and connections and stability considerations for global and local buckling. It also defines the requirements for fabrication, erection, load testing, and quality assurance.

It should be noted that steel transmission pole structures have several unique design features as compared to other tubular steel structures. First, they are designed for ultimate, or maximum anticipated loads. Thus, stress limits of the Manual #72 are not established for working loads but for ultimate loads.

Second, Manual #72 requires that stability be provided for the structure as a whole and for each structural element. In other words, the effects of deflected structural shape on structural stability should be considered in the evaluation of the whole structure as well as the individual element. It relies on the use of the large displacement nonlinear computer analysis to account for the $P - \Delta$ effect and check for stability. To prevent excessive deflection effects, the lateral deflection under factored loads is usually limited to 5 to 10% of the pole height. Pre-cambering of poles may be used to help meet the imposed deflection limitation on angle structures.

Lastly, due to its polygonal cross-sections combined with thin material, special considerations must be given to calculation of member section properties and assessment of local buckling.

To ensure a polygonal tubular member can reach yielding on its extreme fibers under combined axial and bending compression, local buckling must be prevented. This can be met by limiting the width to thickness ratio, w/t , to $240/(F_y)^{1/2}$ for tubes with 12 or fewer sides and $215/(F_y)^{1/2}$ for hexadecagonal tubes. If the axial stress is 1 ksi or less, the w/t limit may be increased to $260/(F_y)^{1/2}$ for tubes with 8 or fewer sides [9].

Special considerations should be given in the selection of the pole materials where poles are to be subjected to subzero temperatures. To mitigate potential brittle fracture, use of steel with good impact toughness in the longitudinal direction of the pole is necessary. Since the majority of pole structures are manufactured from steels of a yield strength of 50 to 65 ksi (i.e., ASTM A871 and A572), it is advantageous to specify a minimum Charpy-V-notch impact energy of 15 ft-lb at 0°F for plate thickness of 1/2 in. or less and 15 ft-lb at -20°F for thicker plates. Likewise, high strength anchor bolts made of ASTM A615-87 Gr.75 steel should have a minimum Charpy V-notch of 15 ft-lbs at -20°F.

Corrosion protection must be considered for steel poles. Selection of a specific coating or use of weathering steel depends on weather exposure, past experience, appearance, and economics. Weathering steel is best suited for environments involving proper wetting and drying cycles. Surfaces that are wet for prolonged periods will corrode at a rapid rate. A protective coating is required when such conditions exist. When weathering steel is used, poles should also be detailed to provide good drainage and avoid water retention. Also, poles should either be sealed or well ventilated to assure the proper protection of the interior surface of the pole. Hot-dip galvanizing is an excellent alternate means for corrosion protection of steel poles above grade. Galvanized coating should comply with ASTM A123 for its overall quality and for weight/thickness requirements.

Pole sections are normally joined by telescoping or slip splices to transfer shears and moments. They are detailed to have a lap length no less than 1.5 times the largest inside diameter. It is important

to have a tight fit in slip joint to allow load transfer by friction between sections. Locking devices or flanged joints will be needed if the splice is subjected to uplift forces.

15.4.4 Wood Poles

Wood poles are available in different species. Most commonly used are Douglas Fir and Southern Yellow Pine, with a rupture bending stress of 8000 psi, and Western Red Cedar with a rupture bending stress of 6000 psi. The poles are usually treated with a preservative (pentachlorophenol or creosote). Framing materials for crossarm and braces are usually made of Douglas Fir or Southern Yellow Pine. Crossarms are typically designed for a rupture bending stress of 7400 psi.

Wood poles are grouped into a wide range of classes and heights. The classification is based on minimum circumference requirements specified by the American National Standard (ANSI) specification 05.1 for each species, each class, and each height [2]. The most commonly used pole classes are class 1, 2, 3, and H-1. Table 15.3 lists the moment capacities at groundline for these common classes of wood poles. Poles of the same class and length have approximately the same capacity regardless of the species.

TABLE 15.3 Moment Capacity at Ground Line for 8000 psi
Douglas Fir and Southern Pine Poles

Class		H-1	1	2	3
Minimum circumference at top (in.)		29	27	25	23
Length of pole (ft)	Ground line distance from butt (ft)	Ultimate moment capacity, ft-lb			
	50	7	220.3	187.2	152.1
55	7.5	246.4	204.2	167.1	134.7
60	8	266.8	222.3	183.0	148.7
65	8.5	288.4	241.5	200.0	163.5
70	9	311.2	261.9	218.1	179.4
75	9.5	335.3	283.4	230.3	190.2
80	10	360.6	306.2	250.2	201.5
85	10.5	387.2	321.5	263.7	213.3
90	11	405.2	337.5	285.5	225.5
95	11	438.0	357.3	303.2	—
100	11	461.5	387.3	321.5	—
105	12	461.5	387.3	321.5	—
110	12	514.2	424.1	354.1	—

The basic design principle for wood poles, as in steel poles, is to assure that the applied loads with appropriate overload capacity factors do not exceed the specified stress limits.

In the design of a single unguayed wood pole structure, the governing criteria is to keep the applied moments below the moment capacity of wood poles, which are assumed to have round solid sections. Theoretically the maximum stress for single unguayed poles under lateral load does not always occur at the ground line. Because all data have been adjusted to the ground line per ANSI 05.1 pole dimensions, only the stress or moment at the ground line need to be checked against the moment capacity. The total ground line moment is the sum of the moment due to transverse wire loads, the moment due to wind on pole, and the secondary moment. The moment due to the eccentric vertical load should also be included if the conductors are not symmetrically arranged.

Design guidelines for wood pole structures are given in the REA (Rural Electrification Administration) Bulletin 62-1 [18] and IEEE Wood Transmission Structural Design Guide [15]. Because of the use of high overload factors, the REA and NESC do not require the consideration of secondary moments in the design of wood poles unless the pole is very flexible. It also permits the use of rupture stress. In contrast, IEEE requires the secondary moments be included in the design and recommends

lower overload factors and use of reduction factors for computing allowable stresses. Designers can use either of the two standards to evaluate the allowable horizontal span for a given wood pole. Conversely, a wood pole can be selected for a given span and pole configuration.

For H-frames with X-braces, maximum moments may not occur at ground line. Sections at braced location of poles should also be checked for combined moments and axial loads.

15.4.5 Concrete Poles

Prestressed concrete poles are more durable than wood or steel poles and they are aesthetically pleasing. The reinforcing of poles consists of a spiral wire cage to prevent longitudinal cracks and high strength longitudinal strands for prestressing. The pole is spinned to achieve adequate concrete compaction and a dense smooth finish. The concrete pole typically utilizes a high strength concrete (around 12000 psi) and 270 ksi prestressing strands. Concrete poles are normally designed by pole manufacturers. The guideline for design of concrete poles is given in Reference [8]. Standard concrete poles are limited by their ground line moment capacity.

Concrete poles are, however, much heavier than steel or wood poles. Their greater weight increases transportation and handling costs. Thus, concrete poles are used most cost-effectively when there is a manufacturing plant near the project site.

15.4.6 Guyed Poles

At line angles and deadends, single poles and H-frames are guyed in order to carry large transverse loads or longitudinal loads. It is a common practice to use bisector guys for line angles up to 30° and in-line guys for structures at deadends or larger angles. The large guy tension and weight of conductors and insulators can exert significant vertical compression force on poles. Stability is therefore a main design consideration for guyed pole structures.

Structural Stability

The overall stability of guyed poles under combined axial compression and bending can be assessed by either a large displacement nonlinear finite element stress analysis or by the use of simplified approximate methods.

The rigorous stability analysis is commonly used by steel and concrete pole designers. The computer programs used are capable of assessing the structural stability of the guyed poles considering the effects of the stress-dependent structural stiffness and large displacements. But, in most cases, guys are modeled as tension-only truss elements instead of geometrically nonlinear cable elements. The effect of initial tension in guys is neglected in the analysis.

The simplified stability method is typically used in the design of guyed wood poles. The pole is treated as a strut carrying axial loads only and guys are to carry the lateral loads. The critical buckling load for a tapered guyed pole may be estimated by the Gere and Carter method [13].

$$P_{cr} = P(Dg/Da)^e \quad (15.10)$$

where P is the Euler buckling load for a pole with a constant diameter of Da at guy attachment and is equal to $9.87 EI/(kl)^2$; Dg is the pole diameter at groundline; kl is the effective column length depending on end condition; e is an exponent constant equal to 2.7 for fixed-free ends and 2.0 for other end conditions. It should be noted that the exact end condition at the guyed attachment is difficult to evaluate. Common practice is to assume a hinged-hinged condition with k equal to 1.0. A higher k value should be chosen when there is only a single back guy.

For a pole guyed at multiple levels, the column stability may be checked as follows by comparing the maximum axial compression against the critical buckling load, P_{cr} , at the lowest braced location

of the pole [15]:

$$[P1 + P2 + P3 + \dots] / Pcr < 1 / OCF \quad (15.11)$$

where OCF is the overload capacity factor and $P1$, $P2$, and $P3$ are axial loads at various guy levels.

Design of Guys

Guys are made of strands of cable attached to the pole and anchor by shackles, thimbles, clips, or other fittings. In the tall microwave towers, initial tension in the guys is normally set between 8 to 15% of the rated breaking strength (RBS) of the cable. However, there is no standard initial tension specified for guyed transmission poles. Guys are installed before conductors and ground wires are strung and should be tightened to remove slack without causing noticeable pole deflections. Initial tension in guys are normally in the range of 5 to 10% of RBS. For design of guys, the maximum tension under factored loads per NESC shall not exceed 90% of the cable breaking strength. Note that for failure containment (broken conductors) the guy tension may be limited to 0.85 RBS. A lower allowable of 65% of RBS would be needed if a linear load-deformation behavior of guyed poles is desired for extreme wind and ice conditions per ASCE Manual #72.

Considerations should be given to the range of ambient temperatures at the site. A large temperature drop may induce a significant increase of guy tension. Guys with an initial tension greater than 15% of RBS of the guy strand may be subjected to aeolian vibrations.

EXAMPLE 15.3:

Description

Select a Douglas Fir pole unguyed tangent structure shown below to withstand the NESC heavy district loads. Use an OCF of 2.5 for wind and 1.5 for vertical loads and a strength reduction factor of 0.65. Horizontal load span is 400 ft and vertical load span is 500 ft. Examine both cases with and without the $P - \Delta$ effect. The NESC heavy loading is 0.5 in. ice, 4 psf wind, and 0°F.

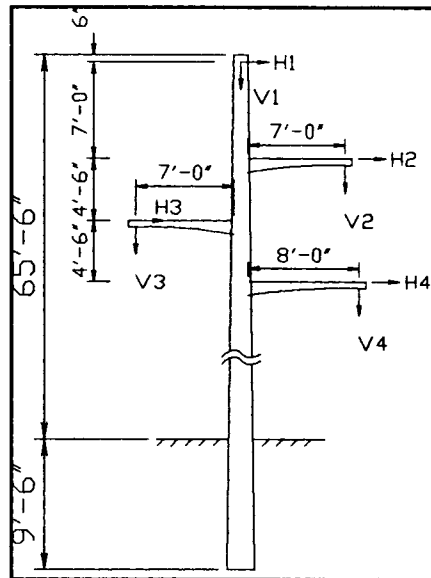

Ground Wire Loads

$$H1 = 0.453\#/ft \quad V1 = 0.807\#/ft$$

Conductor Loads

$$H2 = H3 = H4 = 0.732\#/ft$$

$$V2 = V3 = V4 = 2.284\#/ft$$

$$\text{Horizontal Span} = 400 \text{ ft}$$

$$\text{Vertical Span} = 500 \text{ ft}$$

$$\text{Line Angle} = 0^\circ$$

Solution A 75-ft class 1 pole is selected as the first trial. The pole will have a length of 9.5 ft buried below the groundline. The diameter of the pole is 9.59 in. at the top (Dt) and 16.3 in. at the groundline (Dg). Moment at groundline due to transverse wind on wire loads is

$$Mh = (0.732)(2.5)(400)(58 + 53.5 + 49) + (0.453)(2.5)(400)(65) = 146930 \text{ ft-lbs}$$

Moment at groundline due to vertical wire loads

$$Mv = (2.284)(1.5)(500)(8 + 7 - 7) = 13700 \text{ ft-lbs}$$

Moment due to 4 psf wind on pole

$$\begin{aligned} Mw &= (\text{wind pressure}) (OCF)H^2(Dg + 2Dt)/72 \\ &= (4)(2.5)(65.5)^2(16.3 + 9.59 \times 2)/72 = 21140 \text{ ft-lbs} \end{aligned}$$

The total moment at groundline

$$Mt = 146930 + 13700 + 21140 = 181770 \text{ ft-lbs or } 181.7 \text{ ft-kips}$$

This moment is less than the moment capacity of the 75-ft class 1 pole, 184.2 ft-kips (i.e., 0.65×283.4 , refer to Table 15.3). Thus, the 75-ft class 1 pole is adequate if the $P - \Delta$ effect is ignored.

To include the effect of the pole displacement, the same pole was modeled on the SAP-90 computer program using a modulus of elasticity of 1920 ksi. Under the factored NESC loading, the maximum displacement at the top of the pole is 67.9 in. The associated secondary moment at the groundline is 28.5 ft-kips, which is approximately 15.7% of the primary moment. As a result, a 75-ft class H1 Douglas Fir pole with an allowable moment of 217.9 ft-kips is needed when the $P - \Delta$ effect is considered.

15.5 Transmission Tower Foundations

Tower foundation design requires competent engineering judgement. Soil data interpretation is critical as soil and rock properties can vary significantly along a transmission line. In addition, construction procedures and backfill compaction greatly influence foundation performance.

Foundations can be designed for site specific loads or for a standard maximum load design. The best approach is to use both a site specific and standardized design. The selection should be based on the number of sites that will have a geotechnical investigation, inspection, and verification of soil conditions.

15.5.1 Geotechnical Parameters

To select and design the most economical type of foundation for a specific location, soil conditions at the site should be known through existing site knowledge or new explorations. Inspection should also be considered to verify that the selected soil parameters are within the design limits. The subsurface investigation program should be consistent with foundation loads, experience in the right-of-way conditions, variability of soil conditions, and the desired level of reliability.

In designing transmission structure foundations, considerations must be given to frost penetration, expansive or shrinking soils, collapsing soils, black shales, sinkholes, and permafrost. Soil investigation should consider the unit weight, angle of internal friction, cohesion, blow counts, and modulus of deformation. The blow count values are correlated empirically to the soil value. Lab tests can measure the soil properties more accurately especially in clays.

15.5.2 Foundation Types—Selection and Design

There are many suitable types of tower foundations such as steel grillages, pressed plates, concrete footings, precast concrete, rock foundations, drilled shafts with or without bells, direct embedment, pile foundations, and anchors. These foundations are commonly used as support for lattice, poles, and guyed towers. The selected type depends on the cost and availability [14, 24].

Steel Grillages

These foundations consist entirely of steel members and should be designed in accordance with Reference [3]. The surrounding soil should not be considered as bracing the leg. There are pyramid arrangements that transfer the horizontal shear to the base through truss action. Other types transfer the shear through shear members that engage the lateral resistance of the compacted backfill. The steel can be purchased with the tower steel and concrete is not required at the site.

Cast in Place Concrete

Cast in place concrete foundation consists of a base mat and a square of cylindrical pier. Most piers are kept in vertical position. However, the pier may be battered to allow the axial loads in the tower legs to intersect the mat centroid. Thus, the horizontal shear loads are greatly reduced for deadends and large line angles. Either stub angles or anchor bolts are embedded in the top of the pier so that the upper tower section can be spliced directly to the foundation. Bolted clip angles, welded stud shear connectors, or bottom plates are added to the stub angle. This type can also be precast elsewhere and delivered to the site. The design is accomplished by Reference [1].

Drilled Concrete Shafts

The drilled concrete shaft is the most common type of foundation now being used to support transmission structures. The shafts are constructed by power auguring a circular excavation, placing the reinforcing steel and anchor, and pouring concrete. Tubular steel poles are attached to the shafts using base plates welded to the pole with anchor bolts embedded in the foundation (Figure 15.6a). Lattice towers are attached through the use of stub angles or base plates with anchor bolts. Loose granular soil may require a casing or a slurry. If there is a water level, tremie concrete is required. The casing, if used, should be pulled as the concrete is poured to allow friction along the sides. A minimum 4" slump should allow good concrete flow. Belled shafts should not be attempted in granular soil.

If conditions are right, this foundation type is the fastest and most economical to install as there is no backfilling required with dependency on compaction. Lateral procedures for design of drilled shafts under lateral and uplift loads are given in References [14] and [25].

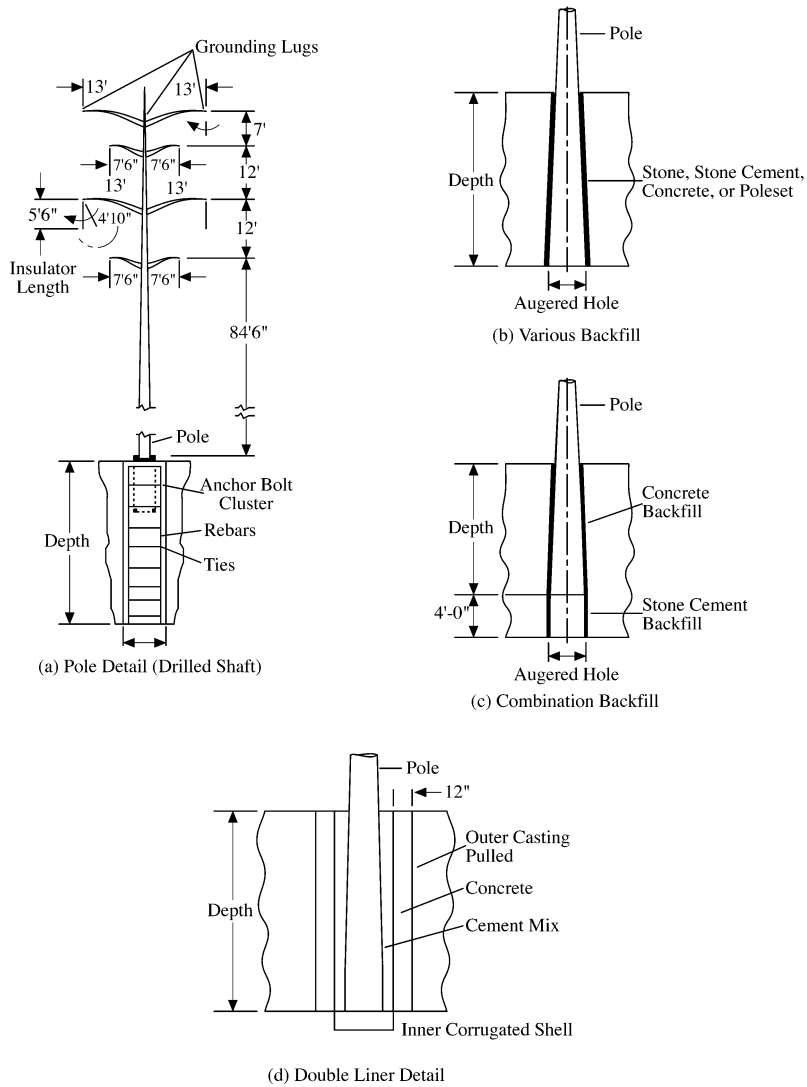

FIGURE 15.6: Direct embedment.

Rock Foundations

If bedrock is close to the surface, a rock foundation can be installed. The rock quality designation (RQD) is useful in evaluating rock. Uplift capacity can be increased with drilled anchor rods or by shaping the rock. Blasting may cause shatter or fracture to rock. Drilling or power hammers are therefore preferred. It is also helpful to wet the hole before placing concrete to ensure a good bond.

Direct Embedment

Direct embedment of structures is the oldest form of foundation as it has been used on wood pole transmission lines since early times. Direct embedment consists of digging a hole in the ground, inserting the structure into the hole, and backfilling. Thus, the structure acts as its own foundation

transferring loads to the *in situ* soil via the backfill. The backfill can be a stone mix, stone-cement mix, excavated material, polyurethane foam, or concrete (see Figure 15.6b and c). The disadvantage of direct embedment is the dependency on the quality of backfill material. To accurately get deflection and rotation of direct embedded structures, the stiffness of the embedment must be considered. Rigid caisson analysis will not give accurate results. The performance criteria for deflection should be for the combined pole and foundation. Instability of the augured hole and the presence of water may require a liner or double liners (see Figure 15.6d). The design procedure for direct embedment is similar to drilled shafts [14, 25, 16].

Vibratory Shells

Steel shells are installed by using a vibratory hammer. The top 6 or 8 ft (similar to slip joint requirements) of soil inside the shell is excavated and the pole is inserted. The annulus is then filled with a high strength non-shrink grout. The pole can also be attached through a flange connection which eliminates excavating and grouting. The shell design is similar to drilled shafts.

Piles

Piles are used to transmit loads through soft soil layers to stiffer soils or rock. The piles can be of wood, prestressed concrete, cast in place concrete, concrete filled shells, steel H piles, steel pipes filled with concrete, and prestressed concrete cylinder piles. The pipe selection depends on the loads, materials, and cost. Pile foundations are normally used more often for lattice towers than for H-framed structures or poles because piles have high axial load capacity and relatively low shear and bending capacity.

Besides the external loading, piles can be subjected to the handling, drying, and soil stresses. If piles are not tested, the design should be conservative. Reference [14] should be consulted for bearing, uplift, lateral capacity, and settlement. Driving formulas can be used to estimate dynamic capacity of the pile or group. Timber piles are susceptible to deterioration and should be treated with a preservative.

Anchors

Anchors are usually used to support guyed structures. The uplift capacity of rock anchors depends on the quality of the rock, the bond of the grout and rock with steel, and the steel strength. The uplift capacity of soil anchors depends on the resistance between grout and soil and end bearing if applicable. Multi-belled anchors in cohesive soil depend on the number of bells. The capacity of Helix anchors can be determined by the installation torque developed by the manufacturer. Spread anchor plate anchors depend on the soil weight plus the soil resistance.

Anchors provide resistance to upward forces. They may be prestressed or deadman anchors. Deadmen anchors are not loaded until the structure is loaded, while prestressed anchors are loaded when installed or proof loaded.

Helix soil anchors have deformed plates installed by rotating the anchor into the ground with a truck-mounted power auger. The capacity of the anchor is correlated to the amount of torque. Anchors are typically designed in accordance with the procedure given in Reference [14].

15.5.3 Anchorage

Anchorage of the transmission tower can consist of anchor bolts, stub angles with clip angles, or shear connectors and designed by Reference [3]. The anchor bolts can be smooth bars with a nut or head at the bottom, or deformed reinforcing bars with the embedment determined by Reference [1]. If the anchor bolt base plate is in contact with the foundation, the lateral or shear load is transferred to the foundation by **shear friction**. If there is no contact between the base plate and the concrete (anchor

bolts with leveling nuts), the lateral load is transferred to the concrete by the side bearing of the anchor bolt. Thus, anchor bolts should be designed for a combination of tension (or compression), shear, and bending by linear interaction.

15.5.4 Construction and Other Considerations

Backfill

Excavated foundations require a high level of compaction that should be inspected and tested. During the original design the degree of compaction that may actually be obtained should be considered. This construction procedure of excavation and compaction increases the foundation costs.

Corrosion

The type of soil, moisture, and stray electric currents could cause corrosion of metals placed below the ground. Obtaining resistivity measurements would determine if a problem exists. Consideration could then be given to increasing the steel thickness, a heavier galvanizing coat, a bituminous coat, or in extreme cases a cathodic protection system. Hard epoxy coatings can be applied to steel piles. In addition, concrete can deteriorate in acidic or high sulfate soils.

15.5.5 Safety Margins for Foundation Design

The NESC requires the foundation design loads to be taken the same as NESC load cases used for design of the transmission structures. The engineer must use judgement in determining safety factors depending on the soil conditions, importance of the structures, and reliability of the transmission line. Unlike structural steel or concrete, soil does not have well-defined properties. Large variations exist in the geotechnical parameters and construction techniques. Larger safety margins should be provided where soil conditions are less uniform and less defined.

Although foundation design is based on ultimate strength design, there is no industry standard on strength reduction factors at present. The latest research [11] shows that uplift test results differed significantly from analytical predictions and uplift capacity. Based on a statistical analysis of 48 uplift tests on drilled piers and 37 tests on grillages and plates, the coefficients of variation were found to be approximately 30%. To achieve a 95% reliability, which is a 5% exclusion limit, an uplift strength reduction factor of 0.8 to 0.9 is recommended for drilled shafts and 0.7 to 0.8 for backfilled types of foundations.

15.5.6 Foundation Movements

Foundation movements may change the structural configuration and cause load redistribution in lattice structures and framed structures. For pole structures a small foundation movement can induce a large displacement at the top of the pole which will reduce ground clearance or cause problems in wire stringing. The amount of tolerable foundation settlements depends on the structure type and load conditions. However, there is no industry standard at the present time. For lattice structures, it is suggested that the maximum vertical foundation movement be limited to 0.004 times the base dimensions. If larger movements are expected, foundations can be designed to limit their movements or the structures can be designed to withstand the specified foundation movements.

15.5.7 Foundation Testing

Transmission line foundations are load tested to verify the foundation design for specific soils, adequacy of the foundation, research investigation, and to determine strength reduction factors. The

load tests will refine foundation selection and verify the soil conditions and construction techniques. The load tests may be in uplift, download, lateral loads, overturning moment, or any necessary combination.

There should also be a geotechnical investigation at the test site to correlate the soil data with other locations. There are various test set-ups, depending on what type of loading is to be applied and what type of foundation is to be tested. The results should compare the analytical methods used to actual behaviors. The load vs. the foundation movements should be plotted in order to evaluate the foundation performance.

15.5.8 Design Examples

EXAMPLE 15.4: Spread Footing

Problem—Determine the size of a square spread footing for a combined moment (175 ft-k) and axial load (74 kips) using two alternate methods. In the first method, the minimum factor of safety against overturning is 1.7 and the maximum soil pressure is kept below an allowable soil bearing of 4000 psf. In the second method, no factor of safety against overturning is specified. Instead, the spread footing is designed so that the resultant reaction is within the middle third. This example shows that keeping the resultant in the middle third is a conservative design.

Solution

Method 1

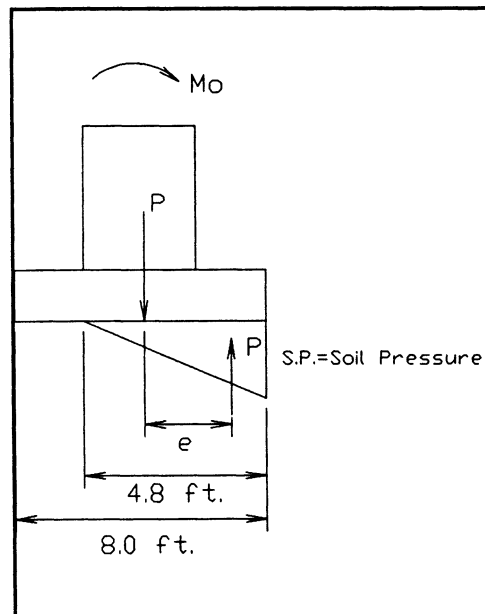

Try a 8 ft x 8 ft footing

$$\begin{aligned} P &= 74 \text{ kips} \\ M_o &= 175 \text{ kip-ft} \end{aligned}$$

P increase for footing size increase = 0.3 kips/ft^2

$$e = 175 \text{ k-ft}/74 \text{ kips} = 2.4 \text{ ft} > 8 \text{ ft}/6 = 1.33 \text{ ft}$$

Therefore, resultant is outside the middle third of the mat.

$$(4' - 2.4') \times 3 = 4.8 \text{ ft}$$

$$\text{S.P.} = (74 \text{ k})(2)/(4.8 \text{ ft})(8 \text{ ft}) = 3850 \text{ psf} < 4000 \text{ psf}$$

$$M_R = (74 \text{ k})(4 \text{ ft}) = 296 \text{ k-ft}$$

$$M_R/M_o = 296/175 = 1.7$$

FOS against overturning, O.K.

Method 2 (increase mat size to keep the resultant in the middle third) Try a 11.3 ft x 11.3 ft mat

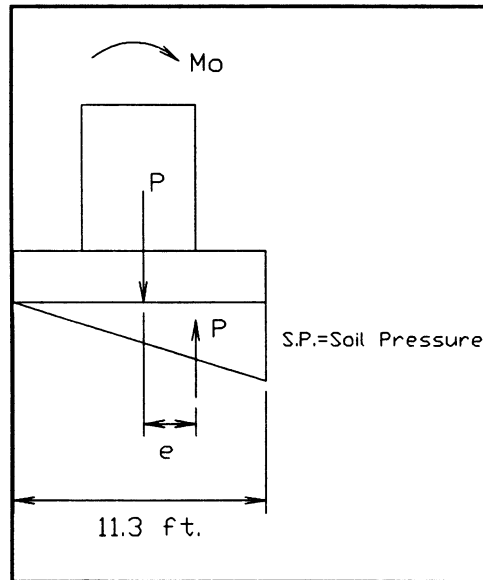

$$P \text{ increase} = [(11.3 \text{ ft})^2 - (8 \text{ ft})^2] \times 0.3 \text{ k/ft}^2 = 19.1 \text{ kips}$$

$$e = 175 \text{ k-ft}/(74 + 19.1) \text{ kips} = 1.88 \text{ ft} = 11.3 \text{ ft}/6$$

Resultant is within middle third.

$$\text{S.P.} = (93.1 \text{ k})(2)/(11.3)^2 = 1460 \text{ lbs/ft}^2 < 4000 \text{ lbs/ft}^2$$

Therefore, O.K.

$$\text{Increase in mat size} = (11.3/8)^2 = 1.99$$

Therefore, mat size has doubled, assuming that the mat thickness remains the same.

EXAMPLE 15.5: Design of a Drilled Shaft

Problem—Determine the depth of a 5-ft diameter drilled shaft in cohesive soil with a cohesion of 1.25 ksf by both Broms and modified Broms methods. The foundation is subjected to a combined moment of 2000 ft-k and a shear of 20 kips under extreme wind loading. Manual calculation by Broms method is shown herein while the modified Broms method is made by the use of a computer program (CADPRO) [25], which determines the depth required, lateral displacement, and rotation of the foundation top. Calculations are made for various factors of safety (or strength reduction factor). The equations used in this example are based on Reference [25].

Foundation in Cohesive Soil:

$$M = 2000 \text{ ft-kips}$$

$$V = 20 \text{ kips}$$

Cohesion:

$$C = 1.25 \text{ ksf}$$

$$D = 5'$$

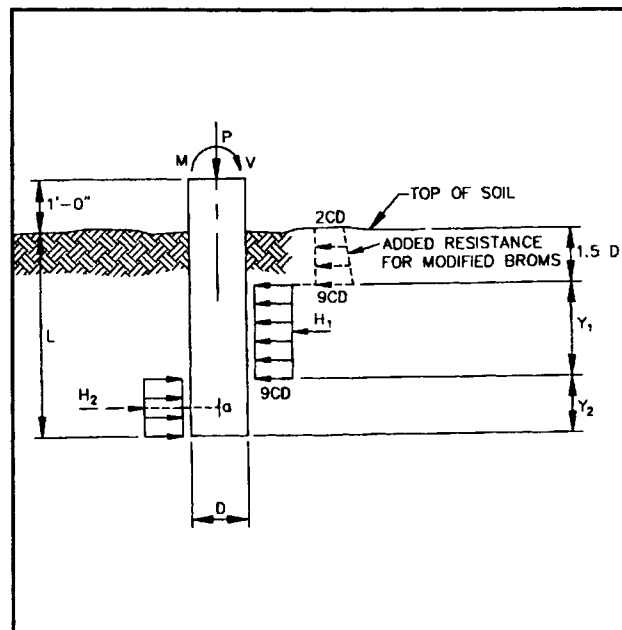

Solution

1. Use Broms Method [14]

$$M = 2000 + 20 \times 1$$

$$= 2020 \text{ ft-k}$$

$$H = M/V = 2020/20 = 101$$

$$\begin{aligned}
 q &= V/(9CD) = 20/(9)(1.25)(5) = 0.356 \\
 L &= 1.5D + q \left[1 + (2 + (4H + 6D)/q)^{0.5} \right] \\
 &= (1.5)(5) + .356 \left[1 + (2 + (4)(101) + (6)(5))/0.356 \right]^{0.5} = 20.3 \text{ ft}
 \end{aligned}$$

2. Comparison of Results of Broms Method and Modified Broms Method.

FOS	Φ	C used	Depth from broms (ft)	Modified Brom		
				D (ft)	Δ	θ
1.0	1.0	1.25	20.3	19	.935	.457
1.33	0.75	.9375	22.3	19.5	.89	.474
1.5	0.667	.833	23.2	20.5	.81	.366
1.75	0.575	.714	24.6	23.0	.653	.262
2.0	0.5	.625	25.8	24.0	.603	.23

where

- FOS* = factor of safety
 Φ = strength reduction factor
 Δ = displacement, in.
 θ = rotation, degrees

3. Conclusions

This example demonstrates that the modified Broms method provides a more economical design than the Broms method. It also shows that as the depth increases by 26%, the factor of safety increased from 1.0 to 2.0. The cost will also increase proportionally.

15.6 Defining Terms

Bearing connection: Shear resistance is provided by bearing of bolt against the connected part.

Block shear: A combination of shear and tensile failure through the end connection of a member.

Buckling: Mode of failure of a member under compression at stresses below the material yield stress.

Cascading effect: Progressive failure of structures due to an accident event.

Circuit: A system of usually three phase conductors.

Eccentric connection: Lines of force in intersecting members do not pass through a common work point, thus producing moment in the connection.

Galloping: High amplitude, low frequency oscillation of snow covered conductors due to wind on uneven snow formation.

Horizontal span: The horizontal distance between the midspan points of adjacent spans.

Leg and bracing members: Tension or compression members which carry the loads on the structure to the foundation.

Line angle: Denotes the change in the direction of a transmission line.

Line tension: The longitudinal tension in a conductor or shield wire.

Longitudinal load: Load on the supporting structure in a direction parallel to the line.

Overload capacity factor: A multiplier used with the unfactored load to establish the design factored load.

Phase conductors: Wires or cables intended to carry electric currents, extending along the route of the transmission line, supported by transmission structures.

Redundant member: Members that reduce the embraced length of leg or brace members by providing intermediate support.

Sag: The distance measured vertically from a conductor to the straight line joining its two points of support.

Self supported structure: Unguyed structure supported on its own foundation.

Shear friction: A mechanism to transfer the shear force at anchor bolts to the concrete through wedge action and tension of anchor.

Shield wires: Wires installed on transmission structures intended to protect phase conductors against lightning strokes.

Slenderness ratio: Ratio of the member unsupported length to its least radius of gyration.

Span length: The horizontal distance between two adjacent supporting structures.

Staggered bracing: Brace members on adjoining faces of a lattice tower are not connected to a common point on the leg.

Stringing: Installation of conductor or shield wire on the structure.

Transverse load: Load on the supporting structure in a direction perpendicular to the line.

Uplift load: Vertically upward load at the wire attachment to the structure.

Vertical span: The horizontal distance between the maximum sag points of adjacent spans.

Voltage: The effective potential difference between any two conductors or between a conductor and ground.

References

- [1] ACI Committee 318, 1995, *Building Code Requirements for Reinforced Concrete with Commentary*, American Concrete Institute (ACI), Detroit, MI.
- [2] ANSI, 1979, *Specification and Dimensions for Wood Poles*, ANSI 05.1, American National Standard Institute, New York.
- [3] ANSI/ASCE, 1991, *Design of Steel Latticed Transmission Structures*, Standard 10-90, American National Standard Institute and American Society of Civil Engineers, New York. (Former ASCE Manual No. 52).
- [4] ANSI/IEEE, 1992, *IEEE Guide to the Installation of Overhead Transmission Line Conductors*, Standard 524, American National Structure Institute and Institute of Electrical and Electronic Engineers, New York.
- [5] ANSI/IEEE, 1993, *National Electrical Safety Code*, Standard C2, American National Standard Institute and Institute of Electrical and Electronic Engineers, New York.
- [6] ASCE, 1984, *Guideline for Transmission Line Structural Loading*, Committee on Electrical Transmission Structures, American Society of Civil Engineers, New York.
- [7] ASCE, 1986, Innovations in the Design of Electrical Transmission Structures, *Proc. Conf. Struct. Div. Am. Soc. Civil Eng.*, New York.
- [8] ASCE, 1987, *Guide for the Design and Use of Concrete Pole*, American Society of Civil Engineers, New York.
- [9] ASCE, 1990, *Design of Steel Transmission Pole Structures*, ASCE Manual No. 72, Second ed., American Society of Civil Engineers, New York.
- [10] CSI, 1992, *SAP90—A Series of Computer Programs for the Finite Element Analysis of Structures—Structural Analysis User's Manual*, Computer and Structures, Berkeley, CA.
- [11] EPRI, 1983, *Transmission Line Structure Foundations for Uplift-Compression Loading: Load Test Summaries*, EPRI Report EL-3160, Electric Power Research Institute, Palo Alto, CA.

- [12] EPRI, 1990, *T.L. Workstation Code*, EPRI (Electric Power Research Institute), Report EL-6420, Vol. 1-23, Palo Alto, CA.
- [13] Gere, J.M. and Carter, W.O., 1962, Critical Buckling Loads for Tapered Columns, *J. Struct. Div.*, ASCE, 88(ST1), 112.
- [14] IEEE, 1985, *IEEE Trial-Use Guide for Transmission Structure Foundation Design*, Standard 891, Institute of Electrical and Electronics Engineers, New York.
- [15] IEEE, 1991, *IEEE Trial-Use Guide for Wood Transmission Structures*, IEEE Standard 751, Institute of Electrical and Electronic Engineers, New York.
- [16] Kramer, J. M., 1978, Direct Embedment of Transmission Structures, Sargent & Lundy Transmission and Substation Conference, Chicago, IL.
- [17] Peyrot, A.H., 1985, Microcomputer Based Nonlinear Structural Analysis of Transmission Line Systems, *IEEE Trans. Power Apparatus and Systems*, PAS-104 (11).
- [18] REA, 1980, *Design Manual for High Voltage Transmission Lines*, Rural Electrification Administration (REA) Bulletin 62-1.
- [19] REA, 1992, Design Manual for High Voltage Transmission Lines, Rural Electrification Administration (REA), Bulletin 1724E-200.
- [20] REI, 1993, *Program STAAD-III—Structural Analysis and Design—User's Manual*, Research Engineers, Orange, CA.
- [21] Rossow, E.C., Lo, D., and Chu, S.L., 1975, Efficient Design-Analysis of Physically Nonlinear Trusses, *J. Struct. Div.*, 839-853, ASCE, New York.
- [22] Roy, S., Fang, S., and Rossow, E.C., 1982, Secondary Effects of Large Deflection in Transmission Tower Structures, *J. Energy Eng.*, ASCE, 110-2, 157-172.
- [23] Roy, S. and Fang, S., 1993, Designing and Testing Heavy Dead-End Towers, *Proc. Am. Power Conf.*, 55-I, 839-853, ASCE, New York.
- [24] Simpson, K.D. and Yanaga, C.Y., 1982, Foundation Design Considerations for Transmission Structure, Sargent & Lundy Transmission and Distribution Conference, Chicago, IL.
- [25] Simpson, K.D., Strains, T.R., et. al., 1992, Transmission Line Computer Software: The New Generation of Design Tool, Sargent & Lundy Transmission and Distribution Conference, Chicago, IL.