

## Unit 14

# TRANSFORMERS

### OBJECTIVES

After studying this unit, the student will be able to

- state the purpose of a transformer.
- explain the principle of mutual induction.
- determine the output voltage of a transformer if the input voltage and turns ratio are known.
- determine the full-load current of a transformer given the kVA and voltages of the primary and secondary windings.
- identify the common types of transformers from their schematic diagrams.
- read transformer winding diagrams and connect a transformer for the desired primary and secondary voltage.
- choose the proper transformer taps to obtain the desired output voltage.
- connect buck and boost transformers to obtain desired voltage for a single-phase application.
- choose the correct transformer kVA for the application, given the voltage, current, and phase requirement of a load.
- size overcurrent protection for dry-type transformers operating at 600 V or less.
- size the feeder conductor for the transformer and wires from the transformer to loads.
- properly ground a transformer, and the secondary electrical system produced by the transformer.

The purpose of a transformer is to change electrical voltage to a different value. For example, a farmer has a large, 480-V, 3-phase motor powering a well. The motor is in a building, and the farmer wants one 120-V circuit

for a few lights and a receptacle outlet. A transformer is used to lower the voltage from 480 V to 120 V for the lighting circuit, Figure 14-1. The controls for furnaces and air-conditioning units are often operated at 24 V,

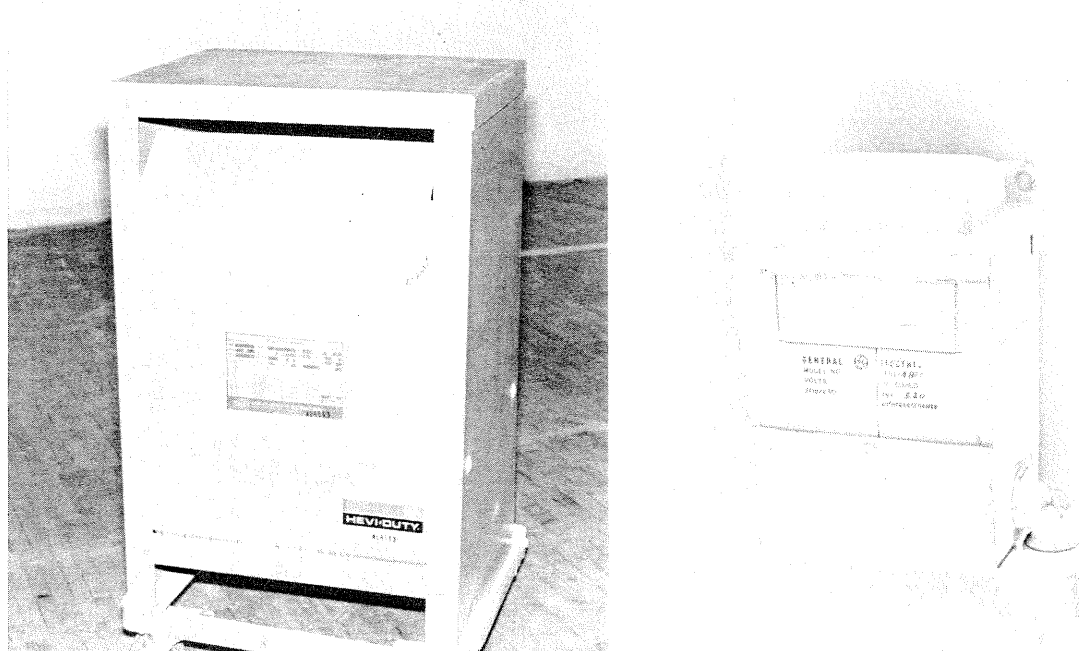

Figure 14-1 Dry-type transformers

Figure 14-2. A small transformer inside the equipment lowers the line voltage to 24 V for the control circuit. Transformers are frequently used inside electronic equipment.

## HOW THE TRANSFORMER WORKS

A clear understanding of how transformers work is necessary in order to wire them properly in an electrical system. Understanding input and output current and grounding are particularly troublesome. A dual-voltage transformer can be ruined when power is applied, if the connections are made improperly.

An important property of electricity is that a magnetic field is produced around a wire in which electrical current is flowing, Figure 14-3. The more current that flows, the stronger is the magnetic field. An even stronger magnetic field can be produced by winding the wire into a coil. Now the magnetic fields of adjacent wires add together to form one strong magnetic field.

The electrical current flowing in a transformer is alternating current. The current flows first in one direction, stops, then reverses and flows in the other direc-

tion. The magnetic field around the winding is constantly in motion. Figure 14-4 shows the magnetic field during one cycle. Notice that the north and south poles of the magnetic field reverse when the flow of current reverses.

Another property of electricity is important to the operation of a transformer. When a magnetic field moves across a wire, a voltage is induced into the wire, Figure 14-5. If the wire forms a complete circuit, current will flow in the wire. If a second coil of wire is placed in a moving magnetic field, then a voltage will be induced in this second coil, Figure 14-6. This phenomenon is called *mutual induction*. Alternating current in one winding produces a moving magnetic field that induces a voltage in a second winding. Electrical energy is converted into a magnetic field and then converted back into electrical energy in a second winding. The trick is to do this with little or no loss of energy.

The magnetic field loses strength quickly in air therefore, a special steel core is used. The core is composed of thin sheets of a silicon-steel alloy. The magnetic field is concentrated in the core, and energy losses are reduced to a minimum. Figure 14-6 shows the two windings separated. Most transformers have one winding placed directly over the other to further reduce the loss of energy, as shown in Figure 14-7.

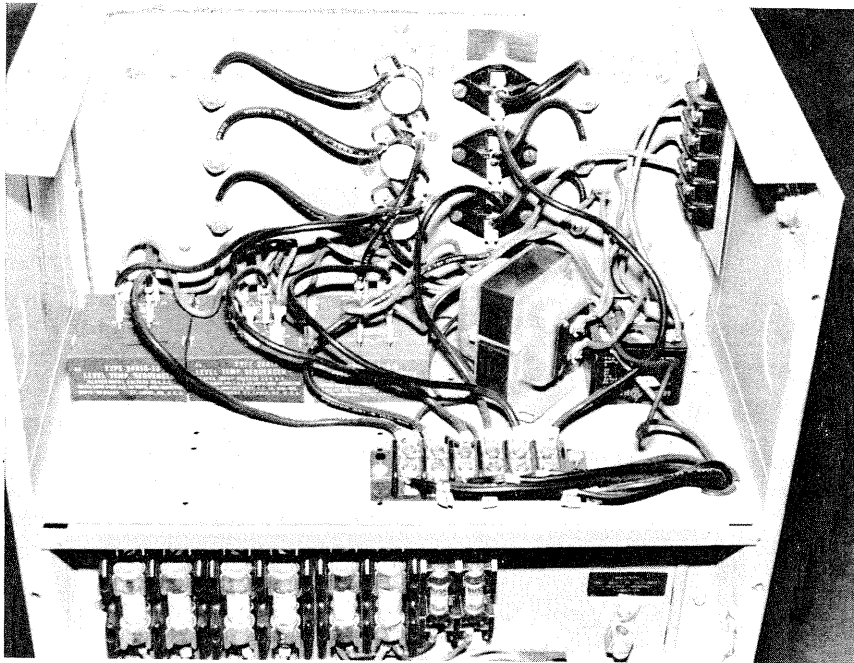

Figure 14-2 Control transformers are common in appliances and electrical equipment.

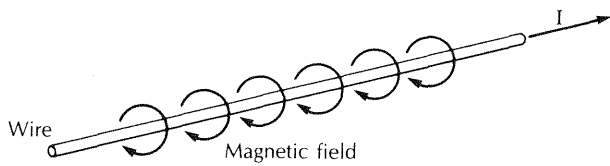

Figure 14-3 When electrical current flows through a wire, a magnetic field is built up around the wire.

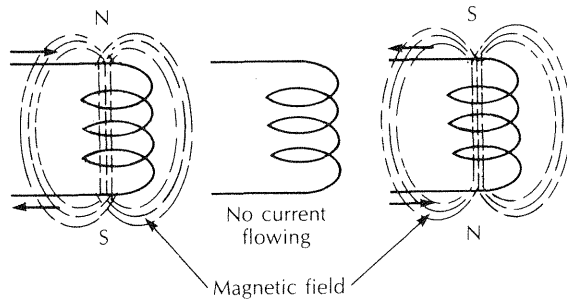

Figure 14-4 When alternating current is flowing in the coil, the magnetic field is constantly moving. (The arrows indicate electron flow.)

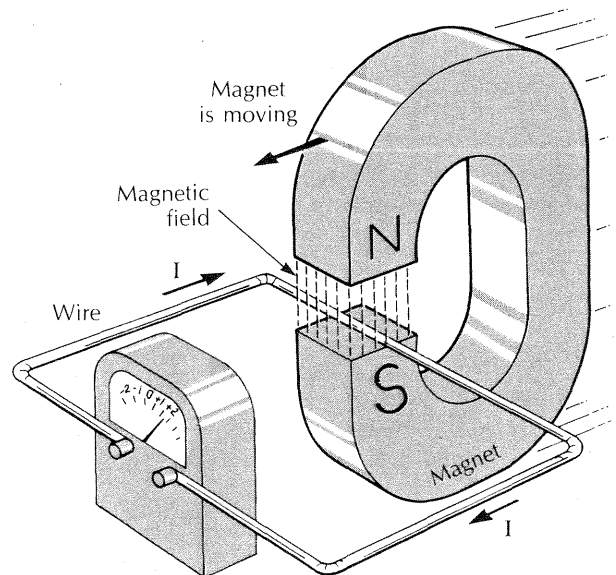
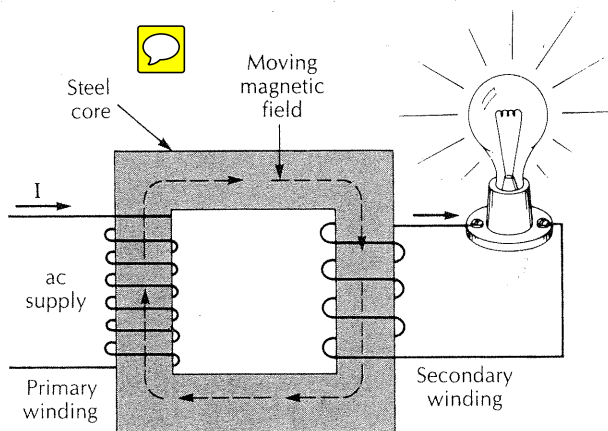
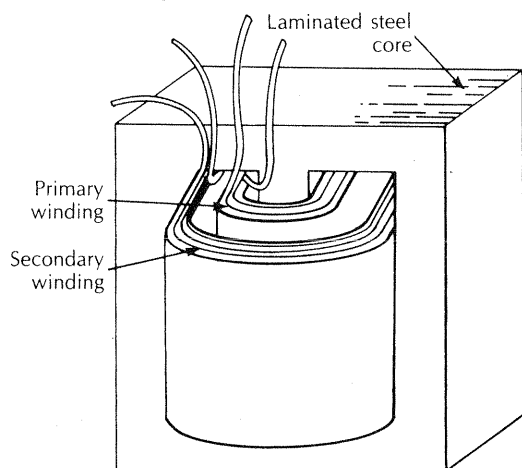

Figure 14-5 When the magnetic field moves across this wire, an electrical current flows in the wire.



**Figure 14-6** The two transformer windings are on separate parts of the silicon-steel core.



**Figure 14-7** In most transformers, the two windings are placed one over the other to reduce energy losses.

## VOLTAGE AND TURNS RATIO

The input winding to a transformer is called the **primary winding**. The output winding is called the **secondary winding**. If there are more turns of wire on the primary than on the secondary, the output voltage will be lower than the input voltage. This is illustrated in Figure 14-8 for a step-down and a step-up transformer. Notice that the winding with the greater number of turns has the higher voltage. In Figure 14-8, one winding has twice as many turns as the other. In one case the voltage is stepped down to half, while in the other the voltage is stepped up to double.

It is important to know the ratio of the number of turns of wire on the primary winding as compared to the secondary winding. This is called the **turns ratio** of the transformer, Equation 14.1. The actual number of turns is not important, just the turns ratio.

$$\begin{aligned} \text{Turns ratio} & \qquad \qquad \qquad \text{Eq. 14.1} \\ & = \frac{\text{Number of turns on the primary}}{\text{Number of turns on the secondary}} \end{aligned}$$

The step-down transformer of Figure 14-8 has 14 turns on the primary, and 7 turns on the secondary; therefore, the turns ratio is 2 to 1, or just 2. The step-up transformer has 7 turns on the primary and 14 on the secondary; therefore, the turns ratio is 1 to 2, or 0.5. If one voltage and the turns ratio are known, the other voltage can be determined with Equations 14.2 or 14.3.

$$\begin{aligned} \text{Primary voltage} & \qquad \qquad \qquad \text{Eq. 14.2} \\ & = \text{Secondary voltage} \times \text{turns ratio} \end{aligned}$$

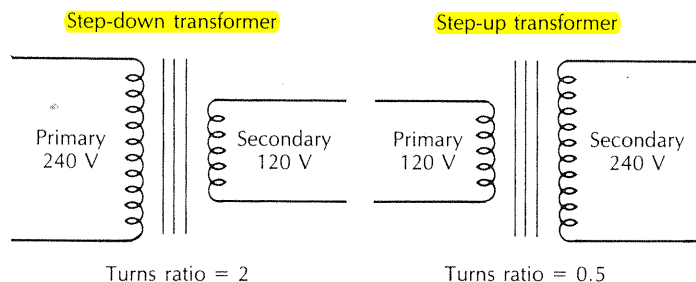

**Figure 14-8** Schematic diagrams of step-down and step-up transformers.

$$\text{Secondary voltage} = \frac{\text{Primary voltage}}{\text{Turns ratio}} \quad \text{Eq. 14.3}$$

Use these equations to verify the voltages in Figure 14-8.

### Problem 14-1

A step-down transformer has a turns ratio of 4 to 1 or 4. If the transformer secondary voltage is 120 V, determine the primary voltage.

### Solution

Use Equation 14.2 to solve for the primary voltage.

$$\text{Primary voltage} = 120 \text{ V} \times 4 = 480 \text{ V}$$

The turns ratio tells us that the primary voltage is four times as great as the secondary voltage.

## TRANSFORMER RATINGS

Transformers are rated in volt-amperes (VA) or kilovolt-amperes (kVA). This means that the primary and the secondary winding are designed to withstand the VA or kVA rating stamped on the transformer nameplate. The primary and secondary full-load currents usually are not given. The installer must be able to calculate the primary and secondary currents from the nameplate information.

When the volt-ampere (or kilovolt-ampere) rating is given, along with the primary voltage, then the primary full-load current can be determined, using Equation 14.4 (for a single-phase transformer) or Equation 14.5 (for a 3-phase transformer).

Single phase:

$$\text{Full-load current} = \frac{\text{VA rating}}{\text{Voltage}} \quad \text{Eq. 14.4}$$

or

$$\text{Full-load current} = \frac{\text{kVA} \times 1\,000}{\text{Voltage}}$$

Three phase:

$$\text{Full-load current} = \frac{\text{VA rating}}{1.73 \times \text{Voltage}} \quad \text{Eq. 14.5}$$

or

$$\text{Full-load current} = \frac{\text{kVA} \times 1\,000}{1.73 \times \text{Voltage}}$$

### Problem 14-2

A single-phase transformer with a 2-kVA rating has a 480-V primary, and a 120-V secondary. Determine the primary and secondary full-load currents of the transformer.

### Solution

Use Equation 14.5 to solve for both primary and secondary currents.

$$\begin{aligned} \text{Primary full-load current} &= \frac{2 \text{ kVA} \times 1\,000}{480 \text{ V}} = 4.17 \text{ A} \\ \text{Secondary full-load current} &= \frac{2 \text{ kVA} \times 1\,000}{120 \text{ V}} = 16.67 \text{ A} \end{aligned}$$

It may seem strange at first, but the transformer current will be higher in the winding which produces the lower voltage. This concept is important to understand in order to avoid transformer or conductor overloading. The primary and secondary transformer full-load currents are also related by the turns ratio, as shown in Equation 14.6.

$$\text{Primary full-load current} = \frac{\text{Secondary full-load current}}{\text{Turns ratio}} \quad \text{Eq. 14.6}$$

## TYPES OF TRANSFORMERS

Transformers are of the *dry type* or *oil filled*. From 2% to 5% of the electrical energy is lost in a transformer, mostly due to the *resistance* of the windings. Large transformers *circulate oil through the windings to remove the heat*. Dry transformers use *air for cooling*. Heat is moved from the windings to the case by conduction in smaller sizes of the dry type. Large dry-type transformers actually allow air to circulate through the windings, Figure 14-9. *Oil-filled transformers are used by the electric utility, and for industrial or large commercial applications.*

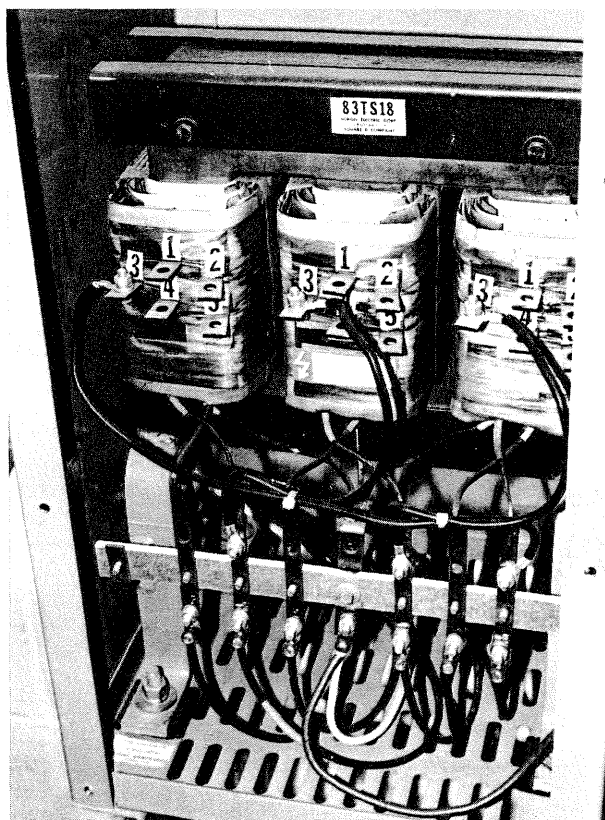

**Figure 14-9** Air can circulate around and through the windings of a large, dry-type transformer.



Transformers installed for applications on a farm electrical system are almost always dry-type transformers. Only dry-type transformers operating at less than 600 V are discussed in this unit.

**Common two-winding transformers** are often called **insulating transformers**. The **primary winding** and the **secondary winding** are separate and not connected. An **autotransformer** has its **windings interconnected** so that the primary and the secondary share the same windings. Autotransformers, therefore, have an electrically connected primary and secondary. These two basic types of transformers are shown in Figure 14-10. A major advantage of autotransformers over the insulating types is their lighter weight and compact size. Autotransformers are used for electric-discharge lighting ballasts.

**A special type of autotransformer, called a grounding autotransformer or zigzag transformer, is occasionally used to create a neutral wire or a ground for an ungrounded 480-V, 3-phase system.** These transformers are found occasionally in industrial wiring. Standard in-

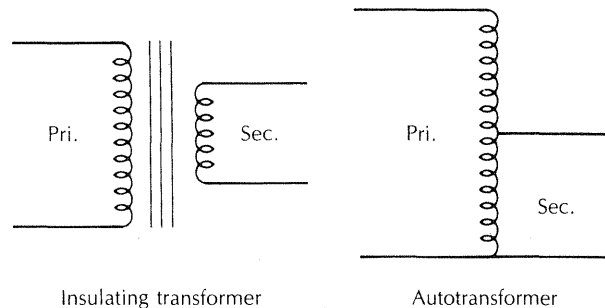

**Figure 14-10** Two basic types of transformers are the insulating transformer and the autotransformer.

ulating transformers can be used to make a zigzag transformer. The wiring of these transformers is covered in *NEC Section 450-5*.

**Control transformers** are special insulating transformers commonly used to supply power for control of appliances, equipment, and **motor starters**, Figure 14-11. A control transformer is required when the control circuit voltage is different from the line voltage supplied. Common control circuit voltages are 24 V and 120 V. A 120-V control circuit to a start-stop push-button station may be desirable for a 125-hp, 480-V, 3-phase motor powering an irrigation pump. The control transformer would step down the 480 V to 120 V for the control circuit.

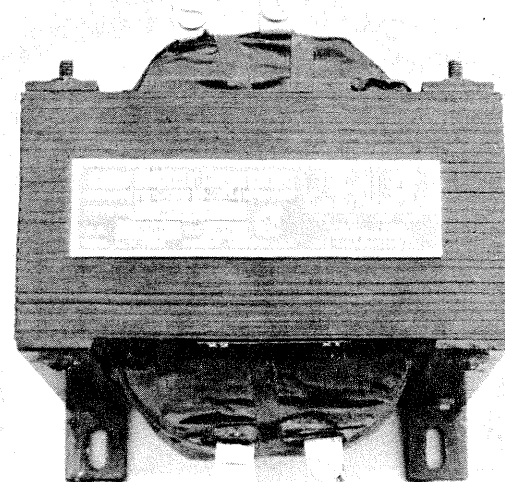

**Figure 14-11** Control transformers are commonly used in appliances, equipment, and motor starters.

**Control transformers** are designed to withstand **short-duration overloads** with minimal output voltage drop. **Motor starter** solenoid coils draw **six to eight** times as much current when they are closing as is required to hold them closed.

**Constant output voltage** transformers or voltage regulating transformers produce a nearly constant output voltage, even though the input voltage may not be constant. The voltage supplied by the utility typically will fluctuate up and down a few percent during the day. This voltage fluctuation is of little concern except for certain equipment, such as **electronic computers**. Installing a constant output voltage transformer to supply **sensitive equipment** will eliminate undesirable voltage fluctuations. Special filters can also be added to these transformers to **eliminate voltage spikes** and **electrical noise** caused by other equipment operating on the electrical system, Figure 14-12.

## CONNECTING TRANSFORMER WINDINGS

Transformer wiring diagrams are printed on the transformer nameplate which may be affixed to the outside of the transformer or printed inside the cover to the wiring compartments. The lead wires or terminals are marked with the letters H and X. Those lettered H are the

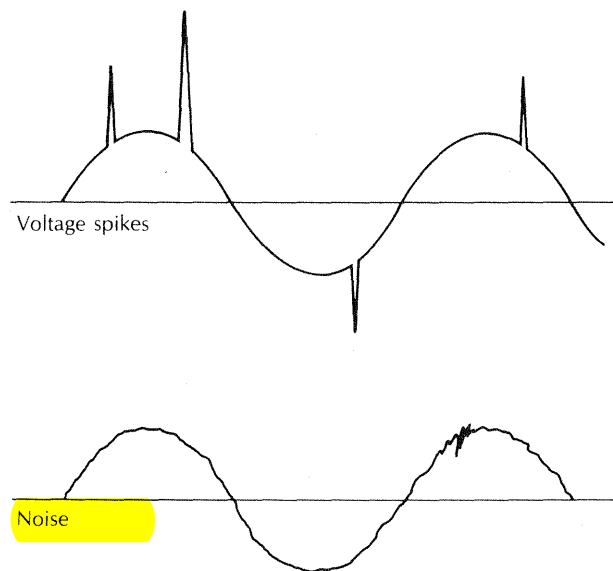

**Figure 14-12** Voltage spikes and noise distort the normal alternating-voltage sine wave.

primary (high-voltage) leads, and those lettered X are the secondary (low-voltage) leads.

Some transformers have **two primary and two secondary windings** (as shown in Figure 14-13) so they can be used for several applications. These are called **dual-voltage transformers**. Connections must be made correctly with dual-voltage transformers. If connected improperly, it is possible to create a dead short that will usually ruin the transformer when it is energized.

Consider a dual-voltage transformer rated at 240/480 V on the primary, and 120/240 V on the secondary. Each of the two primary windings is, therefore, rated at 240 V. Each secondary winding is rated at 120 V. The transformer must be connected so that each primary winding receives the proper voltage. In Figure 14-13, the transformer is shown with the primary windings connected in series, with H1 and H4 connected to a 480-V supply. The voltage across H1 and H2 is 240 V and the voltage across H3 and H4 is 240 V. Each winding is receiving the proper voltage. With each primary winding receiving the proper 240 V, each secondary winding will have an output of 120 V. Connecting the secondary windings in series produces 240 V across X1 and X4.

Now consider a case where the primary voltage available is 480 V, but the desired output is 120 V. In this case, the primary windings are connected in series, as in Figure 14-13. The secondary windings are, however, connected in parallel, Figure 14-14. This is accomplished by connecting X1 to X3, and X2 to X4. If this is not done properly, a 240-V dead short will occur. A voltmeter can be used to make sure the connection is correct. Connect X1 to X3, and then connect a voltmeter between X2 and X4. Energize the primary and read the

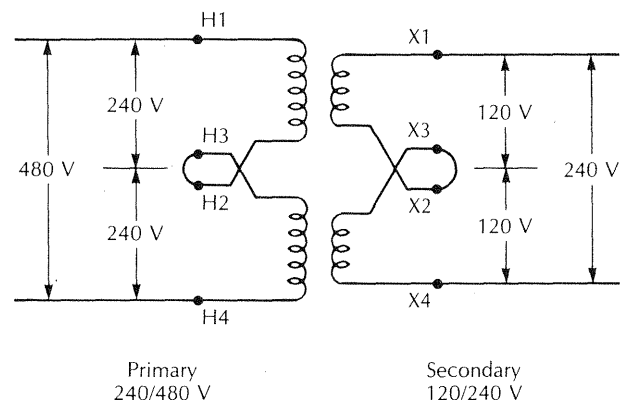

**Figure 14-13** The windings are connected in series to obtain the higher of the rated transformer voltages.

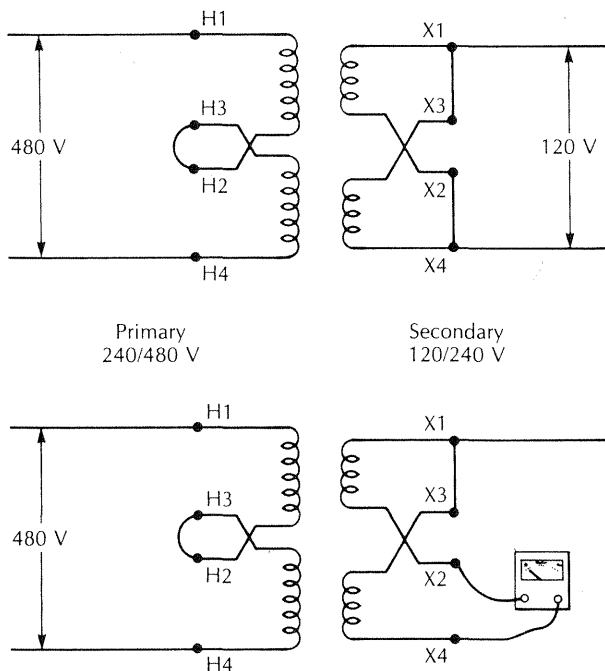

**Figure 14-14** The secondary windings are connected in parallel for an output of 120 V. A voltmeter can be used to make sure the transformer is connected properly.

voltmeter. If the connection is correct, the voltmeter will read zero. If the voltmeter reads something other than zero, check all primary and secondary connections to make sure they are connected exactly as indicated by the manufacturer.

The primary on the example transformer has two windings; therefore, it can also be connected for a 240-V supply. The primary windings must be placed in parallel by connecting H1 to H3 and H2 to H4. If this is not done as indicated on the transformer nameplate, the magnetic fields created by each winding will oppose each other. The magnetic fields work together when the windings are properly placed in parallel.

### THREE-PHASE TRANSFORMERS

Changing the voltage of a 3-phase system can be done with a 3-phase transformer or with single-phase transformers. Three-phase transformers are generally designed and constructed for specific voltages. For example, a transformer may have a 480-V delta primary and a 120/208-V wye secondary. A typical nameplate for this type of transformer is shown in Figure 14-15.

The 3-phase transformer has one core with three sets of windings. A primary and a secondary winding are

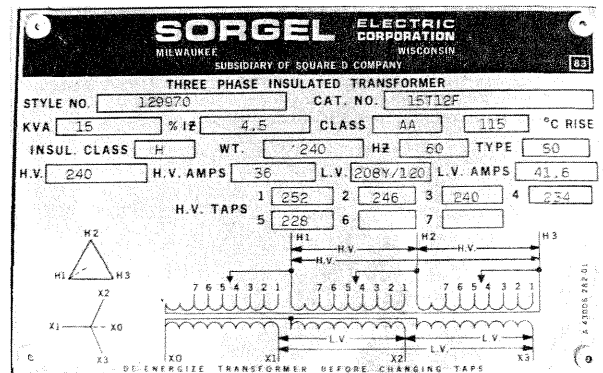
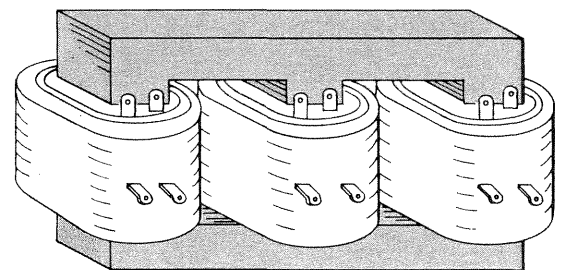

**Figure 14-15** Nameplate of a 3-phase transformer

placed one on top of the other on each of the three legs of the core, Figure 14-16. The secondary windings are connected in either wye or delta, as required by the load to be supplied. The primary is connected in wye or delta, depending upon the type of electrical system available. Common 3-phase transformer connections, listing primary windings first, are: delta-delta, wye-delta, and delta-wye. A wye-wye connection is usually not recommended. In a wye-wye connection, a third harmonic current may occur, causing possible current overloading and damage to the primary neutral wire. A delta-wye transformer can usually be substituted. Always be sure to consult the transformer manufacturer before installing a wye-wye connection.

### Problem 14-3

A building is supplied with a 480-V, 3-phase electrical system. Many 120-V circuits are needed; therefore, it is decided to use a 3-phase transformer to step down the voltage to supply a 100-A, 120/208-V panelboard. Which of the following transformers is suitable for this application: a delta-delta, a wye-delta, or a delta-wye?



**Figure 14-16** Three-phase transformer construction



## Solution

A 120/208-V system is a wye system. Therefore, the secondary must be wye connected. Usually, it does not matter if the supply system is wye or delta connected. A wye-wye connection is not recommended; therefore, a delta-wye is a likely choice. It is always best, however, to consult a transformer manufacturer's representative to make sure the most appropriate transformer is selected for an application.

Single-phase transformers can be used to form a 3-phase transformer bank. It is important that single-phase transformers are identical when connecting them to form a 3-phase system. They should be identical in voltage, kVA, impedance, manufacturer, and model number. Transformer *impedance* is the combined effect of resistance and inductance, and is given in percent.

Connecting single-phase transformers to form a 3-phase bank must be done with *extreme caution*. It is essential that the windings be connected in a certain way only. Reversing a winding can damage the transformer. Figure 14-17 shows three individual single-phase trans-

formers connected to step down 480-V delta to 240-V delta. It is best to obtain a 3-phase transformer rather than to try to connect single-phase transformers. To illustrate the complexity, standard dual-voltage, single-phase transformers are used to change a 480-V, 3-phase delta to a 120/208-V 3-phase wye in Figure 14-18.

## WINDING TAPS

Transformers, except for small sizes, are often supplied with winding taps to compensate for abnormally low or high primary voltage. Assume, for example, that a transformer is rated 480 V primary and 240 V secondary. This means that 240 V will be the output if the input is 480 V. But, what if the input is only 444 V? The turns ratio for this transformer is 2 to 1; therefore, using Equation 14.3, the output will be 222 V.

$$\text{Secondary voltage} = \frac{444 \text{ V}}{2} = 222 \text{ V}$$

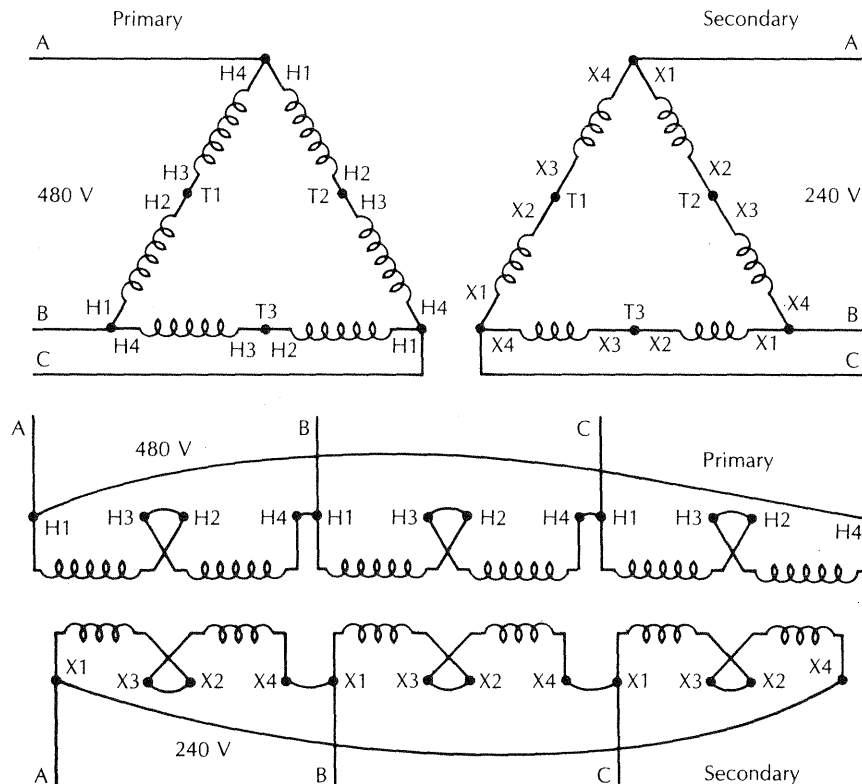
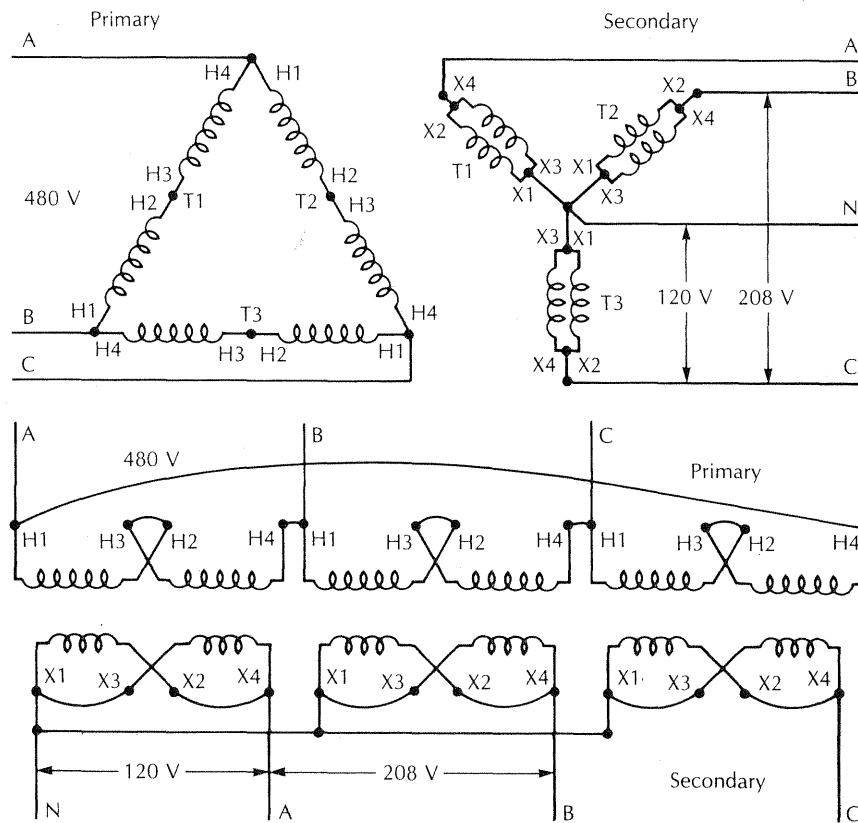

Figure 14-17 Dual-voltage, single-phase transformers with 240/480-V primary windings, and 120/240-V secondary windings are shown connected to form a 480-V delta to 240-V delta, 3-phase, step-down transformer bank.



**Figure 14-18** Dual-voltage, single-phase transformers with 240/480-V primary windings, and 120/240-V secondary windings are shown connected to form a 480-V delta to 120/208-V wye, 3-phase, step-down transformer bank.

In order to get an output of 240 V with an input of only 444 V, the turns ratio will have to be changed to 1.85 to 1. The purpose of the tap connections, usually on the primary, is to change easily the transformer turns ratio. A typical single-phase transformer nameplate with primary taps is shown in Figure 14-19.

Winding taps each make a 2½% change in the voltage. A transformer will often have two taps above normal voltage and four taps below normal voltage. A transformer usually comes preconnected for normal voltage. If an abnormal voltage is present, it is up to the installer to change the tap connections.

### Problem 14-4

A 25-kVA, single-phase transformer is used to supply 120/240 V, 3 wires, to a 100-A panelboard. The primary voltage is only 450 V instead of the normal 480 V. Show how to connect the transformer of Figure 14-19 to compensate for the low input voltage.

### Solution

The primary windings must be connected in series because the normal voltage should be 480 V. Therefore check the transformer nameplate for series tap connections. Move down the voltage column until the actual input voltage fits between two numbers. Usually, the higher voltage on the chart is used. If the lower number is used, the output will be greater than 240 V. The proper connection is shown in Figure 14-20 with jumper wire placed between taps 5 and 6. If the input had been 480 V, the jumper would have been between taps and 4.

Assume that the input is 225 V and the desired output is 120 V. This requires the primary windings to be placed in parallel. This time, the parallel high-voltage tap connection chart on the nameplate is used. Mark the location on the chart where the actual input voltage fits. Then take the next higher tap connection on the chart. Figure 14-21 shows the proper connection.

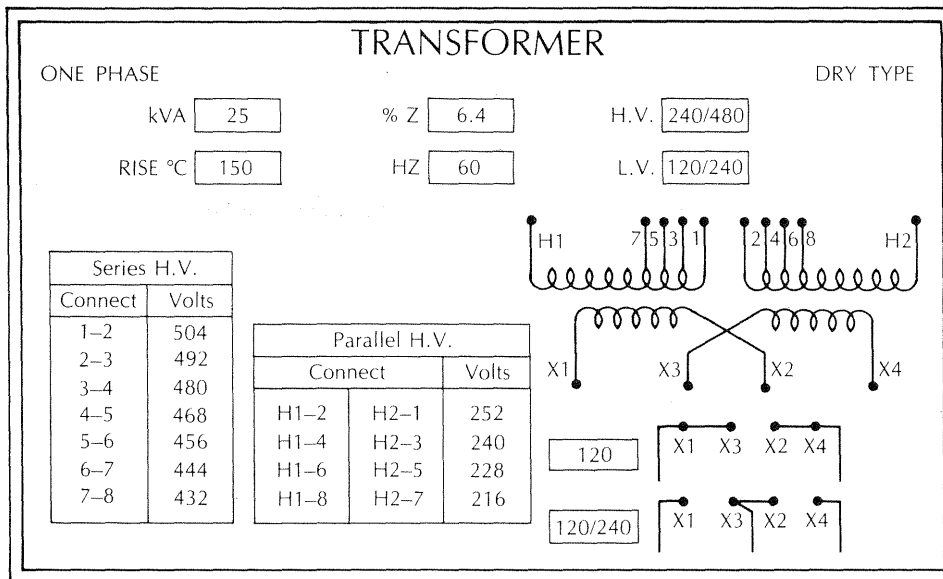

Figure 14-19 Nameplate of a single-phase transformer with primary taps.

## BUCK AND BOOST TRANSFORMERS

A buck and boost transformer is an insulating transformer which can be connected as an autotransformer. The buck and boost transformer is used to make small adjustments in voltage either up or down. For example, a machine has an electric motor which requires 208 V, but the electrical supply is 240 V. If ordering the machine with a 240-V motor is expensive, a less costly solution to

the problem may be to buck the voltage from 240 V down to 208 V with a buck and boost transformer.

Low voltage resulting from voltage drop can be corrected with a buck and boost transformer, although this is not a good practice except in unusual circumstances. Voltage drop on wires is wasted energy and should be avoided.

Buck and boost transformers for single-phase applications have a dual-voltage primary rated at 120/240 V. A choice of two sets of secondary voltages is available, depending upon the amount of boosting or bucking required: 12/24 V and 16/32 V. Three-phase applications from 380 V to 500 V requires the use of a buck and boost transformer with a 240/480-V primary and a 24/48-V secondary. A typical buck and boost transformer is shown in Figure 14-22.

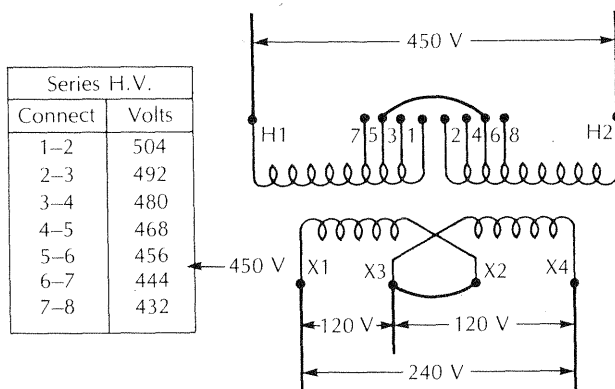

Figure 14-20 Single-phase transformer showing proper tap connection for an input of 450 V, and a 3-wire 120/240-V output.

A buck and boost transformer, when used as an autotransformer for bucking or boosting, can supply a load which requires several times the kVA rating of the transformer. The maximum kVA rating of the load supplied depends upon the full-load current rating of the transformer secondary and the operating voltage of the load. Each manufacturer supplies load current and kVA data for buck and boost transformers for all combinations of input and output voltages.

The manufacturer also supplies complete wiring diagrams for both single- and 3-phase applications. The

Parallel H.V.		
Connect		Volts
H1-2	H2-1	252
H1-4	H2-3	240
H1-6	H2-5	228
H1-8	H2-7	216

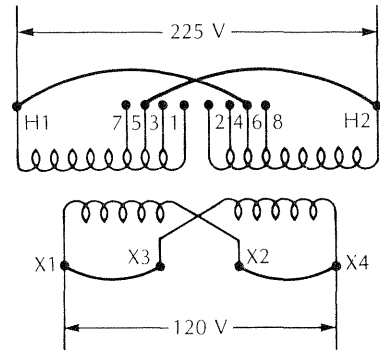

Figure 14-21 Single-phase transformer showing proper tap connection for an input of 225 V, and an output of 120 V

transformer of Figure 14-22 is shown boosting, and the transformer of Figure 14-23 is shown bucking.

known, the kVA can be calculated by using either Equation 14.7 or Equation 14.8.

### CHOOSING kVA RATING FOR THE LOAD

The kVA rating of a transformer for a particular application depends upon the phase, voltage, and current requirement of the load. With these three quantities

$$\text{Single-phase kVA} = \frac{\text{Volts} \times \text{Amperes}}{1\,000} \quad \text{Eq. 14.7}$$

$$\text{3-phase kVA} = \frac{1.73 \times \text{Volts} \times \text{Amperes}}{1\,000} \quad \text{Eq. 14.8}$$

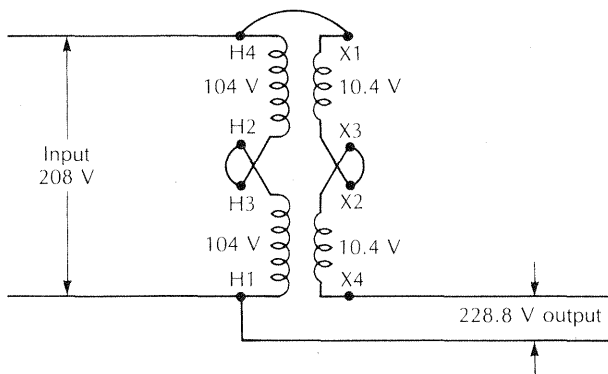
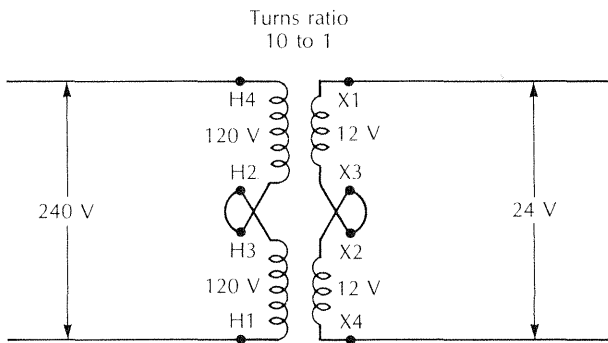

Figure 14-22 A buck and boost transformer connected as an insulating transformer to produce a 24-V output, and as an autotransformer to boost 208 V up to 228.8 V.

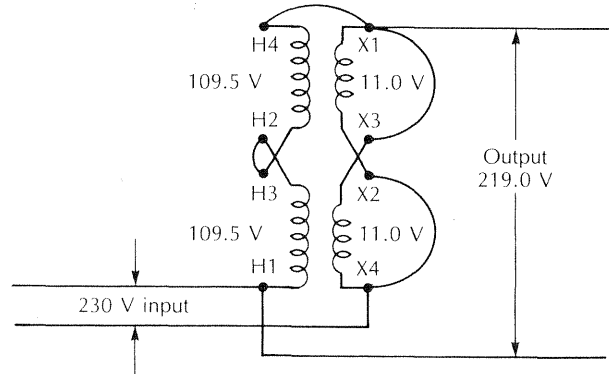

Figure 14-23 A buck and boost transformer with a 10 to turns ratio connected to buck 230 V down to 219 V. Note that the secondary winding is parallel connected.

The next standard transformer size larger than this minimum kVA requirement is chosen. In this example, a 25-kVA, single-phase transformer will be used. This could be the same as the transformer shown in Figure 14-19. Common transformer kVA ratings are shown in Table 14-1.

### Problem 14-5

A farm grain-drying and storage center is supplied with a 277/480-V, 3-phase system. Two 20-A, 120-V circuits are required for lights and receptacle outlets. Determine the minimum kVA rating of the single-phase, 480-V-to-120-V step-down transformer.

### Solution

Two 20-A circuits are required for a total load requirement of 40 A at 120 V. The minimum kVA requirement is determined by using Equation 14.7.

Table 14-1 Common transformer kVA ratings

Transformer kVA	
Single phase	Three phase
0.10	—
0.15	—
0.25	—
0.50	—
0.75	—
1	—
1.5	—
2	—
3	3
5	—
—	6
7.5	—
—	9
10	—
15	15
25	25
—	30
37.5	37.5
—	45
50	50
75	75
100	—
—	112.5
—	150
167	—
—	225
250	—
—	300
—	500
—	750
—	1 000

$$\text{Single-phase kVA} = \frac{120 \text{ V} \times 40 \text{ A}}{1\,000} = 4.8 \text{ kVA}$$

From Table 14-1, choose a 5-kVA, single-phase transformer.

### Problem 14-6

A machine has a 480-V, 3-phase electrical motor as an integral part of the machine. The total machine load requirement is 10 A at 480 V. If the building has a 240-V, 3-phase electrical system, determine the minimum-kVA 3-phase transformer required.

### Solution

The load requirement is 10 A, 480 V, 3 phase; therefore, use Equation 14.8.

$$\begin{aligned} \text{3-phase kVA} &= \frac{1.73 \times 480 \text{ V} \times 10 \text{ A}}{1\,000} \\ &= 8.3 \text{ kVA} \end{aligned}$$

From Table 14-1, choose a 9-kVA, 3-phase, 240-V-to-480-V step-up transformer.

Three single-phase transformers can be used to supply a 3-phase load. This is frequently the case when low kVA rating are required, such as in Problem 14-6. When single-phase transformers are used, the rating of each transformer must be not smaller than one-third the 3-phase kVA required. In Problem 14-6, the 3-phase load requirement is 8.3 kVA. Therefore, the single-phase transformer rating must be at least 2.8 kVA.

$$\frac{8.3 \text{ kVA}}{3} = 2.8 \text{ kVA}$$

The next larger common size single-phase transformer is 3 kVA. Therefore, three single-phase, 3-kVA, 240-V-to-480-V step-up transformers can be connected to form a 3-phase transformer bank. The transformer bank will have a 3-phase rating of 9 kVA.

## OVERCURRENT PROTECTION

Wiring a transformer circuit is one of the most difficult of wiring tasks, unless the installer understands transformer fundamentals. This unit deals with dry-type transformers operating at 600 V and less. Rules for siz-

ing overcurrent protection for this type of transformer are covered in *NEC Section 450-3(b)*. It must be noted that these rules apply only to the transformer itself, and not necessarily to the input and output circuit wires. Sizing and protecting transformer input and output wires is covered in the next section.

Three methods of providing overcurrent protection for transformers is covered by the *National Electrical Code*. Both the primary and the secondary windings must be protected. The procedure begins by calculating the primary and the secondary full-load current, using Equation 14.4 for single-phase transformers, and Equation 14.5 for 3-phase transformers.

A transformer can be protected by one overcurrent device on the primary side rated at not more than 1.25 (125%) times the primary full-load current, Figure 14-24. This overcurrent device can be a set of fuses in a panelboard, a fusible switch, or a circuit breaker.

Consider that a 25-kVA, single-phase transformer has a 480-V primary and a 120/240-V, 3-wire secondary. The primary full-load current is 52 A.

$\begin{aligned} \text{Primary full-load current} &= \frac{25 \text{ kVA} \times 1\,000}{480 \text{ V}} = 52 \text{ A} \\ \text{Maximum size overcurrent device} &= 52 \text{ A} \times 1.25 = 65 \text{ A} \end{aligned}$
--

The maximum size overcurrent device is 65 A. Checking a fuse catalog or *NEC Section 240-6*, 65 A is not a

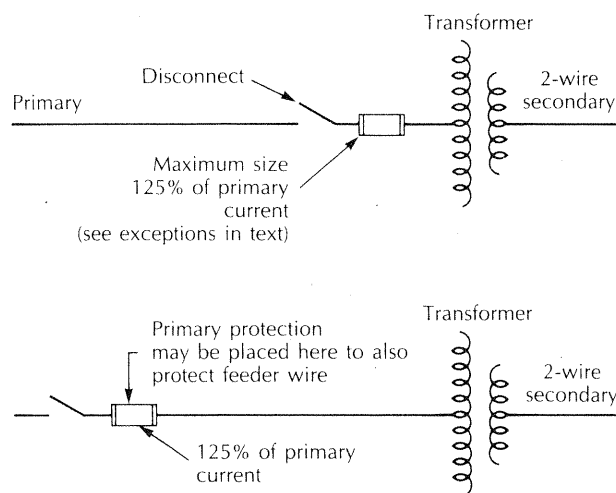

**Figure 14-24** A transformer may be protected with one overcurrent device on the primary, and sized at not more than 125% of the primary full-load current

standard size. However, *Exception No. 1* to *NEC Section 450-3(b)(1)* permits the next higher standard size overcurrent device to be chosen. Therefore, the maximum size overcurrent device permitted for this situation is 70 A. A smaller size overcurrent device could have been used; for example, 60 A. In fact, the overcurrent device can be as small as desired as long as it is large enough to satisfy the load requirements.

If the primary full-load current is less than 9 A, the primary overcurrent device is not permitted to exceed 1.67 (167%) times the primary full-load current, *NEC Section 450-3(b)(1), Exception No. 1*. If the primary current is less than 2 A, the overcurrent device is not permitted to exceed 3.0 (300%) times the primary full-load current, *NEC Section 450-3(b)(1)*.

Consider the case of a 3-kVA transformer stepping down 480 V to 120 V to supply one 20-A single-phase circuit. The primary full-load current is 6.25 A.

$\text{Primary current} = \frac{3 \text{ kVA} \times 1\,000}{480 \text{ V}} = 6.25 \text{ A}$
---

The overcurrent device is sized at 125% of the primary full-load current.

$\text{Overcurrent size} = 6.25 \text{ A} \times 1.25 = 7.8 \text{ A}$
--

The next standard size overcurrent device larger than 7.8 A may be used as long as it does not exceed 167% of the primary current.

$6.25 \text{ A} \times 1.67 = 10.4 \text{ A}$
---

A 10-A time-delay fuse is the maximum size permitted to protect the 3-kVA transformer. Time-delay fuses are used when the overcurrent device is sized at less than 15 A.

The overcurrent device protecting the primary of a transformer is permitted to be sized as large as 2.50 (250%) times the primary full-load current, provided the transformer secondary is also protected, Figure 14-25. The transformer secondary overcurrent device is sized a 1.25 (125%) times the secondary full-load current. The next size larger overcurrent device is permitted except where the secondary current is less than 9 A. In this case, the overcurrent device is not permitted to be larger than 1.67 (167%) times the transformer secondary circuit.

Consider again the 3-kVA, single-phase, 480-V-tc

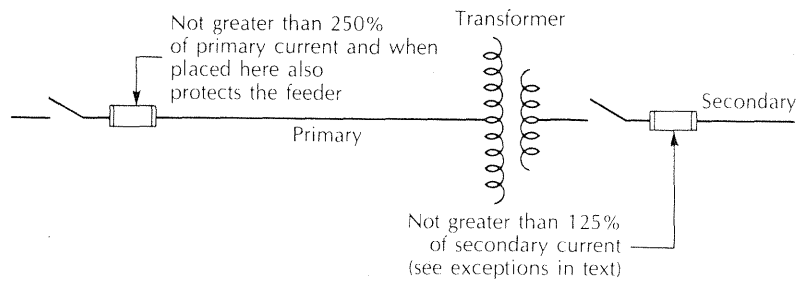

**Figure 14-25** If the transformer is protected on the secondary with an overcurrent device rated at not more than 125% of the secondary current, the primary overcurrent device may be sized as large as 250% of the primary current.

120-V step-down transformer of the previous example. Assume that the input wire is No. 14 AWG copper with THW insulation, and that it is protected by a 15-A circuit breaker. The circuit breaker clearly is too large to serve as the sole protection for the transformer. But, the 15-A circuit breaker is less than 250% of the transformer full-load current.

$$6.25 \text{ A} \times 2.50 = 15.6 \text{ A}$$

An overcurrent device installed to protect the transformer secondary at 125% of the secondary full-load current will satisfy the Code requirements for transformer protection, *NEC Section 450-3(b)(2)*.

Secondary full-load current	=	$\frac{3 \text{ kVA} \times 1000}{120 \text{ V}}$
		= 25 A
Secondary overcurrent device	=	$25 \text{ A} \times 1.25$
		= 31 A

A 30-A fuse or circuit breaker at the transformer secondary will provide adequate transformer protection. Recall that the purpose of installing the transformer was to provide one 20-A circuit. It would then make sense to provide a 20-A fuse or circuit breaker at the transformer secondary, Figure 14-26.

Some transformers may have a thermal protector installed by the manufacturer to sense transformer overload and open the input circuit. The transformer nameplate will indicate if it is thermally protected. A thermally protected transformer requires secondary overcurrent protection sized at 1.25 (125%) times the secondary full-load current, the same as in the previous example.

The thermally protected transformer, with an impedance of 6% or less, is permitted to have the primary protected at not greater than six times the primary full-load current. If the transformer impedance is more than 6% but less than 10%, the primary protection must not exceed four times the primary full-load current, Figure 14-27.

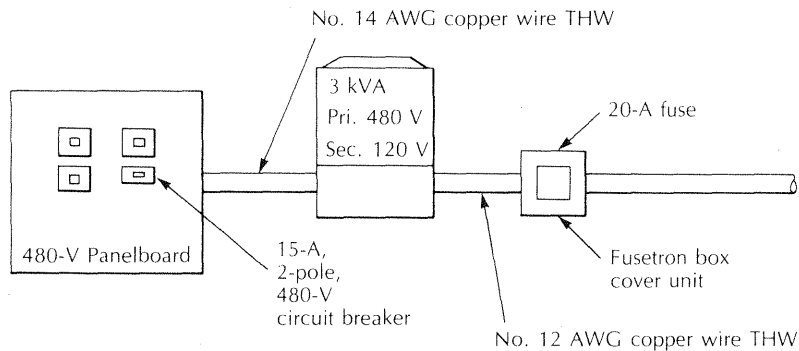

**Figure 14-26** Transformer supplying one circuit is protected on both the primary and secondary



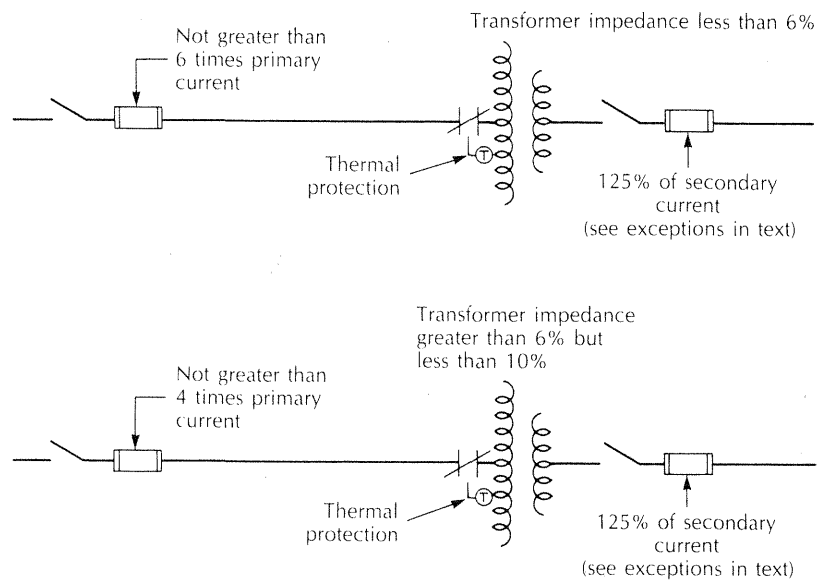

Figure 14-27 Overcurrent protection for a transformer with factory-installed thermal protection on the primary

## WIRE SIZE AND PROTECTION

Electrical wires must be adequate to supply the load and protected from overcurrent, according to the wire ampere rating as given in *NEC Table 310-16*. Therefore, wire ampere rating must also be considered when sizing transformer overcurrent devices. An example will help to illustrate the procedure of sizing feeder wires and overcurrent protection.

A 100-A, 120/208-V, 3-phase panelboard is supplied from a 480-V, 3-phase system through a 37.5-kVA step-down transformer, Figure 14-28.

The first procedure is to determine the primary and the secondary full-load currents.

Primary full-load current	
	$= \frac{37.5 \text{ kVA} \times 1\,000}{1.73 \times 480 \text{ V}} = 45 \text{ A}$
Secondary full-load current	
	$= \frac{37.5 \text{ kVA} \times 1\,000}{1.73 \times 208 \text{ V}} = 104 \text{ A}$

The 120/208-V panelboard in the example is rated at 100 A; therefore, it must be protected at not more than 100 A, *NEC Section 384-16(a)*. An overcurrent device must be provided on the secondary side of the transformer because the transformer is 3 phase and the feeder consists of more than two wires, *NEC Sections 384-*

*16(d)* and *240-3, Exception No. 5*. A fusible disconnect switch is installed adjacent to the transformer. If 100-A fuses are installed in the disconnect switch, a main breaker will not be needed in the 100-A panelboard. The secondary feeder wire must have an ampere rating of at least 100 A. No. 3 AWG copper with THWN insulation is adequate.

The primary overcurrent device is not permitted to exceed 250% of the primary full-load current.

$$45 \text{ A} \times 2.5 = 112 \text{ A}$$

But, there is no reason to protect the primary at 100 A which is the largest size fuse that does not exceed 112 A. If the fuses are sized at 110 A, then the wire must be rated for 110 A. In this example, find a copper THWN wire from *NEC Table 310-16* which is rated for at least 45 A. No. 8 AWG copper THWN wire is rated at 50 A. Therefore, install 50-A fuses in the 480-V panelboard.

The disconnect switch in Figure 14-28 must be located so that the wire from the transformer is not more than 25 ft (7.62 m) in length, *NEC Section 240-21, Exception No. 8*. This tap conductor must have an ampere rating sufficient to supply the load; in this case, at least 100 A. It must end at a circuit breaker or set of fuses with a rating not greater than the ampere rating of the tap conductor. The tap conductor must be enclosed in race way.



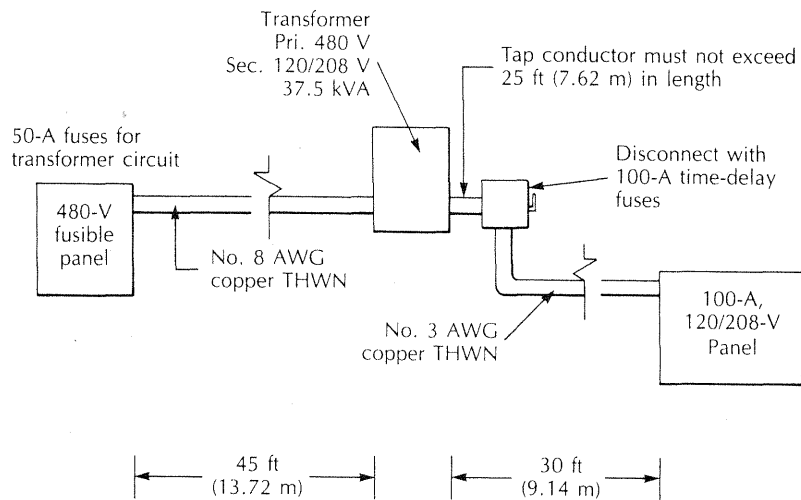

Figure 14-28 A 3-phase transformer supplying a 120/208-V, 100-A panelboard

If the 100-A panelboard of Figure 14-28 is within 25 ft (7.62 m) of the transformer, the disconnect switch can be eliminated, and a set of 100-A main fuses or a 100-A main circuit breaker can be installed in the panelboard, as shown in Figure 14-29. The minimum size secondary wire would be No. 3 AWG copper THWN.

A 2-wire secondary from a single-phase transformer is permitted to be protected by the transformer primary overcurrent device, *NEC Section 240-3, Exception No. 5*. However, there is a *caution*. The primary overcurrent device must be sized so that the secondary wire cannot become overloaded. Equation 14.9 can be used to determine the maximum size primary overcurrent device rating.

Maximum primary fuse rating	<b>Eq. 14.9</b>
= $\frac{\text{Secondary voltage}}{\text{Primary voltage}} \times \text{Secondary wire ampacity}$	

An example will help to illustrate how a primary fuse can protect the secondary circuit wire. Consider a 2-kVA, 480-V-to-120-V, single-phase step-down transformer supplying one circuit for lights and receptacle outlets.

First, determine the primary and the secondary full-load current for the 2-kVA transformer.

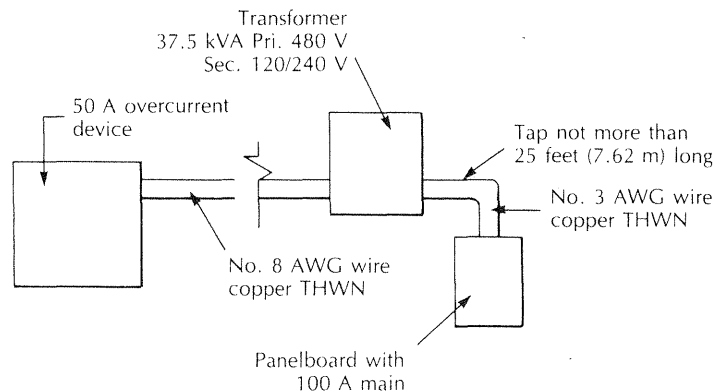

Figure 14-29 The panelboard is kept within 25 ft (7.62 m) of the transformer and the fusible disconnect is eliminated. A 100-A main breaker is installed in the panelboard.

Primary full-load current	$= \frac{2 \text{ kVA} \times 1\,000}{480 \text{ V}} = 4.2 \text{ A}$
Secondary full-load current	$= \frac{2 \text{ kVA} \times 1\,000}{120 \text{ V}} = 16.7 \text{ A}$

If the secondary wire is No. 14 AWG copper, it has a maximum load ampere rating of 15 A. Equation 14.9 is used to determine the maximum size primary fuse permitted.

Maximum primary fuse rating	$= \frac{120 \text{ V}}{480 \text{ V}} \times 15 \text{ A} = 3.75 \text{ A}$
-----------------------------	--

If the secondary wire is No. 12 AWG copper, then it has a maximum load ampere rating of 20 A.

Maximum primary fuse rating	$= \frac{120 \text{ V}}{480 \text{ V}} \times 20 \text{ A} = 5 \text{ A}$
-----------------------------	---

But, if the primary fuse is sized at 5 A, the transformer could become overloaded. The best choice would be to size the primary fuse at 4 A, and install a No. 12 AWG secondary wire. The maximum secondary current will be 16 A, which is slightly below the secondary full-load current. This transformer circuit is shown in Figure 14-30.

Sizing transformer circuit conductors and overcurrent protection requires careful thought and good judgment.

## MOUNTING TRANSFORMERS

Transformers must be installed in an area that will minimize the possibility of physical damage, *NEC Section*

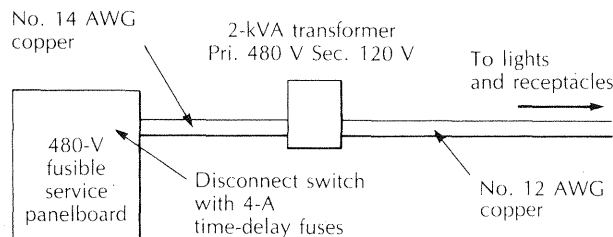

**Figure 14-30** The primary fuse is sized to protect the transformer and the secondary wire.

*Section 450-8(a)*. It must be remembered that transformers are not 100% efficient and, therefore, they produce heat. They must be installed in an area where there is free circulation of air around the transformer, *NEC Section 450-9*. Dry-type transformers rated at 600 V and less, and not more than 112.5 kVA, should be mounted on fire-retardant material. Transformers rated at more than 112.5 kVA shall be installed in a transformer room of fire-retardant construction, *NEC Section 450-21*. Transformers mounted outdoors shall have a waterproof enclosure and, if rated at more than 112.5 kVA, shall be spaced at least 12 in (305 mm) from combustible materials of buildings.

## GROUNDING

The alternating-current system derived from the transformer is required to be grounded the same as the building electrical service entrance, *NEC Section 250-26*. *NEC Section 250-5* specifies the wire which must be grounded. The grounded wire, usually the neutral, must be connected to a grounding electrode. This grounding connection can be made at the transformer, or at a service panel or disconnect switch supplied from the transformer, Figure 14-31.

The grounding electrode shall be as close as possible to the point where the grounding electrode conductor connects to the grounded circuit wire. Acceptable grounding electrodes listed in *NEC Section 250-26(c)* are:

- The nearest available effectively grounded structural metal member of the structure
- The nearest available effectively grounded metal water pipe

If neither of these grounding electrodes is available, then one of the grounding electrodes described in *NEC Sections 250-81* and *250-83* shall be used.

The size of the grounding electrode conductor is based upon the size of the output conductor from the transformer, using *NEC Table 250-94*.

A bonding jumper is required between the grounding electrode conductor of the derived system and the metal enclosure of the transformer, *NEC Section 250-26(a)*. This connection is permitted to be made at a panelboard or disconnect supplied by the transformer.

The transformer is required to be grounded and bonded at the transformer when the secondary has no disconnect or overcurrent protection, but is protected only by the primary overcurrent device.

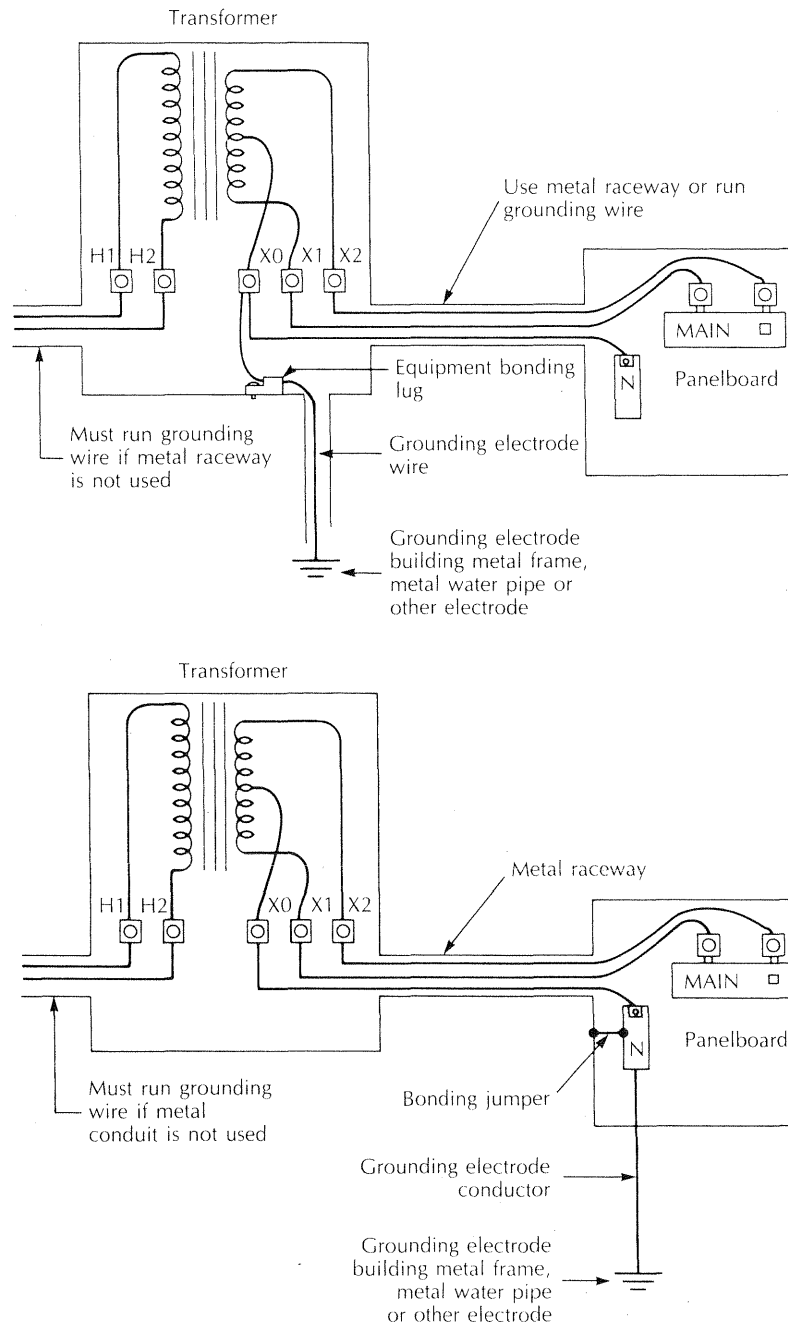

Figure 14-31 Methods of grounding and bonding a separately derived system from a transformer

## CONTROL TRANSFORMERS

Transformers used only for the purpose of supplying power to control motors and equipment come under the category of a Class 1 circuit, *NEC Section 725-11*. The

installation of these transformers is covered by *NEC Article 450*, as discussed in this unit. Control transformers are available with a fuseholder on the primary side to provide transformer protection, as required in *NEC Sections 725-11, 725-12, and 430-72*.

A grounding electrode and grounding electrode conductor are not required for these transformers as long as the transformer is rated at not more than 1 000 VA

(1 kVA), *Exceptions to NEC Section 250-26*. Grounding can be accomplished by bonding the wire to be grounded to the metal frame of the transformer or enclosure.

## REVIEW

Refer to the *National Electrical Code* when necessary to complete the following review material. Write your answers on a separate sheet of paper.

1. Explain the purpose of a transformer.
2. As electrical current flows through a wire, is a force field built up around the wire?
3. Describe what will happen if a magnetic field is moved across a wire.
4. A transformer operates on the principal of what kind of induction?
5. A transformer has a primary to secondary turns ratio of 15 to 1. If the primary is rated at 240 V, then the secondary voltage is:
  - a. 120 V
  - b. 24 V
  - c. 16 V
  - d. 12 V
6. A transformer has a primary rated at 240 V and a secondary rated at 120 V. The primary to secondary turns ratio is:
  - a. 4
  - b. 2
  - c. 0.5
  - d. 0.25
7. The primary full-load current of a 3-phase, 480-V-to-120/208-V step-down transformer with a 30-kVA rating is:
  - a. 36 A
  - b. 45 A
  - c. 62 A
  - d. 83 A
8. A control transformer has a secondary rated 10.4 A at 24 V. The primary is rated 480 V, and the primary to secondary turns ratio is 20 to 1. Of the following, which is the primary full-load current?
  - a. 2.08 A
  - b. 1.22 A
  - c. 0.80 A
  - d. 0.52 A
9. Of the following diagrams A, B, C, and D, which represents an autotransformer?

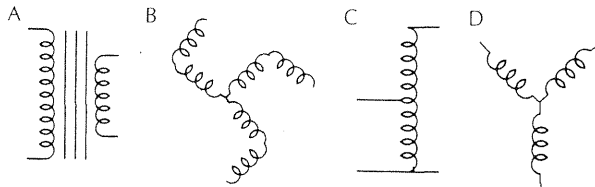

10. Of the diagrams A, B, C, and D for Problem No. 9, which represents an insulating transformer?
11. In the following diagram, show in pencil how to connect the 120/240-V primary and the 12/24-V secondary to obtain a 24-V output when the input to the transformer is 240 V.

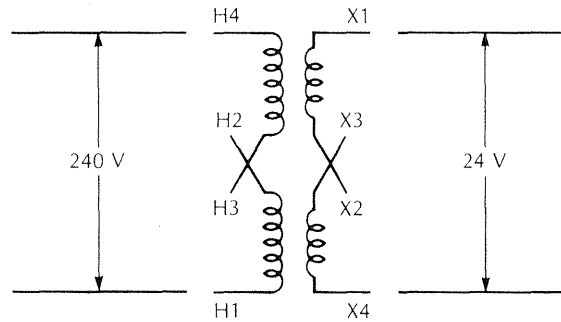

12. The 3-phase transformer in the following diagram is connected:
- Wye-wye
  - Wye-delta
  - Delta-wye
  - Delta-delta

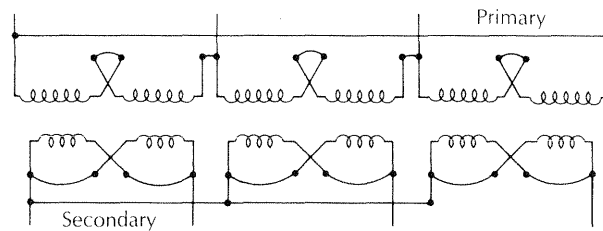

13. A single-phase step-down transformer is wired for a 120/240-V, 3-wire output. If the input voltage is only 440 V, show how to connect the primary so that the output will be close to but will not exceed 240 V.

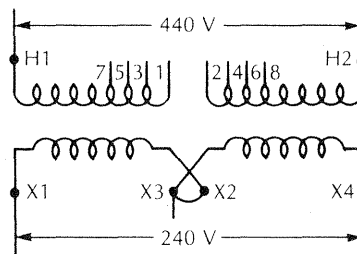

14. What is the name of the insulating transformer that can be connected as an autotransformer to raise 208 V up to 230 V?
15. A building is supplied with a 480-V, 3-phase electrical system. The kVA rating of a single-phase transformer required to supply a 60-A, 3-wire, 120/240-V panelboard is:
- 10 kVA
  - 15 kVA
  - 20 kVA
  - 37.5 kVA

16. A 6-kVA, 3-phase transformer is used to step up 240 V to 480 V to supply a machine with a 3-phase motor. The secondary of the transformer is protected with 8-A time-delay fuses. What is the maximum size circuit breaker permitted to be installed to protect the primary side of the transformer?
- 15 A
  - 20 A
  - 30 A
  - 40 A

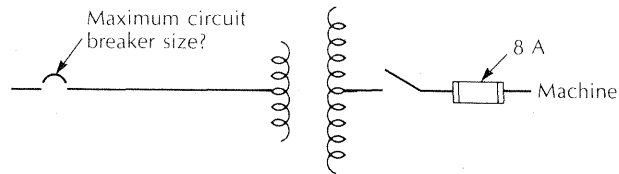

17. A 2-kVA, single-phase transformer is used to supply one 120-V circuit for lights and receptacles. The building is served with 240 V, 3 phase. The secondary circuit is protected by 8-A fuses on the primary side of the transformer. The minimum size secondary copper TW wire is No. \_\_\_\_\_ AWG.
- 10
  - 12
  - 14
  - 16

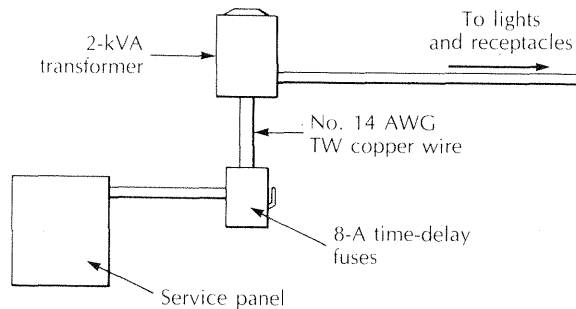

18. The buck and boost transformer has a primary rated at 120/240 V, and a secondary rated at 12/24 V. (See the diagram at the top of page 295.) Of the following, which is the output voltage of the transformer?
- 71 V
  - 107 V
  - 114 V
  - 119 V

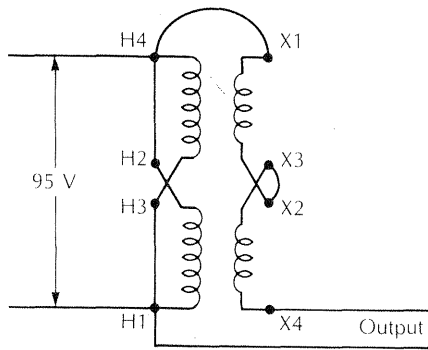

19. On a separate sheet of paper, make a sketch of the transformer shown below, and draw in the grounding and bonding wires required for this single-phase, 480-V primary, 120/240-V secondary, 37.5-kVA transformer.

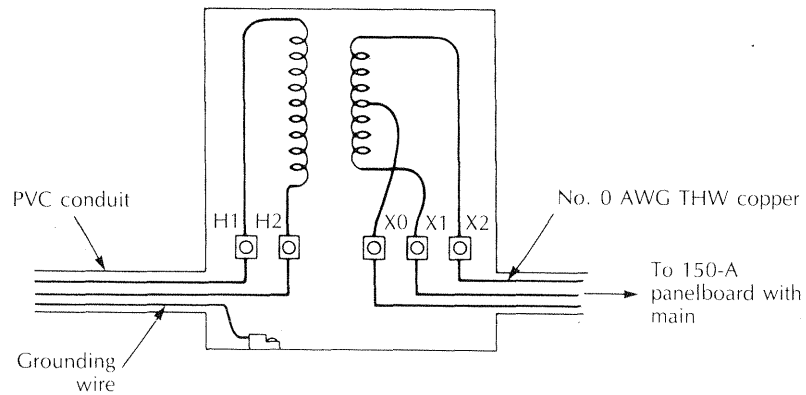

20. The minimum size copper grounding electrode conductor and equipment bonding jumper for the transformer in Problem No. 19 is:
- 0
  - 2
  - 4
  - 6

13. A typical heating cable mat for outside ice and snow melting has a watts-per-square-foot rating of:
  - a. 10
  - b. 20
  - c. 30
  - d. 40
14. What is the minimum concrete finish-coat thickness when poured over electric cable?
15. The lead wires for a 240-V electric heating cable are color coded:
  - a. Yellow
  - b. Brown
  - c. Red
  - d. Blue
16. List three sources of heat on a farm from other than a space heater.
17. A herd of dairy cows produces 1 500 pounds of milk every time the herd is milked. The amount of heat removed from the milk by the milk tank cooling system is:
  - a. 30 000 Btu
  - b. 40 000 Btu
  - c. 70 000 Btu
  - d. 90 000 Btu
18. A refrigeration unit nameplate is rated at 230 V, single phase, and has a full-load current rating of 16 A. The locked-rotor current is 65 A. The minimum rating of the disconnect switch is required to be:
  - a. 3 hp
  - b. 5 hp
  - c. 7.5 hp
  - d. 10 hp
19. A 120-V room air conditioner draws 9.5 A. Is it permissible to plug this unit into an existing general-purpose 20-A circuit? Which *NEC* section supports your answer?
20. Describe a heat pump.