

**Three Phase Transformer Winding Configurations and
Differential Relay Compensation**

Larry Lawhead, Randy Hamilton, John Horak
Basler Electric Company

Presented before the
60th Annual Georgia Tech
Protective Relay Conference
May 2-5, 2006

This page intentionally left blank.

Three Phase Transformer Winding Configurations and Differential Relay Compensation

Larry Lawhead, Randy Hamilton, John Horak
Basler Electric Company

Most engineers have some familiarity with two commonly known delta connections that give either a $+30^\circ$ or -30° phase shift of positive sequence voltages and currents, and just these two configurations seem to cause extensive confusion. There are actually many other ways to configure a wye or delta that give other phase shifts, and to further complicate matters, there is the occasional zigzag winding application and the additional confusion over what occurs when CTs are connected in delta. These alternate transformer winding configurations are sometimes referred to by terms such as Dy# or Yy#, or Yd#, Dz#, and Yz#, and where the # can be, seemingly, almost any hour of the clock, hence the term “around the clock” phase shifting is sometimes heard. The paper will review the variety of possible winding configuration and give examples of the nomenclature that is used with them and how these various phase shifts are created.

The paper will also show how a transformer differential relay compensates for the effects of the various transformer winding configurations, as well as account for delta CT configurations. Many papers and instruction manuals refer to compensation in terms of phase shifting. This leads engineers to have a vague and misleading understanding that the relay is somehow phase shifting currents to compensate for the transformer phase shift. While a “sequence component differential” relay might be able to work this way, most transformer differential relays work outside of the sequence component domain and do some form of current balance calculation in the ABC domain.

Basic Transformer Design Concepts

Before proceeding, let us review a few points on transformer design and review some nomenclature that will be used in the paper.

Since this paper is aimed at describing transformers that use phase shifts and winding designs that are more commonly found outside the US market, the phase and bushing names of **U**, **V**, **W**, will be used generally, rather than **A**, **B**, and **C**, or **H** and **X**. The means of specifying phase shift and transformer connection will be the D-Y-Z + clock method. For instance, a transformer connection will be Dy1 rather than a D_{AB}/Y , though some dual designations will be used for clarity.

If one browses transformer sales literature, technical papers and books, and industry standards such as IEEE C57.12.00 and IEC-60076-1, one will find many variations on the nomenclature and figures used to show how the phases are identified in a three phase system. Figure 1 is a composite of some of the identification methods that will be found. Besides the terms seen in Figure 1, the terms **R**, **S**, and **T** are used in some sources to name the phases. Also, various color schemes are used. Some use of the colors black, red, and blue, or brown, orange, and

Prepared by Basler Electric for presentation to the
Georgia Tech Protective Relay Conference, May 2006
2/14/06. Comments: info@basler.com

yellow to reference the phases. White is sometimes used rather than blue, but white is also commonly used for neutral in low voltage applications too. Green or bare copper is generally used for a ground conductor.

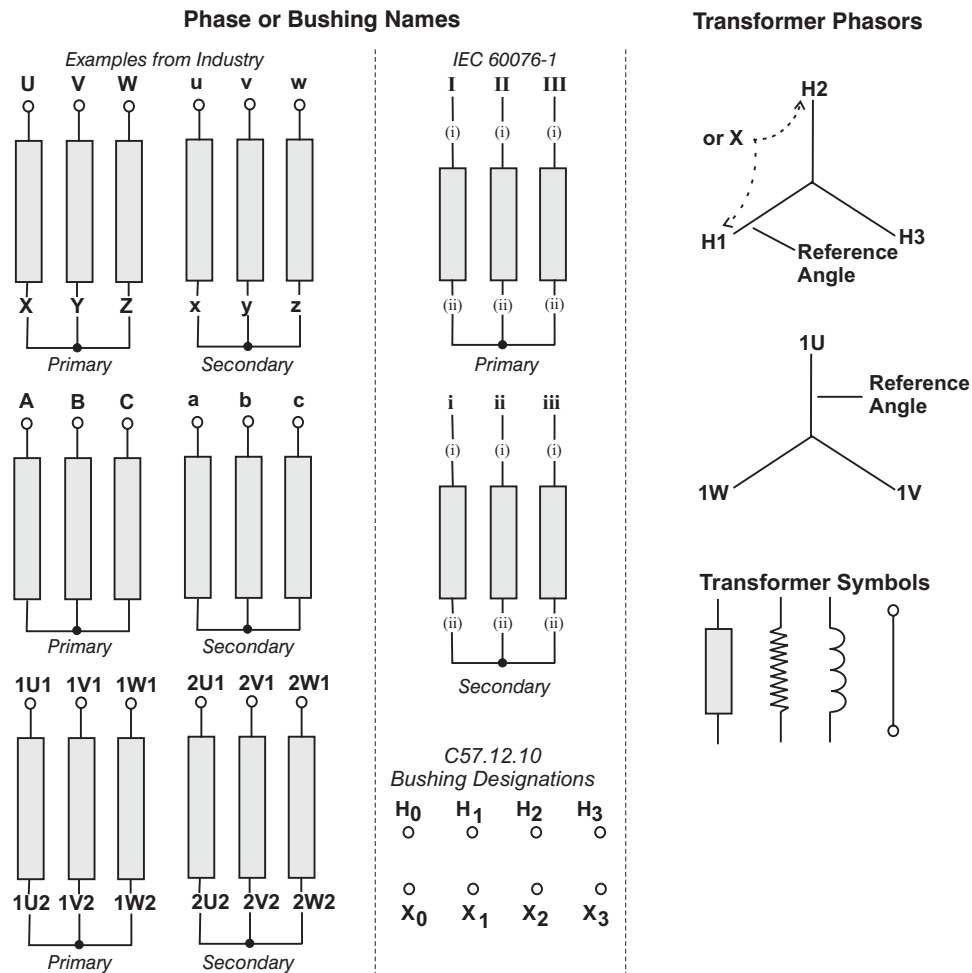

Figure 1 - Example Transformer Symbology and Terminations

Many times the figures that are used to model a transformer and show its connections do not clearly indicate which windings share a common core leg, and do not clearly indicate the polarity of the coupled windings, at least to the first time reviewer. To make the winding polarity more evident in this paper, a variation of the drawings above will be presented that makes it clearer where the polarity of the windings is and which windings share a common transformer leg. See Figure 2.

We need to define the term “Winding” to avoid confusion. In various sources the term winding can refer to either a single continuous coil of wire on a single core leg, or collectively to a 3 phase set of windings connected to the **1U**, **1V**, and **1W** bushings, or even the group of windings associated with a particular phase. Herein, a “winding” is a single continuous coil of wire on a single core leg, a “winding set” is the set of three windings that constitute the three phases, each on different core legs, with a common terminal voltage level (e.g., **1U**, **1V**, and **1W**), and a “phase set” will refer to the two or more windings that are found on a common core leg. See Figure 2.

The windings in the transformer figures are given the terms W_{1-9} . The winding sets associated with the various voltage levels, each on a different core leg, are:

Winding Set 1: W_1 , W_2 , and W_3

Winding Set 2: W_4 , W_5 , and W_6

Winding Set 3: W_7 , W_8 , and W_9 (only seen herein in zigzag transformers).

The windings sharing a common core leg are:

Core Leg 1: W_1 and W_4

Core Leg 2: W_2 and W_5

Core Leg 3: W_3 and W_6

(Windings W_7 , W_8 and W_9 , used herein for zigzag windings, are hard to classify into a particular leg since zigzag windings cross-connect core phase legs.)

(In the figures, core leg 1 is abbreviated as ΦA , core leg 2 as ΦB , and core leg as ΦC .)

The windings by themselves are passive devices and which winding is given the number W_1 , W_2 , or W_3 (or W_4 , W_5 , W_6 , W_7 , W_8 , or W_9) will not matter initially, but it will matter when we connect the second set of windings to the various bushings since this will affect phase shift of positive (and negative) sequence voltages across the transformer.

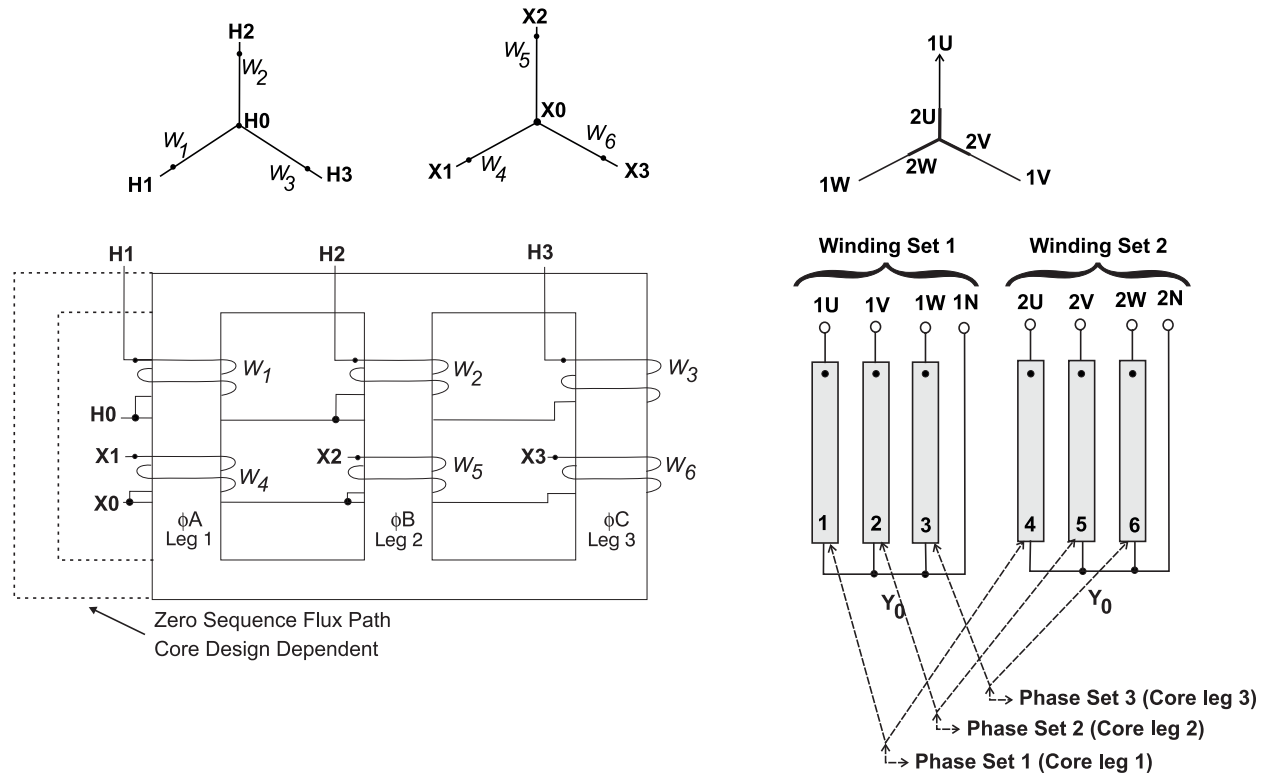

Figure 2 - Basic Transformer Representation

The paper will show the balanced transformer output current in terms of the flux in the core that is due to load current, which invites discussion on how load flux distributes in a core. There are two issues with core design that affect differential relaying.

First, we normally think in terms of power flow in a transformer as staying within a phase set (i.e., current in a single phase on the secondary of a three phase transformer will generate current in the primary only of that same transformer leg), but this is not always the case.

Normally when current flows in the secondary winding, it generates a flux in that leg and an equal but opposing flux is generated by load current flowing in the primary on that same phase leg so that the level of excitation flux remains constant. However, in a three phase transformer where all phases are magnetically linked, there is some coupling and power transfer between the phases, especially in the 3 legged core design. The inter-phase coupling provides a mechanism where an external fault on one phase can cause current on unfaulted phases and is part of the limitation on sensitivity of a transformer differential relay.

The highest inter-phase coupling occurs in a three legged core transformer. Note that in a 3 legged core all flux that leaves a leg must pass through another leg or air. Examine Figure 2. Assume some current flows in the W_4 winding. This current will tend to create flux in a direction that demagnetizes the W_4 core, resulting in lower back e.m.f. on the W_1 primary. Since in this core the flux in the Φ_A leg divides between the Φ_B and Φ_C legs, the W_2 and W_3 windings could supply the current/flux to counter the W_4 load. However, W_4 is generally wired directly under or interleaved within W_1 , so the W_1/W_4 coupling is stronger than W_2/W_4 or W_3/W_4 coupling. Also, it can be shown that the source that will supply the load current with the least reactive current flow is W_1 . Hence virtually all the current required to counter the W_4 load flux will come from W_1 . If current did come from W_2 or W_3 the transformer differential relay would tend toward tripping.

In the 4 legged and core form designs, there are flux paths that allow flux to flow without entering other phases, so each phase is more independent of what is occurring in the other phases and is indicated in Figure 2 as the zero sequence flux path. In the 5 legged / 4 core designs, where each phase winding encircles two cores, used mostly on low cost distribution transformers, the two outside phases are fairly independent of each other, but the inside phase can be affected by events in either of the two outside phases.

Directly related, a significant difference between core designs that can affect differential protection is whether the core can support zero sequence voltage. If there is no independent zero sequence flux path, as in the three legged core design, and zero sequence voltage is applied to the windings, the excitation flux is forced to travel through air to complete the flux circuit. Excitation current will be very high and can make a transformer differential operate. This high excitation current is sometimes masked in differential relays by schemes that filter zero sequence current from the differential relay. This can be done by connecting CTs in delta, or in numeric relays, by algorithms that measure zero sequence current entering the windings and subtract it from the differential analysis. The ability to remove the zero sequence current mathematically in modern numeric differential relays has reduced the motivation to connect differential relay CTs in delta in most applications.

While the connection diagrams to follow will generally show a three legged core, this is only for convenience. The connection diagrams are applicable to either 3x1 phase designs or any three phase core. In all designs, the windings for any given phase are still on a common leg of the core.

Positive Sequence Phasing and Even More Possible Winding Configurations

The entire paper assumes positive sequence phase rotation and that all the configuration diagrams were built on positive sequence phase rotation. There are actually more connections than listed if one wishes to do phase rotation changes within the transformer by swapping two phases on only one side of the transformer and leaving the third in place in a way that would convert positive sequence voltage on one side of the transformer to negative sequence voltage on the other side. This seems a fairly remote possibility.

Transformer Winding Configurations

There are 4 basic winding configurations for the typical large 3 phase power transformers: delta, wye, auto, and zigzag. Within the delta, wye, and zigzag groups, there are multiple means of creating the winding configuration. There is some help available in that only a few versions of each show up in regular practice, but this does not rule out any version showing up in one's work (or from a relay manufacturer's point of view, showing up in the relay application) so the possibility should not be excluded from one's plans. Scott T and mid-winding tapped delta transformers are not considered herein.

External vs. Internal Connections

The paper mainly is attempting to analyze the internal connections to the transformer, i.e., what occurs behind the bushings and is unchangeable by the end user. However, the diagrams also can be seen as representations of some forms of external phase connection shifts. For example, in typical practice in the U.S., phases A, B and C connect to bushings H1, H2 and H3 and X1, X2 and X3, respectively. However, in some applications it may be convenient to shift connections and connect A, B and C to H2, H3 and H1 and X2, X3 and X1, respectively.

Wye Winding Configurations

Given three windings, named W_1 , W_2 , and W_3 , and three transformer phase bushings named **U**, **V**, **W**, and a neutral bushing **N**, and assuming a positive sequence rotation is to be maintained, there are 6 different ways the windings and bushings can be interconnected, as shown in Figure 3. Of the 6 variations of wye connections listed, in actual practice almost all connections can be seen in terms of Y_0 or Y_6 . As previously mentioned, which winding is given the number W_1 , W_2 , or W_3 will not matter initially, but we need to keep track of which winding is connected to which bushing so that when we connect the second set of windings we will know the positive sequence phase shift across the transformer.

Phase Shifts Using Clock Notation

Note the use of $Y_{\#}$ for naming each of the configurations. The # refers to the phase angle, as viewed on a 12 hour clock, of winding W_1 relative to the voltage applied to the **U** bushing with a balanced 3 phase positive sequence voltage (**UVW** or **ABC** sequence). Note also the phasor diagrams in Figure 3 that show the phase angle between the W_1 winding and the voltage on the **U** bushing. The relationship between the W_1 voltage and the **U** bushing will become important when one needs a common reference for determining phase shift across the transformer. One finds the phase shift by lining up the W_1 voltages on different sides of a transformer and seeing how the **U** bushing voltages on each side compare.

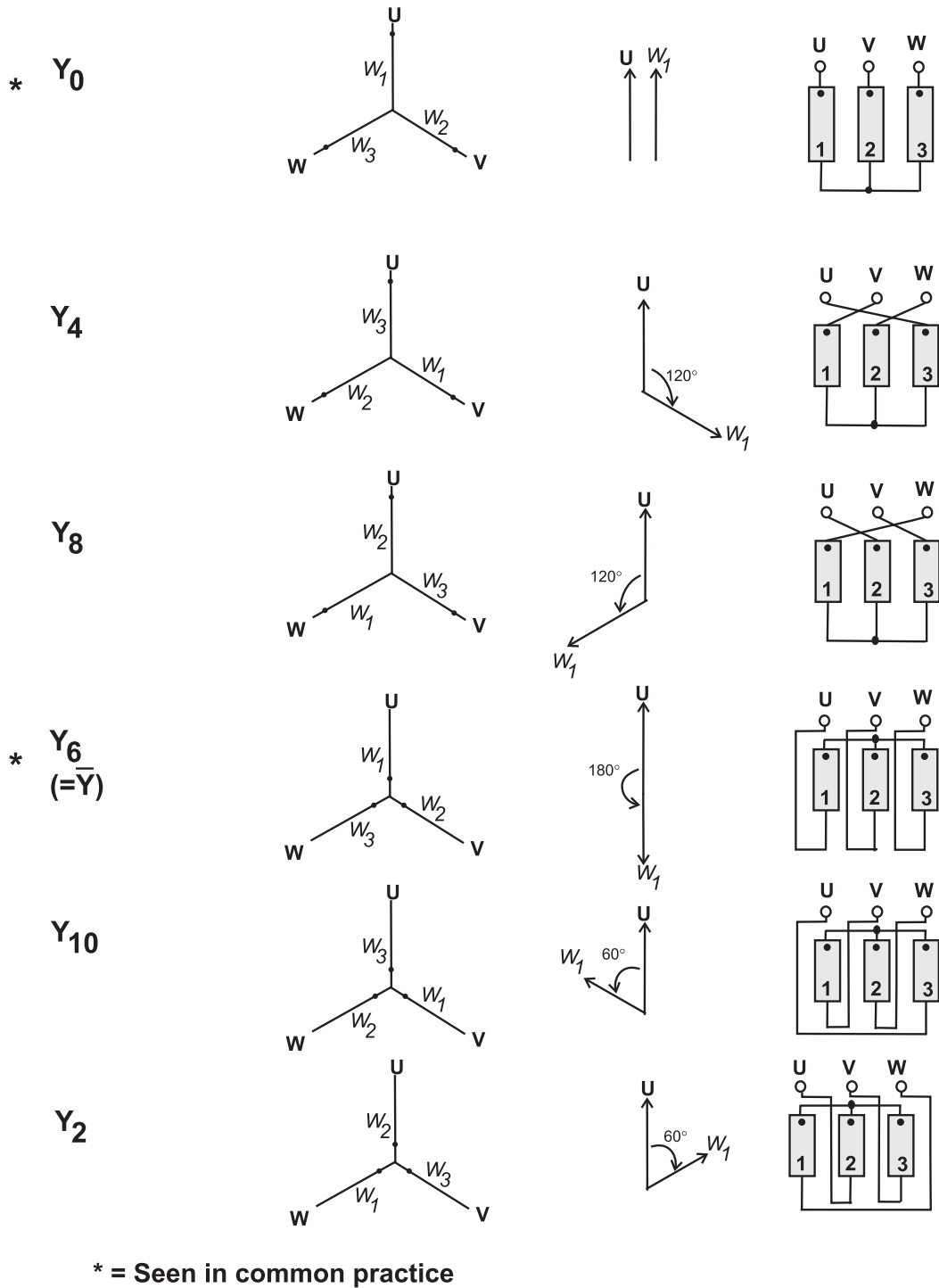
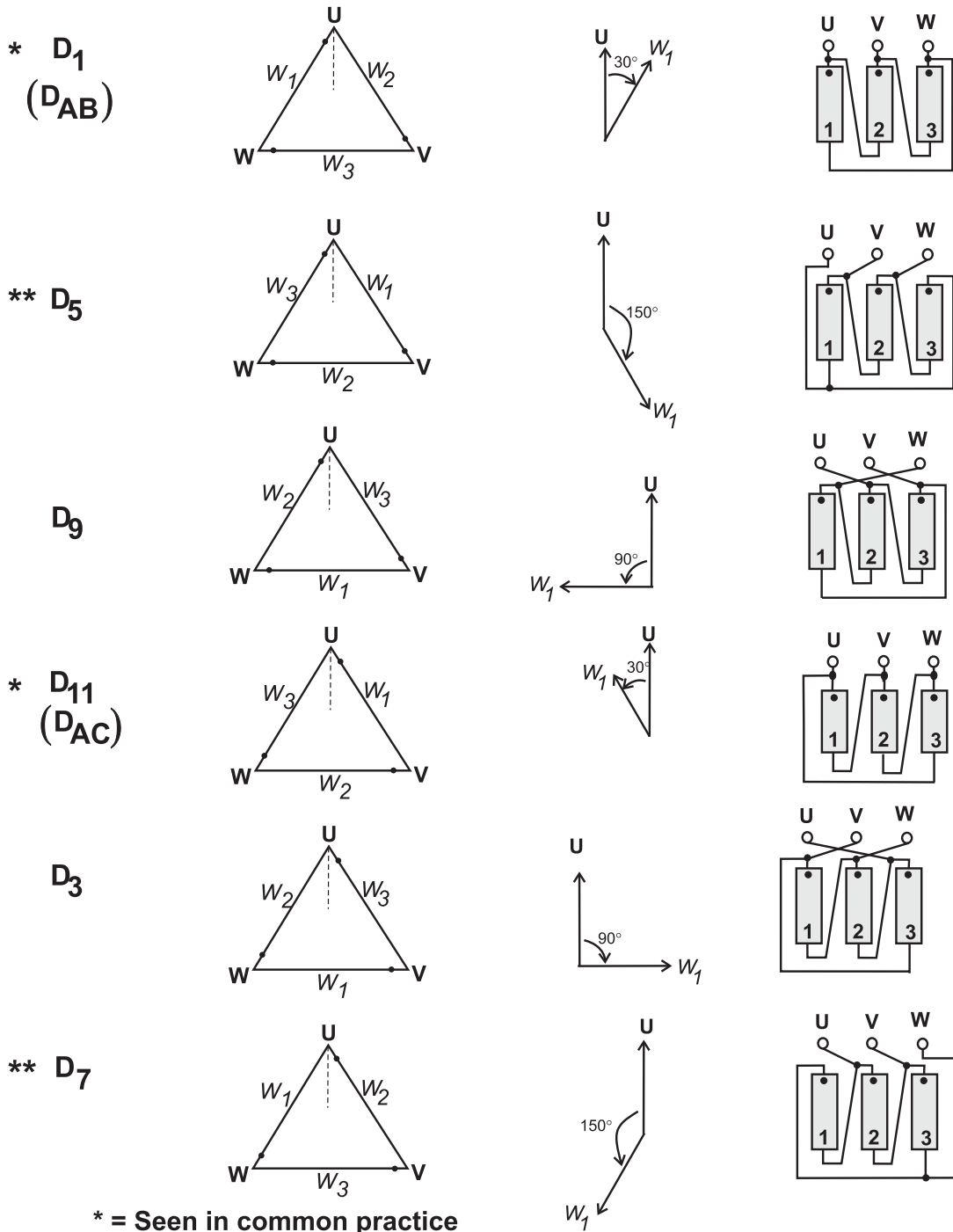

Figure 3 - Six Ways to Wire a Wye Winding

Delta Windings Configurations

Given a set of 3 windings W_1 , W_2 , and W_3 , and three transformer phase bushings **U**, **V**, **W**, and again assuming that positive sequence rotation is to be maintained, there are 6 ways the windings and bushings can be interconnected, as shown in Figure 4. Again, some of the methods would not be seen in normal practice. The most common ones would be D_1 (= D_{AB} in

common US market terminology) and D_{11} (= D_{AC} in common US market terminology). The D_5 and D_7 configurations are seen in some documentation of transformer connections in the international market.



* = Seen in common practice

** = Also seen in reference to worldwide transformer market

Figure 4 - Six Ways to Wire a Delta Winding

Auto-Transformer Winding Configurations

There is no flexibility in how an auto-transformer is wired. The only way to obtain a phase shift is to rename the phases from one side to another, but this is quite uncommon; i.e., given a phase set of W_1 and W_4 , then if **1U** is connected to W_1 then **2U** would almost invariably be connected to the W_4 .

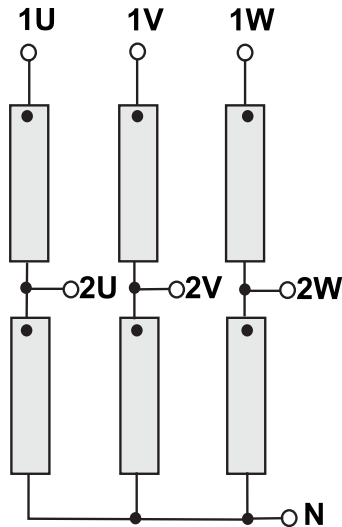

Figure 5 - An Auto Transformer Winding.

The auto-transformer will not be dealt with any further in this paper. The auto-transformer can be treated as a simple wye-wye transformer for current differential calculations. Phase shift in any delta tertiary connection would be treated as a separate delta/wye connection.

Zigzag (Interconnected Star) Winding Configurations

In much literature on transformers, the term “interconnected star” is used in lieu of “zigzag.” However, most engineers in the power engineering business know with at least a little familiarity what is meant by zigzag and this term will be used herein. Zigzag transformers do not see much application in the US. Most engineers are familiar with a zigzag transformer from its application as a ground reference on an ungrounded system. The wye/zigzag transformer is apparently used in some distribution applications due to the lower cost of a high voltage primary wye winding versus a similar voltage delta winding. When the primary is ungrounded wye, the secondary needs to be zigzag in order to remain an effectively grounded secondary. The zigzag winding also is used for obtaining non-standard phase shifts. It is capable of delivering secondary power with 0° , $\pm 30^\circ$ or $\pm 60^\circ$ phase shifts relative to the primary, depending on primary winding configuration.

A zigzag winding is a series connection of two windings whose voltages are 60° out of phase. The two windings are typically the same voltage magnitude, but custom phase shifts can be created if the voltage magnitude of the two windings differs. There are two basic ways to create a zigzag winding:

Connect the U leg in series with V leg (called a Z_{UV} or a Z_{AB}) or

Connect the U leg in series with W leg (called a Z_{UW} or a Z_{AC})

The polarity marks of the two windings either face toward one another or face away from one another. In order to get other phase shifts, some configurations may invert polarity connections,

change which side of the winding the bushings are connected to, or introduce a 120° phase shift by swapping the **U**, **V**, and **W** bushings connections.

The inter-phase coupling that a zigzag winding creates results in primary current patterns that may be quite unlike what one expects with delta and wye primary windings. Unless a delta tertiary is provided, the primary of a three legged core zigzag transformer cannot supply current that will create zero sequence flux in the core. Even if the primary is connected in delta, the winding cannot support ‘circulating I_0 ’ since this creates zero sequence flux. For example: Assume a zigzag secondary and a 1 per unit line to ground fault on the zigzag side. If the primary were wye (see Figure 18), then the current is 1pu on one phase lead, and -1pu on another, similar to a delta/wye bank response. However, if the primary were delta (see Figure 19), the current in the lines feeding the primary will see 2 pu current on one phase and -1 pu on the other two phases, similar to what would be seen for a “double delta” transformation. If power is to flow from the zigzag side to the wye or delta side, a zero sequence flux path or a buried tertiary may be necessary for the transformer to carry any unbalanced loading, even for phase to phase unbalance on a delta primary.

A zigzag winding used as a grounding bank is shown in Figure 6. When a phase **U** line to ground load is applied, the current in the load will want to return via windings W_4 and W_3 . Current in W_4 and W_3 will demagnetize the two respective core legs, which will in turn allow phase to ground voltage on the **W** and **V** to cause current flow in W_1 and W_6 to restore a flux balance condition. The net effect is that equal current flows in every phase of the zigzag bank, which constitutes zero sequence current into the system.

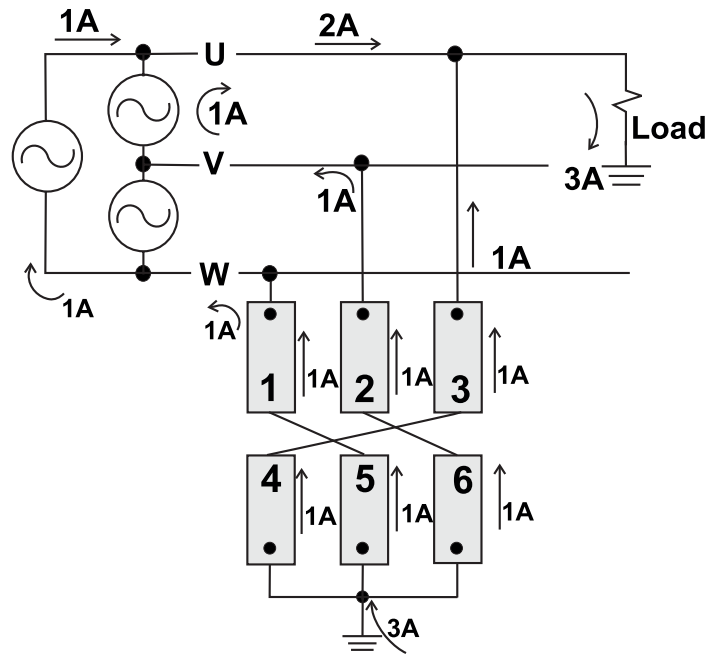
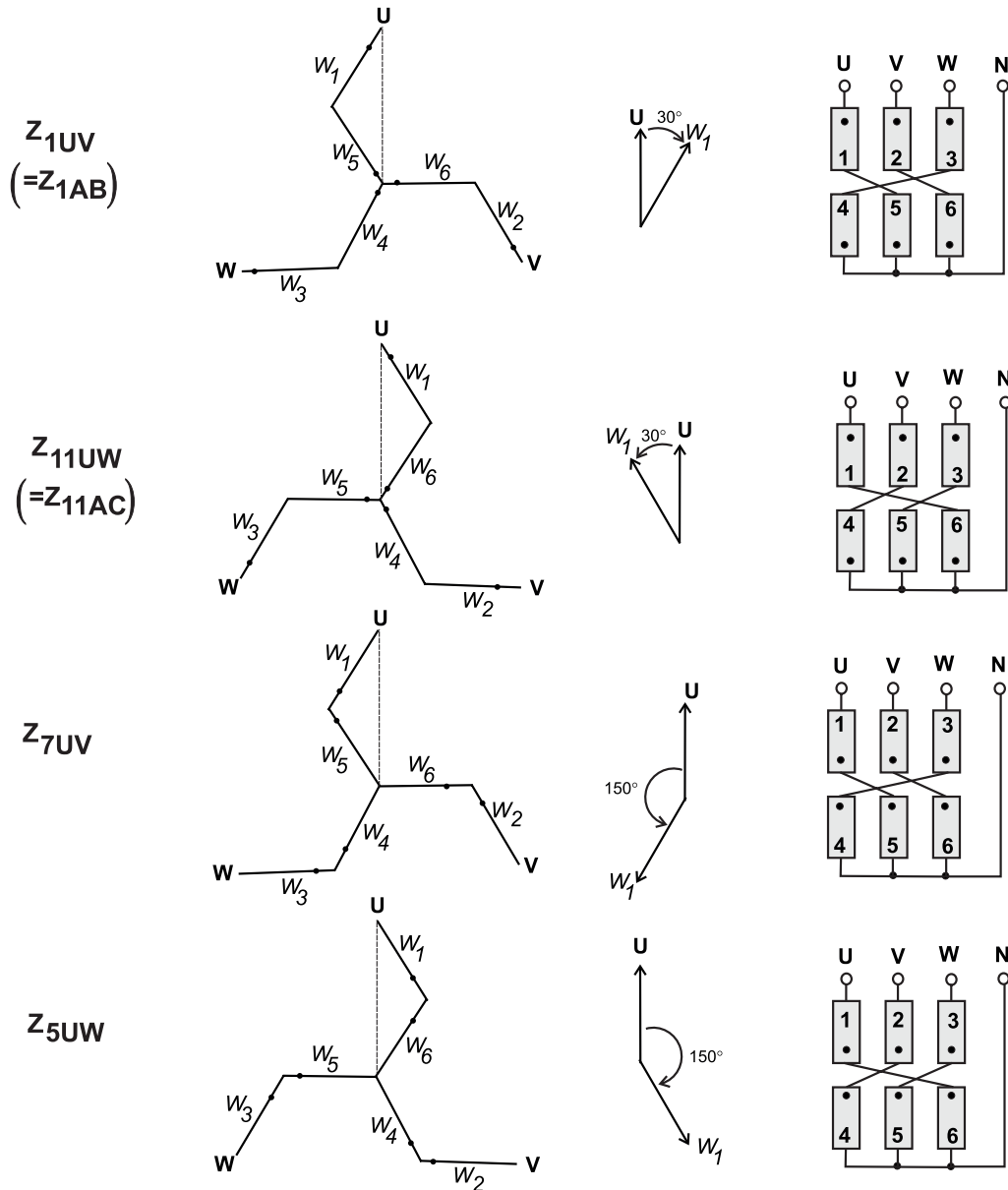

Figure 6 - Zigzag Grounding Bank

Given the 6 windings and three bushings associated with a zigzag winding configuration, there are actually 24 different winding configurations connections that could be made. Again, there are two general types, $Z_{UV} (=Z_{AB})$ and $Z_{UW} (=Z_{AC})$, defined by how the two sets of windings are interconnected and can be seen by inspection of Figure 7. Figure 7 shows what appears to be the more common variations of Z_{UV} and Z_{UW} but note that a 180° inversion of each is possible by

simply inverting the neutral and bushing connection ends, giving 4 more possible variations of Z_{UV} , Z_{UW} or inverted Z_{UV} , or Z_{UW} . See figures for examples. For each R_1 and R_2 swap of the **U**, **V**, and **W** bushing connections one should be able to see 8 more similar variations of the zigzag winding.

To fully define a zigzag connection one needs to specify both the phase shift and whether it is based on Z_{UV} or Z_{UW} . For example, an inspection of Figure 7 will show it is possible to get a Z_1 (30°) phase shift by either the Z_{1UV} connection shown in Figure 7 or by starting with a Z_{5UW} connection and then introducing a 120° phase shift by appropriate **U/V/W** swapping.



Partial listing of possible configurations:

- A 180° reversal of any of these is found by reversing common and HV terminals.
- Phase shifts via swaps of **U**, **V**, **W** not shown.

Figure 7 - Four Ways to Wire a Zigzag Winding

Combining the Various Winding Configurations

An exhaustive listing of all the possible permutations of transformer winding configurations is not worth presenting. Only a small percentage of all the possible winding configurations is commonly found in practice, and many are effectively redundant views of the same configuration. More complete wiring and phasor diagrams of some of the common configurations are given below in figures 8-19 and the rest can be analyzed as needed, using the material as a starting point. Except for the two cases of zigzag windings, only transformers with two basic voltage levels are covered. A somewhat extensive list of the more common configurations is found in [1] IEC60076-1, Power Transformers. Figures 20 and 21 are drawn from this standard without the details of Figures 8-19 but annotated with some additional information.

In the figures to follow, the phasor diagrams found more commonly in US practice are shown on the left, and phasor diagrams that might be more like those found in international practice are shown on the right. Polarity marks have been added to the US practice phasor drawings. The winding diagram in the lower left is intended to show most clearly how the windings would be interconnected, using US practice bushing names. The figure on the lower right shows a common international method of showing the winding connections, except the method has been modified by the addition of polarity marks and winding numbers, and in these figures, when zigzag windings are shown, one winding set is shown with the polarity mark up, and the other with the polarity mark down, so that it is easier to see the interconnection of the windings, compared to IEC drawing practices.

To determine the phase relationship of positive sequence voltage and current between primary and secondary, use the W_1 phasor as the common reference for each winding and compare the resultant angle between the \mathbf{U} phasor on each winding. The angular relationship will be the primary angle minus the secondary angle, on a 12 hour clock. The naming convention given to each of the windings also can be used to determine the phase shift during normal conditions. Consider these examples:

Dy11: $D_{11(UW)}$ pri., Y_0 sec.

Phase shift: $+11-0 = +11$, or -1 . The sec. lags the pri. by 330° or leads the pri. by 30°

Dz_{UV}2: $D_{1(UV)}$ pri., $Z_{11(UW)}$ sec.

Phase shift: $+1-11 = -10$, or $+2$. The sec. lags the pri. by 60° or leads the pri. by 60°

Dy7: $D_{1(UV)}$ pri., Y_6 sec.

Phase shift: $+1-6 = -5$, or $+7$. The sec. lags the pri. by 210° or leads the pri. by 150°

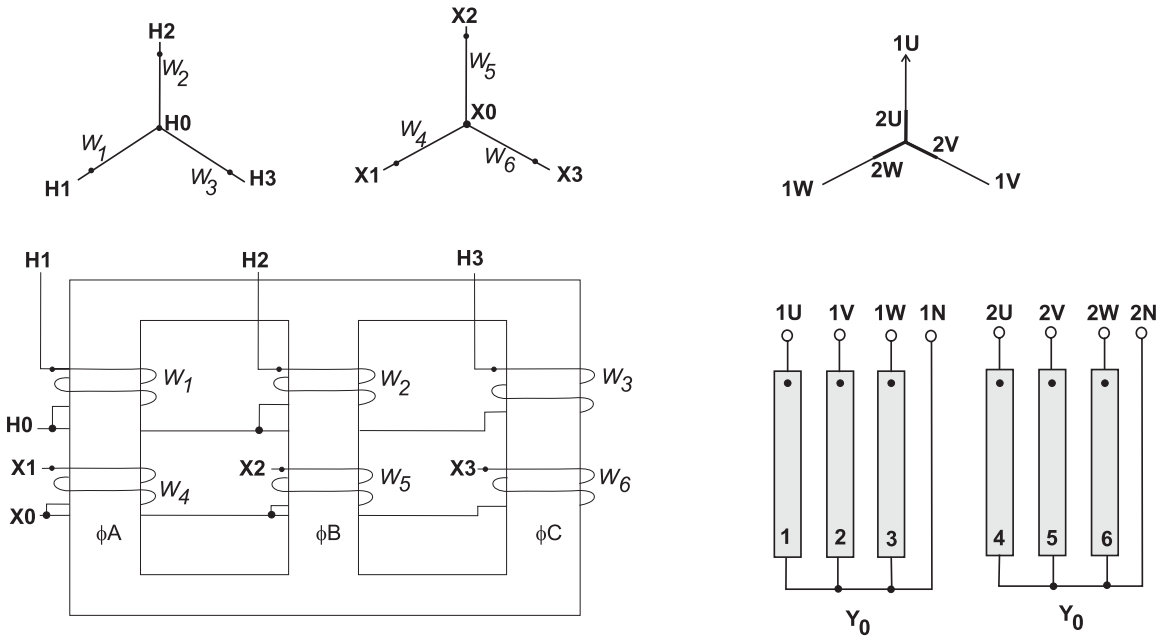

Figure 8 - Yy0 ($Y_0 - Y_0$)

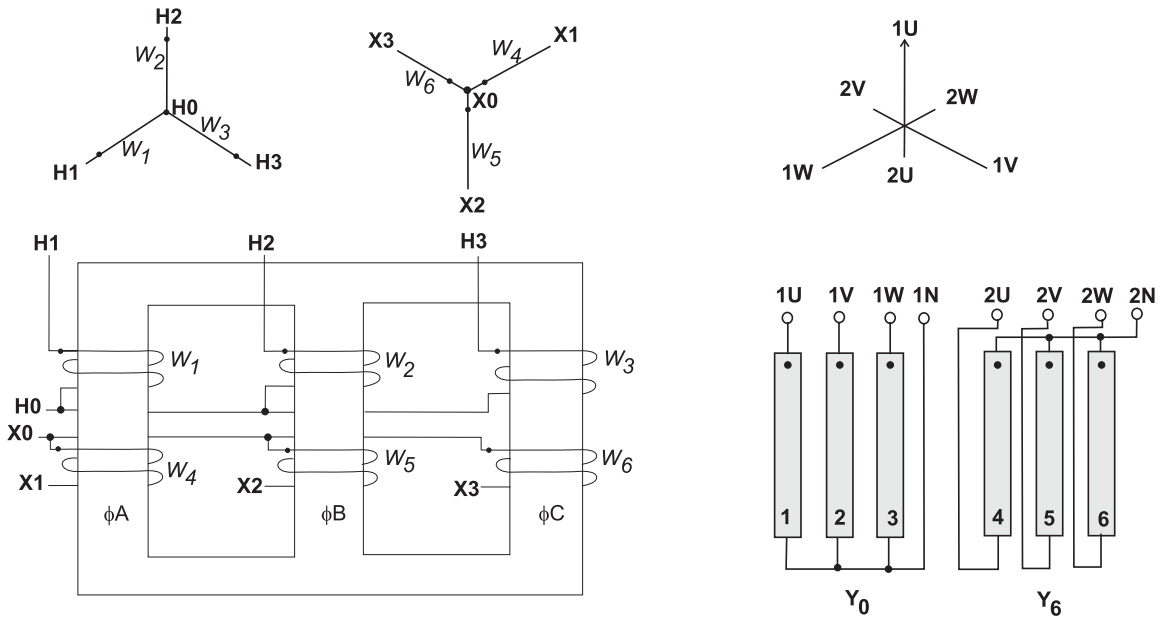

Figure 9 - Yy6 ($Y_0 - Y_6$)

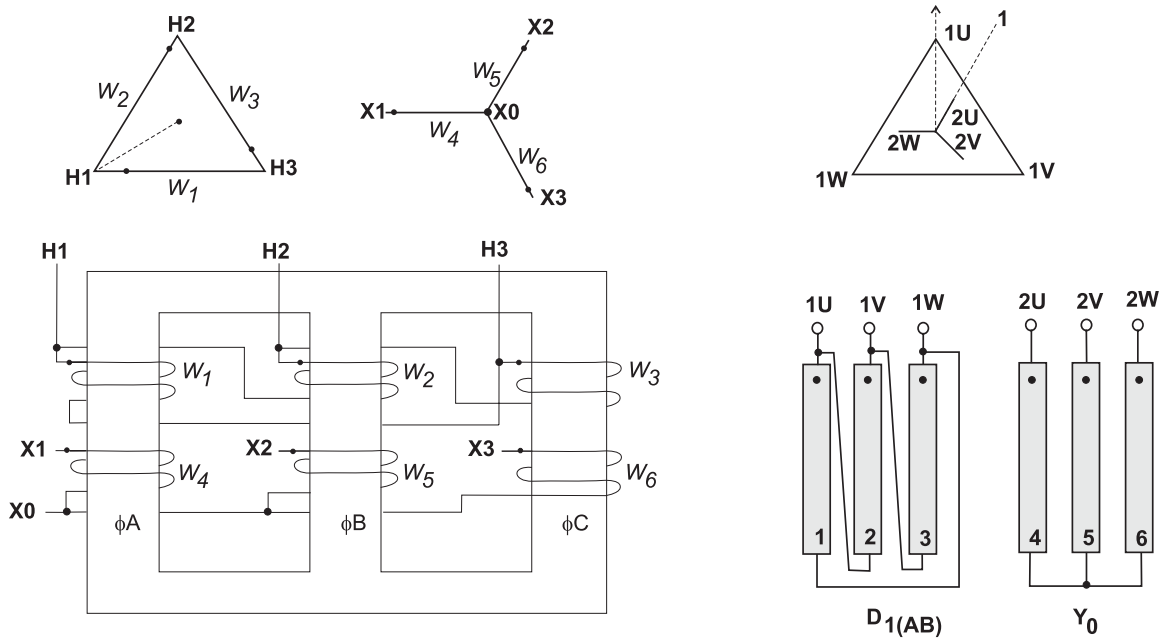

Figure 10 - Dy1 ($D_{1(=AB)} - Y_0$)

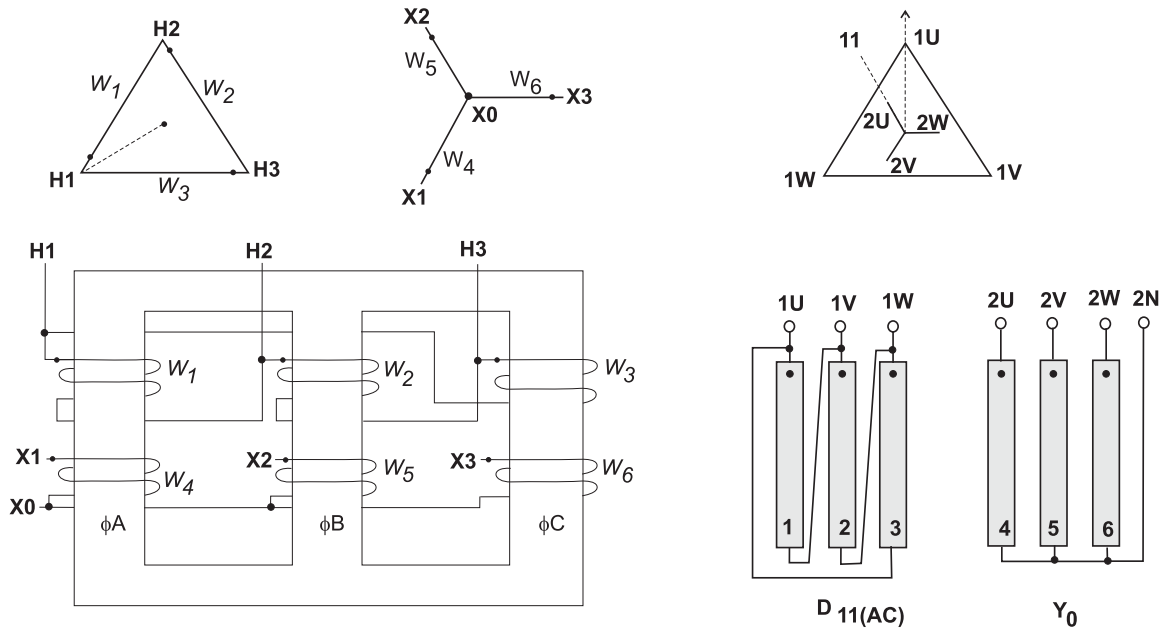

Figure 11 - Dy11 ($D_{11(=AC)} - Y_0$)

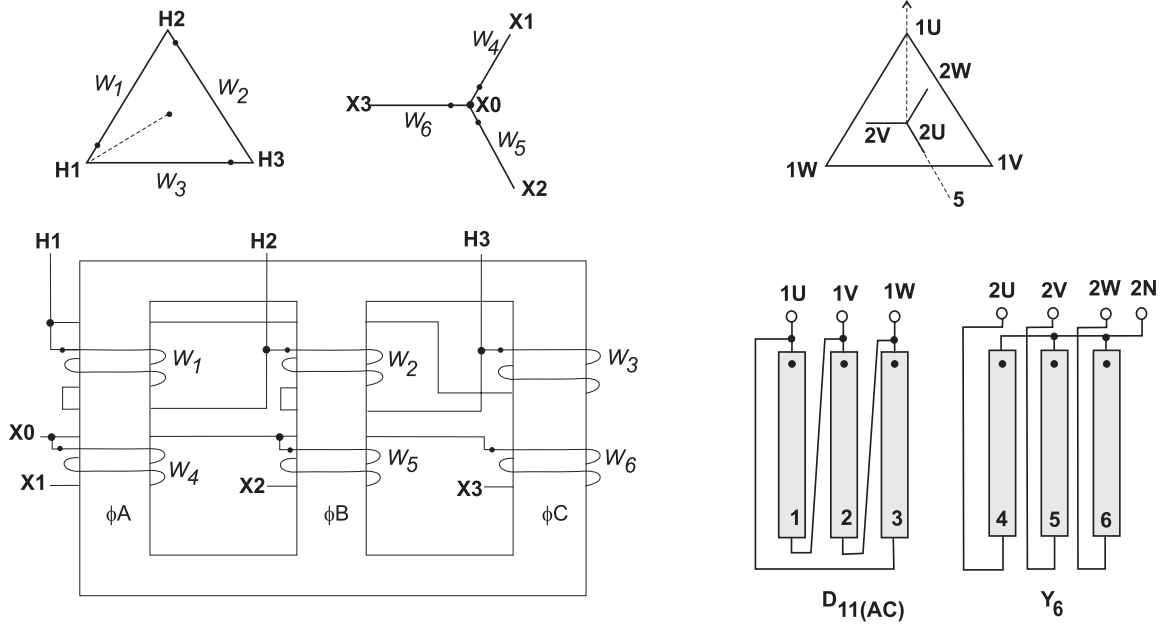

Figure 12 - Dy5 ($D_{11(=AC)} - Y_6$)

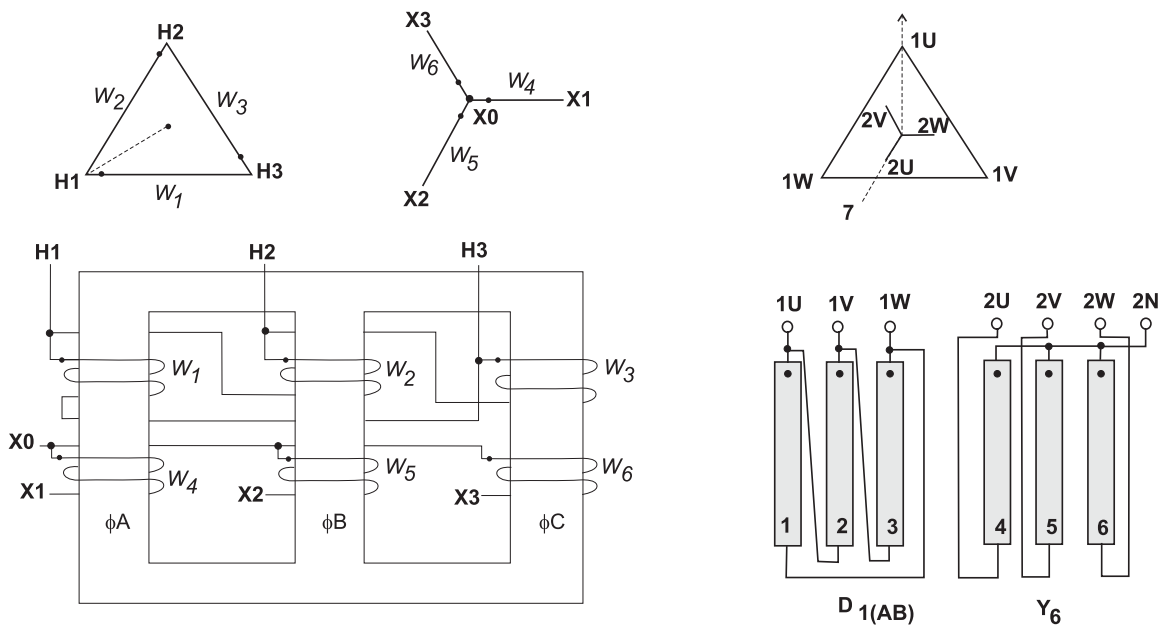

Figure 13 - Dy7 ($D_{1(=AB)} - Y_6$)

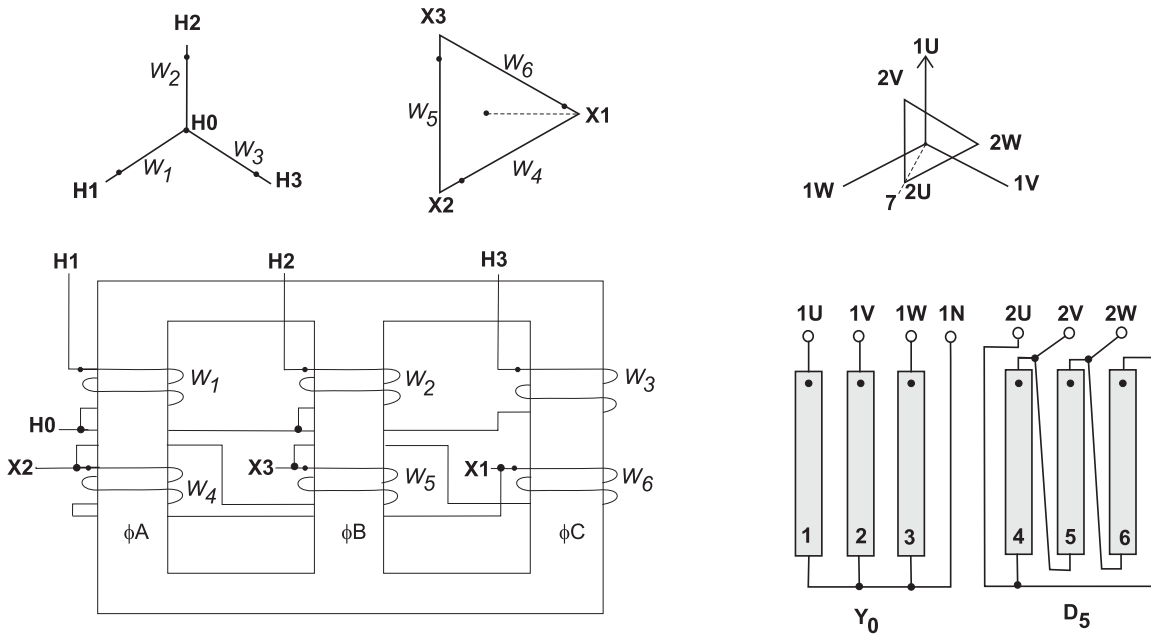

Figure 14 - Yd7 ($Y_0 - D_5$)

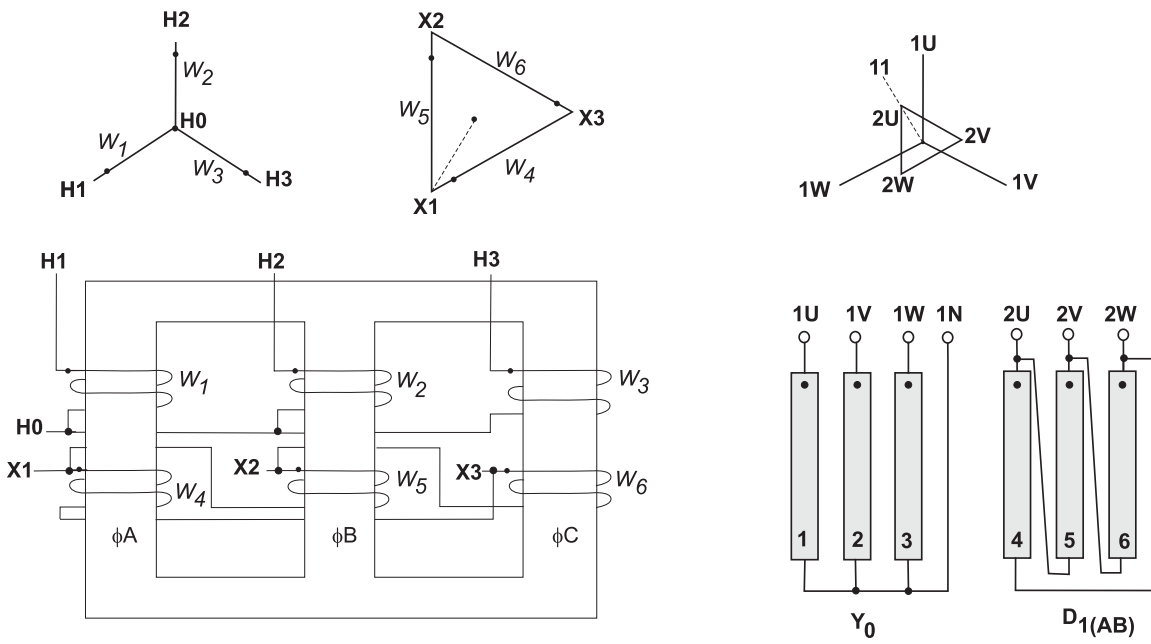

Figure 15 - Yd11 ($Y_0 - D_{1(=AB)}$)

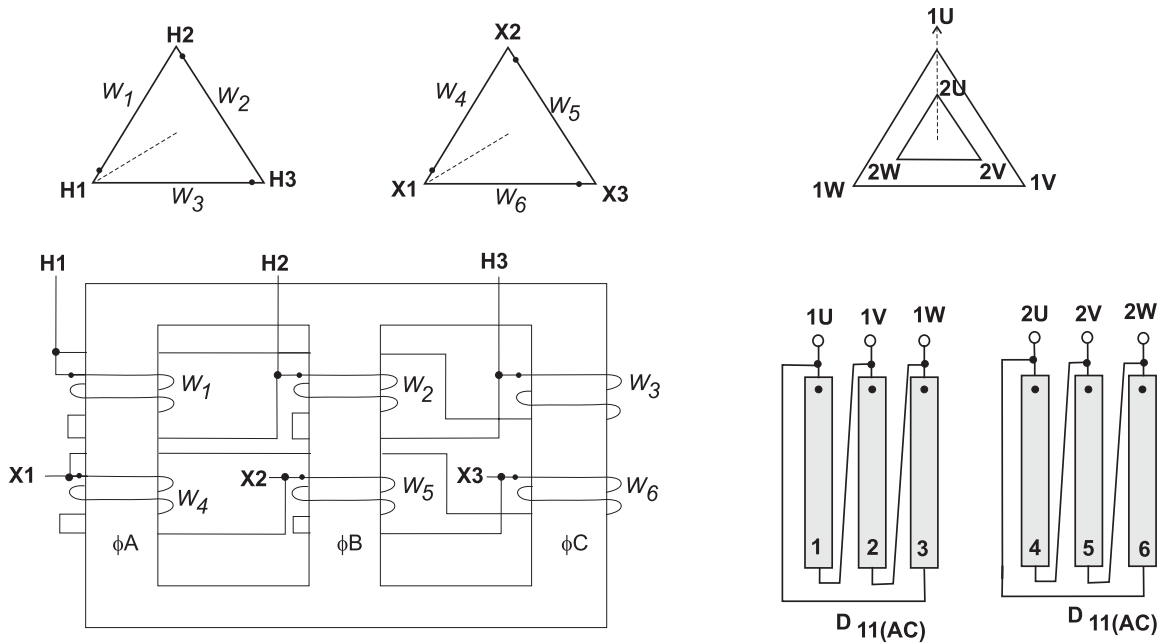

Figure 16 - Dd0 (D₁₁ - D₁₁)

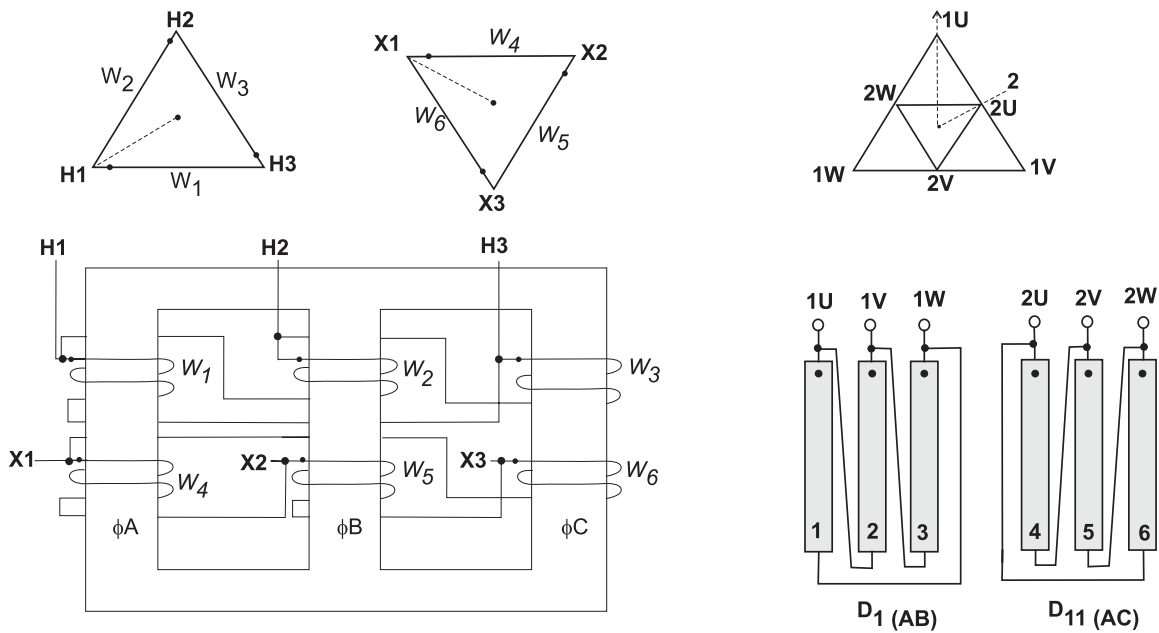

Figure 17 - Dd2 (D_{1(=AB)} - D₁₁)

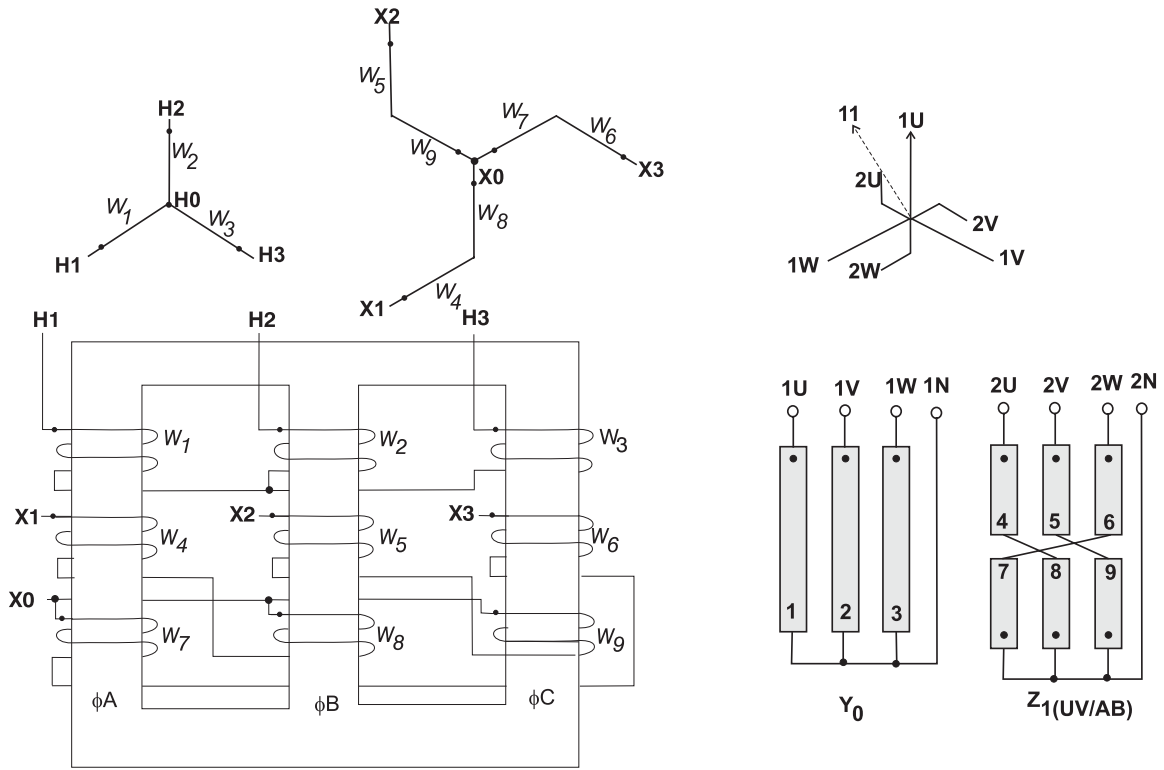

Figure 18 - Yz11 ($Y_0 - Z_1(UV/AB)$)

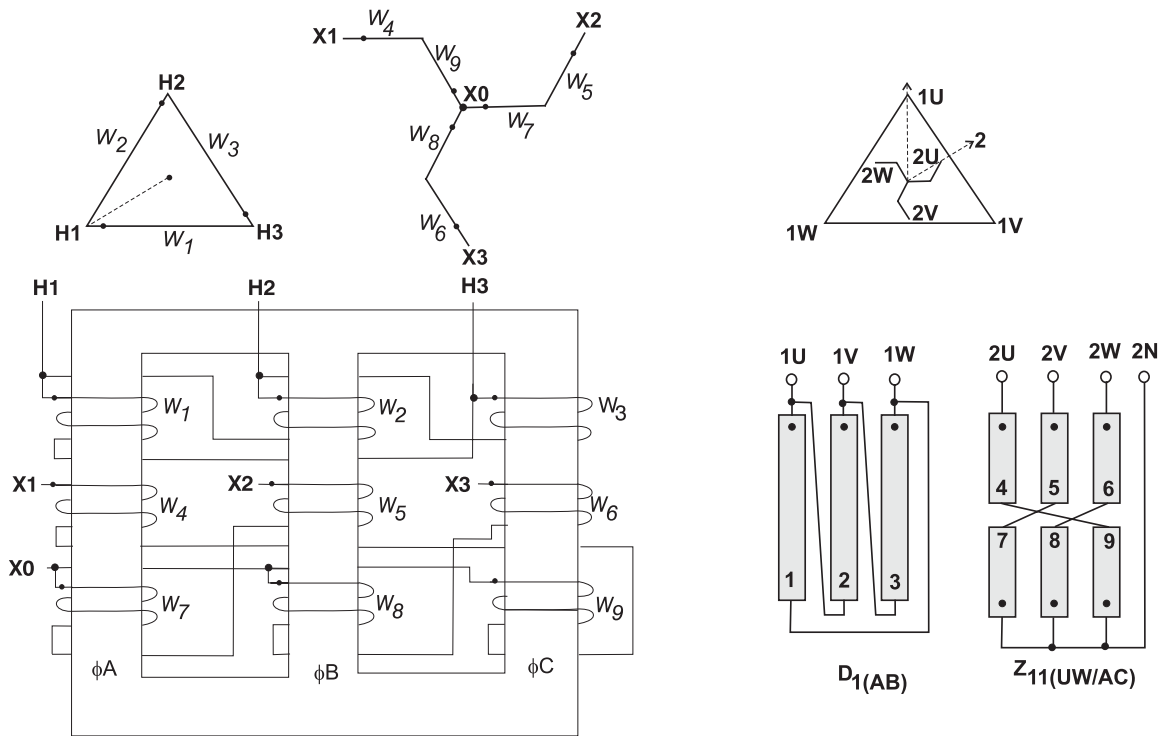
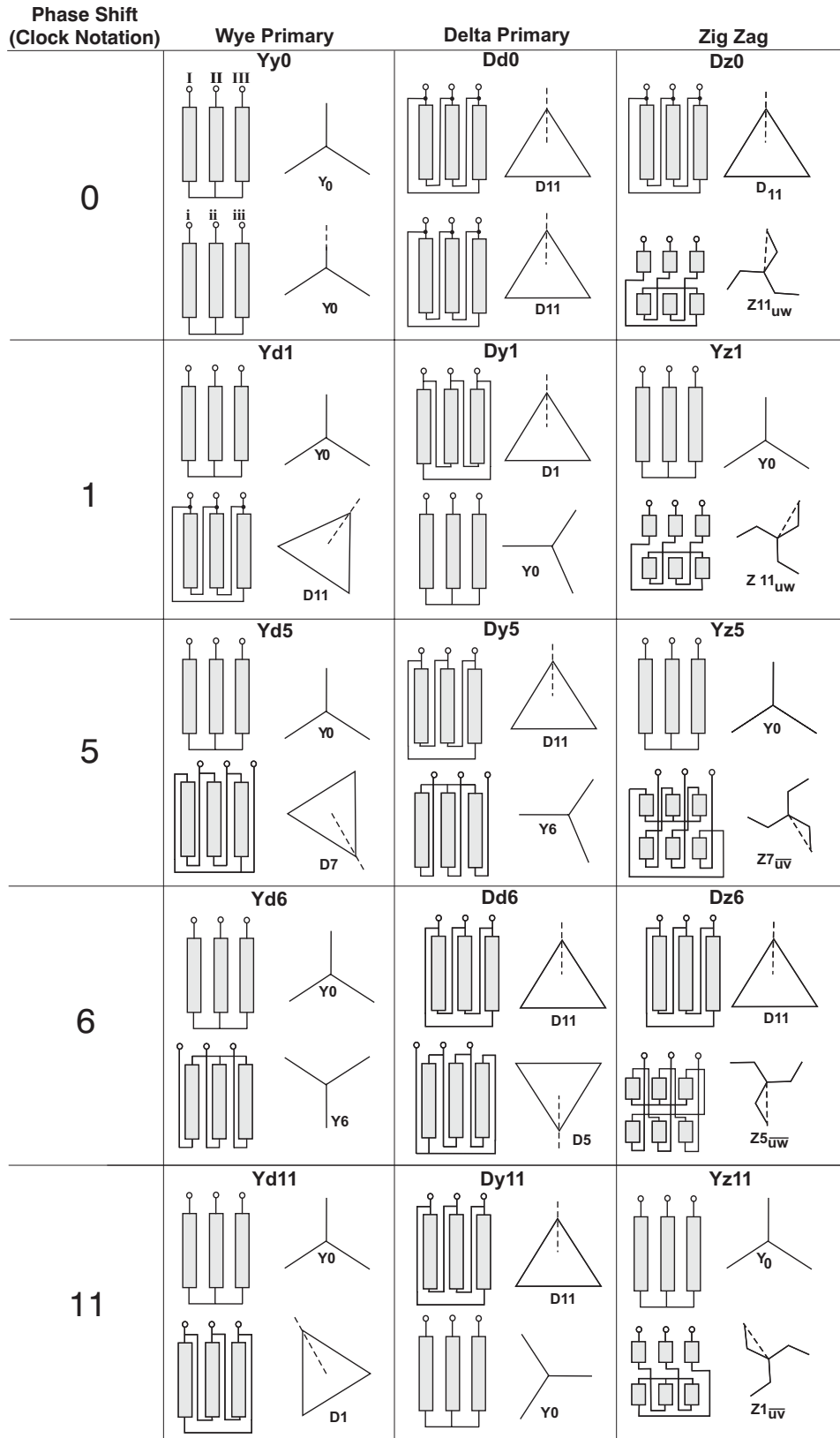
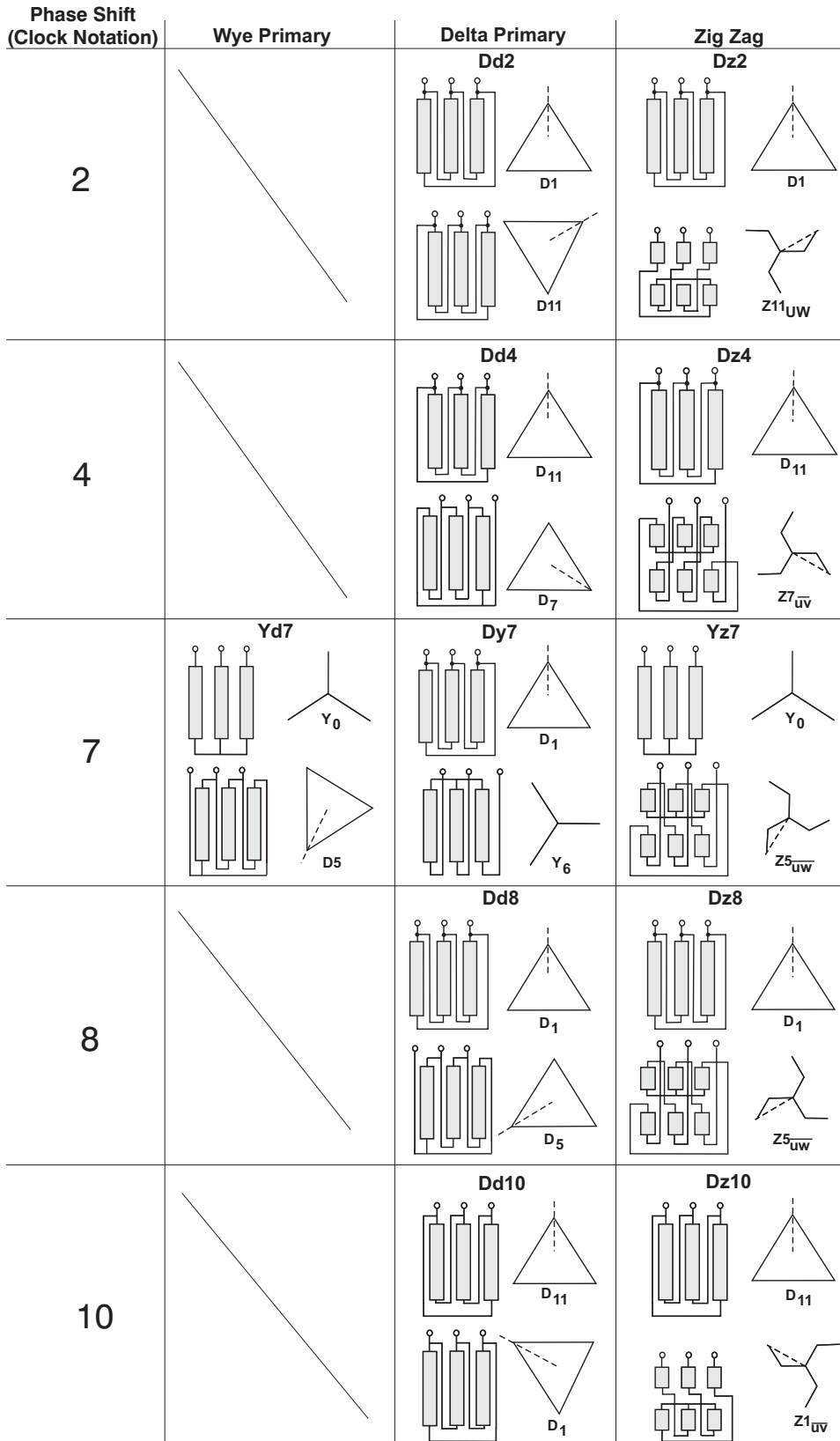

Figure 19 - Dz2 ($D_{1(=AB)} - Z_{11}(UW/AC)$)



Note: Polarity mark is to top of winding in these figures.

Figure 20 – Common connections (IEC 60076-1).



Note: Polarity mark is to top of winding in these figures.

Figure 21 – Additional connections (IEC 60076-1).

Differential Relay Current Balance Equations

Modern numeric transformer differential relays need to be able to work with the many permutations of how a transformer could be configured, as well as work with connecting the CTs in delta. The practice of connecting CTs in delta is usually unnecessary when a multifunction microprocessor based differential relay is utilized. However, in retrofit applications there is some tendency to leave existing wiring in place, which results in continued use of delta CT connections (e.g., when the 4th wire required to connect CTs in wye was not provided in the original installation).

To see how relays work with any form of transformer or CTs, the paper will work toward viewing a transformer differential relay as a device that monitors flux balance on each transformer leg, looking only at the flux due to load level, or higher, currents. Except for inrush conditions, excitation current is too small (<3% of self cooled current ratings) to be seen by the differential relay, so the relay sees only the load or fault level currents and effectively monitors that the flux this load current produces balances to zero. In normal operation, on a per phase basis, the flux created by the load current on a given winding will be countered by an equal and opposite flux created by the source winding on that same transformer leg, for a net of no change in flux levels in the leg relative to normal excitation levels. The matter of flux not summing to zero on a leg due to power transfer between phases due to magnetic coupling between phases (and in the case of zigzag windings, due to winding interconnections) was discussed at the start of the paper, under “Basic Transformer Design Concepts,” and also under the description of zigzag windings.

The flux that would be associated with load level currents on any one winding, and calculated via the equations to follow, would be on the order of a hundred times the current required to saturate the transformer. Fault currents would be even a higher multiple. However, since for any current/flux on one phase an opposite current/flux arises on another phase so that transformer net flux remains at normal excitation levels, saturation does not occur.

Let us apply the flux balance equation to a transformer with 3 phases, 6 windings, and two winding sets, primary and secondary. Each winding will produce a flux that is proportionate to its load current. The flux levels will be:

$$\begin{aligned} \phi_1 &= N_{Pr1} k_C I_1 & \phi_4 &= N_{Sec} k_C I_4 \\ \phi_2 &= N_{Pr1} k_C I_2 & \phi_5 &= N_{Sec} k_C I_5 \\ \phi_3 &= N_{Pr1} k_C I_3 & \phi_6 &= N_{Sec} k_C I_6 \end{aligned} \quad (1)$$

where N_1 and N_2 are the number of turns in winding set 1 and 2, and k_C is a proportionality constant that would be specific to the core, most notably the cross sectional dimensions and permeability. This k_C factor will cancel out of the current differential equations so we do not need to know its specific value. We can invert the concepts of (1) to state the current in terms of the core flux in each leg of the transformer, and we can start to introduce matrix representations of the equations. For winding set W_{123} :

$$\begin{bmatrix} I_{W1} \\ I_{W2} \\ I_{W3} \end{bmatrix} = \begin{bmatrix} k_{\phi1} & 0 & 0 \\ 0 & k_{\phi1} & 0 \\ 0 & 0 & k_{\phi1} \end{bmatrix} \begin{bmatrix} \phi_1 \\ \phi_2 \\ \phi_3 \end{bmatrix} \quad (2)$$

where:

$$k_{\phi 1} = \frac{1}{N_{Pri} k_C} \quad (3)$$

The equations for W_{456} are similar. In a condensed matrix math form, (2) becomes more compact:

$$\mathbf{I}_{123} = \mathbf{k}_{\phi, Pri} \times \boldsymbol{\Phi}_{123} \quad (4)$$

This format will be used extensively in the coming material. It might be noted that when an equation is bold it indicates that the elements in the equation represent matrices, not simply constants. Also, a bold multiplication symbol, \times , indicates the multiplication of matrices using appropriate matrix math.

Recall the above equations are referring to load flux, not excitation flux. For load induced flux, we can assume that in each leg of the transformer the flux that is caused by load current sums to 0 in normal operation. The equations are:

$$\begin{aligned} \text{Phase Leg 1: } \phi_{W1} + \phi_{W4} &= 0 \\ \text{Phase Leg 2: } \phi_{W2} + \phi_{W5} &= 0 \\ \text{Phase Leg 3: } \phi_{W3} + \phi_{W6} &= 0 \end{aligned} \quad (5)$$

The equation assumes the summation (not the difference) of the flux is zero. There is a parallel with how currents will be handled. In the equations to come, we will assume a positive current generates positive flux, so in the current differential function, the error current is the summation of currents coming into the relay.

Using the abbreviated matrix form of (3) this equality can be stated as:

$$\boldsymbol{\Phi}_{123} + \boldsymbol{\Phi}_{456} = \mathbf{0} \quad (6)$$

or alternatively, we can say that on each leg that the ratio of flux from the two core flux sources (e.g., W_1 and W_4) is -1.

The current that is delivered by the transformer is the flux times the appropriate k_{ϕ} factor (2). This current on the two sides of the transformer will differ in the inverse of the transformer turns ratio (3) so we need to multiply across by the turns ratio in the manner seen below. Using the abbreviated form of (4) and (6) the equation that represents normal operation is:

$$\left[\mathbf{N}_{Pri} \times \mathbf{k}_{\phi 1} \times \boldsymbol{\Phi}_{123} \right] + \left[\mathbf{N}_{Sec} \times \mathbf{k}_{\phi 2} \times \boldsymbol{\Phi}_{456} \right] = \mathbf{0} \quad (7)$$

Putting this equation into a more recognizable form, if we expand (7) and cancel the common k_C factor from (3) we obtain the current balance equation:

$$\begin{aligned} N_{Pri} I_{W1} + N_{Sec} I_{W4} &= 0 \\ N_{Pri} I_{W2} + N_{Sec} I_{W5} &= 0 \\ N_{Pri} I_{W3} + N_{Sec} I_{W6} &= 0 \end{aligned} \quad (8)$$

In a wye/wye transformer with no phase shift of positive sequence voltages and currents, Yy0, the bushing currents are equal to the winding currents ($I_{1U} = I_{W1}$, $I_{1V} = I_{W2}$, $I_{1W} = I_{W3}$, $I_{2U} = I_{W4}$, $I_{2V} = I_{W5}$, and $I_{2W} = I_{W6}$), equation (8) tells us how to sense flux balance. The balanced condition can be directly measured by a differential relay that only monitors by a simple ratio difference. (A real world transformer differential relay would also need to have a “block for inrush detection” algorithm as well.)

For any other winding or CT configuration than Yy0 we need a systematic method of creating “phase compensation” equations so that various combined or inverted winding currents on the relay inputs will be recognized as a balanced condition. To proceed, we need to determine the current seen at the transformer bushings and the relay for any given winding and CT configuration.

Negative Sequence Transformation

Before proceeding, some acknowledgement should be given to the fact that there are even more possible wye and delta connections than listed, if one opens up the thought process of swapping two phases at a time rather than three, on only one side of the transformer, in which case one transforms positive sequence phase rotation to negative sequence phase rotation across the transformer. Since this transformation would not be done in normal practice, it was not considered in development of this paper.

Wye Winding Transformations

There are 6 ways to connect a wye winding, as described earlier. Each modifies the W_1 , W_2 , and W_3 (or $W_{4,5,6,etc.}$) current by some transformation factor. For instance, if we connect the **U**, **V**, and **W** bushings to the non-polarity side of windings W_1 , W_2 , and W_3 , respectively, as is done in the Y_6 connection, we have effectively multiplied all currents by -1. Each connection method has its own transformation effect.

The equations below state the effective transformation in a mathematical format. This format will be useful when there are several transformations in series and we need to multiply them together to find the total effect. The equations give the current that will be seen on bushings **U**, **V**, and **W** for a given current in W_1 , W_2 , and W_3 , but where current is stated in terms of $I_W = k_\phi \phi$. and k_ϕ is as given in (3). All equations relate I_{UVW} to ϕ_{123} because the flux generated by the load current on each leg is the common element for all winding sets.

There are six 3x3 matrices that represent how the winding currents could be transformed by the various wye connection. In the condensed matrix equations on the right side, it can be seen that only four matrix transformations, **1**, **-1**, **R₁**, and **R₂**, are needed to represent the 6 wye transformation matrices. The value of this reduction in possible transformations will become clearer when delta and zigzag windings are analyzed further below. The **R₁** and **R₂** transformations “rotate” the bushing and winding connections. Given currents I_1 , I_2 , and I_3 , the effect of each rotation is to say:

$$\begin{aligned} \mathbf{R}_1 \text{ (120}^\circ \text{ CCW shift): } & \quad I_1^{\text{new}} = I_3^{\text{old}} & \quad I_2^{\text{new}} = I_1^{\text{old}} & \quad I_3^{\text{new}} = I_2^{\text{old}} \\ \mathbf{R}_2 \text{ (120}^\circ \text{ CW shift): } & \quad I_1^{\text{new}} = I_2^{\text{old}} & \quad I_2^{\text{new}} = I_3^{\text{old}} & \quad I_3^{\text{new}} = I_1^{\text{old}} \end{aligned} \quad (9)$$

The matrix form of (9), **R₁** and **R₂**, will be seen in the equations to follow. In the equations to follow, note a positive flux generates a positive current.

Wye Transformations

$$\mathbf{Y}_0 \text{ (Direct connect): } \begin{bmatrix} I_U \\ I_V \\ I_W \end{bmatrix} = \begin{bmatrix} 1 & 0 & 0 \\ 0 & 1 & 0 \\ 0 & 0 & 1 \end{bmatrix} \begin{bmatrix} k_\phi & 0 & 0 \\ 0 & k_\phi & 0 \\ 0 & 0 & k_\phi \end{bmatrix} \begin{bmatrix} \phi_1 \\ \phi_2 \\ \phi_3 \end{bmatrix} \quad \mathbf{I}_{UVW} = \mathbf{1} \times \mathbf{k}_\phi \times \boldsymbol{\phi}_{123} \quad (10)$$

$$\mathbf{Y}_4 \text{ (R}_2 \text{ phase swap): } \begin{bmatrix} I_U \\ I_V \\ I_W \end{bmatrix} = \begin{bmatrix} 0 & 0 & 1 \\ 1 & 0 & 0 \\ 0 & 1 & 0 \end{bmatrix} \begin{bmatrix} k_\phi & 0 & 0 \\ 0 & k_\phi & 0 \\ 0 & 0 & k_\phi \end{bmatrix} \begin{bmatrix} \phi_1 \\ \phi_2 \\ \phi_3 \end{bmatrix} \quad \mathbf{I}_{UVW} = \mathbf{R}_2 \times \mathbf{k}_\phi \times \boldsymbol{\phi}_{123} \quad (11)$$

$$\mathbf{Y}_8 \text{ (R}_1 \text{ phase swap): } \begin{bmatrix} I_U \\ I_V \\ I_W \end{bmatrix} = \begin{bmatrix} 0 & 1 & 0 \\ 0 & 0 & 1 \\ 1 & 0 & 0 \end{bmatrix} \begin{bmatrix} k_\phi & 0 & 0 \\ 0 & k_\phi & 0 \\ 0 & 0 & k_\phi \end{bmatrix} \begin{bmatrix} \phi_1 \\ \phi_2 \\ \phi_3 \end{bmatrix} \quad \mathbf{I}_{UVW} = \mathbf{R}_1 \times \mathbf{k}_\phi \times \boldsymbol{\phi}_{123} \quad (12)$$

$$\mathbf{Y}_6 \text{ (Negated } \mathbf{Y}_0 \text{): } \begin{bmatrix} I_U \\ I_V \\ I_W \end{bmatrix} = \begin{bmatrix} -1 & 0 & 0 \\ 0 & -1 & 0 \\ 0 & 0 & -1 \end{bmatrix} \begin{bmatrix} k_\phi & 0 & 0 \\ 0 & k_\phi & 0 \\ 0 & 0 & k_\phi \end{bmatrix} \begin{bmatrix} \phi_1 \\ \phi_2 \\ \phi_3 \end{bmatrix} \quad \mathbf{I}_{UVW} = -\mathbf{1} \times \mathbf{k}_\phi \times \boldsymbol{\phi}_{123} \quad (13)$$

$$\mathbf{Y}_2 \text{ (Negated } \mathbf{Y}_8 \text{): } \begin{bmatrix} I_U \\ I_V \\ I_W \end{bmatrix} = \begin{bmatrix} 0 & -1 & 0 \\ 0 & 0 & -1 \\ -1 & 0 & 0 \end{bmatrix} \begin{bmatrix} k_\phi & 0 & 0 \\ 0 & k_\phi & 0 \\ 0 & 0 & k_\phi \end{bmatrix} \begin{bmatrix} \phi_1 \\ \phi_2 \\ \phi_3 \end{bmatrix} \quad \mathbf{I}_{UVW} = -\mathbf{1} \times \mathbf{R}_1 \times \mathbf{k}_\phi \times \boldsymbol{\phi}_{123} \quad (14)$$

$$\mathbf{Y}_{10} \text{ (Negated } \mathbf{Y}_4 \text{): } \begin{bmatrix} I_U \\ I_V \\ I_W \end{bmatrix} = \begin{bmatrix} 0 & 0 & -1 \\ -1 & 0 & 0 \\ 0 & -1 & 0 \end{bmatrix} \begin{bmatrix} k_\phi & 0 & 0 \\ 0 & k_\phi & 0 \\ 0 & 0 & k_\phi \end{bmatrix} \begin{bmatrix} \phi_1 \\ \phi_2 \\ \phi_3 \end{bmatrix} \quad \mathbf{I}_{UVW} = -\mathbf{1} \times \mathbf{R}_2 \times \mathbf{k}_\phi \times \boldsymbol{\phi}_{123} \quad (15)$$

where k_ϕ is as defined by (3) for the particular winding.

Note that every matrix can be written of as the negative of one of the other matrices in the list, as noted in the left column. If one says a negated transformation matrix is not unique, there are really only 3 unique matrices above.

Delta Winding Transformations

If we connect a winding in delta, the current seen by the relay is a summation of two phase currents. There are two basic forms of a delta, D_1 connection (i.e., a D_{AB} connection), and a D_{11} connection (i.e., a D_{AC} connection). Given currents I_1 , I_2 , and I_3 :

$$\begin{aligned} D_{1(AB)} : \quad & I_1^{\text{new}} = I_1^{\text{old}} - I_2^{\text{old}} & I_2^{\text{new}} = I_2^{\text{old}} - I_3^{\text{old}} & I_3^{\text{new}} = I_3^{\text{old}} - I_1^{\text{old}} \\ D_{11(AC)} : \quad & I_1^{\text{new}} = I_1^{\text{old}} - I_3^{\text{old}} & I_2^{\text{new}} = I_2^{\text{old}} - I_1^{\text{old}} & I_3^{\text{new}} = I_3^{\text{old}} - I_2^{\text{old}} \end{aligned} \quad (16)$$

Phase swaps (\mathbf{R}_1 and \mathbf{R}_2 , above) combine with the above connections to create 6 different ways to connect a delta. A mathematical way to say the effect of the 6 possible delta connections on net phase current is given below. As with the wye connections, there are six 3x3 matrices that

represent how the winding currents could be transformed by the various delta connections. To perform all transformations listed below, two additional matrix transformation operations, \mathbf{D}_1 and \mathbf{D}_2 , are needed over what was introduced for the wye transformations. Actually, only one of these is required. Any \mathbf{D}_1 (or \mathbf{D}_{11}) transformation can be restated in terms of a \mathbf{D}_{11} (or \mathbf{D}_1) operation. For instance, $\mathbf{D}_1 = -\mathbf{1} \times \mathbf{R}_1 \times \mathbf{D}_{11}$ (compare (17) and (22), below).

Delta Transformations

$$\mathbf{D}_1 (\mathbf{D}_{AB}): \begin{bmatrix} I_U \\ I_V \\ I_W \end{bmatrix} = \begin{bmatrix} 1 & -1 & 0 \\ 0 & 1 & -1 \\ -1 & 0 & 1 \end{bmatrix} \begin{bmatrix} k_\phi & 0 & 0 \\ 0 & k_\phi & 0 \\ 0 & 0 & k_\phi \end{bmatrix} \begin{bmatrix} \phi_1 \\ \phi_2 \\ \phi_3 \end{bmatrix} \quad \mathbf{I}_{UVW} = \mathbf{D}_1 \times \mathbf{k}_\phi \times \boldsymbol{\phi}_{123} \quad (17)$$

$$\mathbf{D}_5 (\mathbf{D}_1 \times \mathbf{R}_2 \text{ swap}): \begin{bmatrix} I_U \\ I_V \\ I_W \end{bmatrix} = \begin{bmatrix} -1 & 0 & 1 \\ 1 & -1 & 0 \\ 0 & 1 & -1 \end{bmatrix} \begin{bmatrix} k_\phi & 0 & 0 \\ 0 & k_\phi & 0 \\ 0 & 0 & k_\phi \end{bmatrix} \begin{bmatrix} \phi_1 \\ \phi_2 \\ \phi_3 \end{bmatrix} \quad \mathbf{I}_{UVW} = \mathbf{R}_2 \times \mathbf{D}_1 \times \mathbf{k}_\phi \times \boldsymbol{\phi}_{123} \quad (18)$$

$$\mathbf{D}_9 (\mathbf{D}_1 \times \mathbf{R}_1 \text{ swap}): \begin{bmatrix} I_U \\ I_V \\ I_W \end{bmatrix} = \begin{bmatrix} 0 & 1 & -1 \\ -1 & 0 & 1 \\ 1 & -1 & 0 \end{bmatrix} \begin{bmatrix} k_\phi & 0 & 0 \\ 0 & k_\phi & 0 \\ 0 & 0 & k_\phi \end{bmatrix} \begin{bmatrix} \phi_1 \\ \phi_2 \\ \phi_3 \end{bmatrix} \quad \mathbf{I}_{UVW} = \mathbf{R}_1 \times \mathbf{D}_1 \times \mathbf{k}_\phi \times \boldsymbol{\phi}_{123} \quad (19)$$

$$\mathbf{D}_{11} (\mathbf{D}_{AC}): \begin{bmatrix} I_U \\ I_V \\ I_W \end{bmatrix} = \begin{bmatrix} 1 & 0 & -1 \\ -1 & 1 & 0 \\ 0 & -1 & 1 \end{bmatrix} \begin{bmatrix} k_\phi & 0 & 0 \\ 0 & k_\phi & 0 \\ 0 & 0 & k_\phi \end{bmatrix} \begin{bmatrix} \phi_1 \\ \phi_2 \\ \phi_3 \end{bmatrix} \quad \mathbf{I}_{UVW} = \mathbf{D}_{11} \times \mathbf{k}_\phi \times \boldsymbol{\phi}_{123} \quad (20)$$

$$\mathbf{D}_3 (\mathbf{D}_{11} \times \mathbf{R}_2 \text{ swap}): \begin{bmatrix} I_U \\ I_V \\ I_W \end{bmatrix} = \begin{bmatrix} 0 & -1 & 1 \\ 1 & 0 & -1 \\ -1 & 1 & 0 \end{bmatrix} \begin{bmatrix} k_\phi & 0 & 0 \\ 0 & k_\phi & 0 \\ 0 & 0 & k_\phi \end{bmatrix} \begin{bmatrix} \phi_1 \\ \phi_2 \\ \phi_3 \end{bmatrix} \quad \mathbf{I}_{UVW} = \mathbf{R}_2 \times \mathbf{D}_{11} \times \mathbf{k}_\phi \times \boldsymbol{\phi}_{123} \quad (21)$$

$$\mathbf{D}_7 (\mathbf{D}_{11} \times \mathbf{R}_1 \text{ swap}): \begin{bmatrix} I_U \\ I_V \\ I_W \end{bmatrix} = \begin{bmatrix} -1 & 1 & 0 \\ 0 & -1 & 1 \\ 1 & 0 & -1 \end{bmatrix} \begin{bmatrix} k_\phi & 0 & 0 \\ 0 & k_\phi & 0 \\ 0 & 0 & k_\phi \end{bmatrix} \begin{bmatrix} \phi_1 \\ \phi_2 \\ \phi_3 \end{bmatrix} \quad \mathbf{I}_{UVW} = \mathbf{R}_1 \times \mathbf{D}_{11} \times \mathbf{k}_\phi \times \boldsymbol{\phi}_{123} \quad (22)$$

where k_ϕ is as defined by (3) for the particular winding.

Similar to what was seen for the wye connections, one might say that there are only 3 unique matrices above. Every one can be written of as the negative of one of the other matrices in the list.

For eventual calculation of the overall transformation equations we will need to know the transformer turns ratio. Referring to figures 10 and 16 for winding numbers, in a delta/wye and delta/delta transformer, the turns ratios are:

$$\begin{aligned}
\text{Dy Turns Ratio: } R_{Dy} &= \frac{N_{W1}}{N_{W4}} = \sqrt{3} \frac{V_{D,LL}}{V_{y,LL}} \\
\text{Dd Turns Ratio: } R_{Dd} &= \frac{N_{W1}}{N_{W4}} = \frac{V_{D,LL}}{V_{d,LL}}
\end{aligned} \tag{23}$$

Double Delta Transformations

A double delta refers to the case where there are two delta transformations in series. We can simplify the equations somewhat by pre-multiplying the two matrices together. Some examples of double delta transformation matrices include:

$$\mathbf{DD}_{1x1} = \mathbf{D}_1 \times \mathbf{D}_1 = \begin{bmatrix} 1 & -1 & 0 \\ 0 & 1 & -1 \\ -1 & 0 & 1 \end{bmatrix} \cdot \begin{bmatrix} 1 & -1 & 0 \\ 0 & 1 & -1 \\ -1 & 0 & 1 \end{bmatrix} = \begin{bmatrix} 1 & -2 & 1 \\ 1 & 1 & -2 \\ -2 & 1 & 1 \end{bmatrix} \tag{24}$$

$$\mathbf{DD}_{1x11} = \mathbf{D}_1 \times \mathbf{D}_{11} = \begin{bmatrix} 1 & -1 & 0 \\ 0 & 1 & -1 \\ -1 & 0 & 1 \end{bmatrix} \cdot \begin{bmatrix} 1 & 0 & -1 \\ -1 & 1 & 0 \\ 0 & -1 & 1 \end{bmatrix} = \begin{bmatrix} 2 & -1 & -1 \\ -1 & 2 & -1 \\ -1 & -1 & 2 \end{bmatrix} = -\mathbf{1} \times \mathbf{R}_2 \times \mathbf{DD}_{1x1} \tag{25}$$

$$\mathbf{DD}_{11x11} = \mathbf{D}_{11} \times \mathbf{D}_{11} = \begin{bmatrix} 1 & 0 & -1 \\ -1 & 1 & 0 \\ 0 & -1 & 1 \end{bmatrix} \cdot \begin{bmatrix} 1 & 0 & -1 \\ -1 & 1 & 0 \\ 0 & -1 & 1 \end{bmatrix} = \begin{bmatrix} 1 & 1 & -2 \\ -2 & 1 & 1 \\ 1 & -2 & 1 \end{bmatrix} = \mathbf{R}_1 \times \mathbf{DD}_{1x1} \tag{26}$$

Note the double deltas found in normal practice can be redefined as a combination of \mathbf{DD}_{1x1} , \mathbf{R}_1 , \mathbf{R}_2 , and $-\mathbf{1}$ transformation factors.

The double delta transformation does not arise too often, but it is physically possible, does occur, and is easy enough for relay compensation. Targeting and relay testing will be especially problematic whenever a double delta is utilized because current on any phase is seen in all the differential comparators.

Zigzag Winding Transformations

To analyze current across a zigzag winding, let us continue to assume that, in balanced conditions, all load flux in each leg sums to zero.

Use the Z_{1UV} transformer of Figure 7 for our discussion (one can also refer to Figure 18) and assume the flux on the primary winding set will be named $\phi_{U,V,W}$. Taking into account that $\phi_{W4,5,6}$ can be restated in terms of their equivalent $\phi_{W1,2,3}$ the flux balance says that:

$$\begin{aligned}
\phi_{U,Pr1} + \phi_{W1} - \phi_{W3} &= 0 \\
\phi_{V,Pr1} + \phi_{W2} - \phi_{W1} &= 0 \\
\phi_{W,Pr1} + \phi_{W3} - \phi_{W2} &= 0
\end{aligned} \tag{27}$$

Let us convert the flux to the equivalent current equations, using (1). We have:

$$\begin{aligned}
N_{Pri}k_C I_{U,Pri} + N_Z k_C (I_{U,Z} - I_{W,Z}) &= 0 \\
N_{Pri}k_C I_{V,Pri} + N_Z k_C (I_{V,Z} - I_{U,Z}) &= 0 \\
N_{Pri}k_C I_{W,Pri} + N_Z k_C (I_{W,Z} - I_{V,Z}) &= 0
\end{aligned} \tag{28}$$

Solving (25) for $I_{UVW, primary}$:

$$\begin{aligned}
I_{U,Pri} &= -\frac{N_Z}{N_{Pri}} (I_{U,Z} - I_{W,Z}) \\
I_{V,Pri} &= -\frac{N_Z}{N_{Pri}} (I_{V,Z} - I_{U,Z}) \\
I_{W,Pri} &= -\frac{N_Z}{N_{Pri}} (I_{W,Z} - I_{V,Z})
\end{aligned} \tag{29}$$

Expressing this in matrix form:

$$\begin{bmatrix} I_{U,Pri} \\ I_{V,Pri} \\ I_{W,Pri} \end{bmatrix} = -\frac{N_Z}{N_{Pri}} \begin{bmatrix} 1 & 0 & -1 \\ -1 & 1 & 0 \\ 0 & -1 & 1 \end{bmatrix} \begin{bmatrix} I_{U,Z} \\ I_{V,Z} \\ I_{W,Z} \end{bmatrix} \tag{30}$$

The analysis will start by viewing the Z winding set side as an effective wye connection; terminal current is equal to winding current. We wish to see how the current will appear to the lines on the other side of the transformer. An examination of (29) and (30) will show that the primary will see the secondary in a fashion that is similar to a delta transformation.

Using equations (1) and (2), let us convert (30) to an equation closer to the format used for the wye and delta transformations earlier in the paper. Also note that when solving (28) for I_{Pri} we introduced a negative correlation between primary current and secondary current. We do not want the negative correlation. We want to have the concept of a positive flux creates a positive current on both windings, so we will introduce an "x -1" factor.

$$\begin{bmatrix} I_{U,Pri} \\ I_{V,Pri} \\ I_{W,Pri} \end{bmatrix} = \frac{N_Z}{N_{Pri}} \begin{bmatrix} 1 & 0 & -1 \\ -1 & 1 & 0 \\ 0 & -1 & 1 \end{bmatrix} \begin{bmatrix} k_{\phi,z} & 0 & 0 \\ 0 & k_{\phi,z} & 0 \\ 0 & 0 & k_{\phi,z} \end{bmatrix} \begin{bmatrix} \phi_{1(U,Z)} \\ \phi_{2(V,Z)} \\ \phi_{3(W,Z)} \end{bmatrix} \tag{31}$$

where $k_{\phi,z}=1/(N_Z k_C)$. Note that the matrix is the same as for a \mathbf{D}_{11} connection, typical of all the wye-zigzag connection transformations.

We can reorganize this to the form of the delta and wye winding equations. We need two different equations: one for the transformer as seen from the zigzag side bushings and one as seen from the primary side bushings. First, from the zigzag side, the current in the zigzag windings has the same transformation as a \mathbf{Y}_0 connection (though other $\mathbf{Y}_\#$ transformations are possible via phase swaps and winding connection reversals). From the high side we will have a variety of transformation equations that vary with how equations (27) through (30) work out for the particular configuration. If the primary is connected in delta, the equations have additional transformation factors, described below.

Zigzag Transformations, Seen From Zigzag Side

$$\mathbf{Z}_{Z \text{ Side}} \begin{bmatrix} I_{U,Z} \\ I_{V,Z} \\ I_{W,Z} \end{bmatrix} = \begin{bmatrix} 1 & 0 & 0 \\ 0 & 1 & 0 \\ 0 & 0 & 1 \end{bmatrix} \begin{bmatrix} k_{\phi,Z} & 0 & 0 \\ 0 & k_{\phi,Z} & 0 \\ 0 & 0 & k_{\phi,Z} \end{bmatrix} \begin{bmatrix} \phi_1 \\ \phi_2 \\ \phi_3 \end{bmatrix} \quad \mathbf{I}_{UVW} = \mathbf{1} \times \mathbf{k}_{\phi,Z} \times \boldsymbol{\phi}_{123} \quad (32)$$

where $k_{\phi,Z} = \frac{1}{N_Z k_C}$.

Phase swaps and winding connection reversal will affect the transformation equations by adding **-1**, **R₁**, and **R₂** transformation factors.

Zigzag Transformations, Seen From Wye Primary

$$\mathbf{Z}_1 (\mathbf{Z}_{AB/UV}): \begin{bmatrix} I_{U, Pri} \\ I_{V, Pri} \\ I_{W, Pri} \end{bmatrix} = \begin{bmatrix} 1 & 0 & -1 \\ -1 & 1 & 0 \\ 0 & -1 & 1 \end{bmatrix} \begin{bmatrix} k_{\phi, Pri} & 0 & 0 \\ 0 & k_{\phi, Pri} & 0 \\ 0 & 0 & k_{\phi, Pri} \end{bmatrix} \begin{bmatrix} \phi_1 \\ \phi_2 \\ \phi_3 \end{bmatrix} \quad \mathbf{I}_{UVW} = \mathbf{D}_{11} \times \mathbf{k}_{\phi, Pri} \times \boldsymbol{\phi}_{123} \quad (33)$$

$$\mathbf{Z}_7 (= -\mathbf{Z}_1): \begin{bmatrix} I_{U, Pri} \\ I_{V, Pri} \\ I_{W, Pri} \end{bmatrix} = \begin{bmatrix} -1 & 0 & 1 \\ 1 & -1 & 0 \\ 0 & 1 & -1 \end{bmatrix} \begin{bmatrix} k_{\phi, Pri} & 0 & 0 \\ 0 & k_{\phi, Pri} & 0 \\ 0 & 0 & k_{\phi, Pri} \end{bmatrix} \begin{bmatrix} \phi_1 \\ \phi_2 \\ \phi_3 \end{bmatrix} \quad \mathbf{I}_{UVW} = -\mathbf{1} \times \mathbf{D}_{11} \times \mathbf{k}_{\phi, Pri} \times \boldsymbol{\phi}_{123} \quad (34)$$

$$\mathbf{Z}_{11} (\mathbf{Z}_{AC/UW}): \begin{bmatrix} I_{U, Pri} \\ I_{V, Pri} \\ I_{W, Pri} \end{bmatrix} = \begin{bmatrix} 1 & -1 & 0 \\ 0 & 1 & -1 \\ -1 & 0 & 1 \end{bmatrix} \begin{bmatrix} k_{\phi, Pri} & 0 & 0 \\ 0 & k_{\phi, Pri} & 0 \\ 0 & 0 & k_{\phi, Pri} \end{bmatrix} \begin{bmatrix} \phi_1 \\ \phi_2 \\ \phi_3 \end{bmatrix} \quad \mathbf{I}_{UVW} = \mathbf{D}_1 \times \mathbf{k}_{\phi, Pri} \times \boldsymbol{\phi}_{123} \quad (35)$$

$$\mathbf{Z}_5 (= -\mathbf{Z}_{11}): \begin{bmatrix} I_{U, Pri} \\ I_{V, Pri} \\ I_{W, Pri} \end{bmatrix} = \begin{bmatrix} -1 & 1 & 0 \\ 0 & -1 & 1 \\ 1 & 0 & -1 \end{bmatrix} \begin{bmatrix} k_{\phi, Pri} & 0 & 0 \\ 0 & k_{\phi, Pri} & 0 \\ 0 & 0 & k_{\phi, Pri} \end{bmatrix} \begin{bmatrix} \phi_1 \\ \phi_2 \\ \phi_3 \end{bmatrix} \quad \mathbf{I}_{UVW} = -\mathbf{1} \times \mathbf{D}_1 \times \mathbf{k}_{\phi, Pri} \times \boldsymbol{\phi}_{123} \quad (36)$$

where $k_{\phi, Pri} = \frac{1}{N_{Pri} k_C}$.

Phase swaps and winding connection reversal will affect the transformation equations by adding **-1**, **R₁**, and **R₂** transformations.

Zigzag Transformations, Seen From D₁ Primary

The zigzag with a delta winding introduces the issue of back to back delta transformations. Since a zigzag is effectively a delta as seen from the primary, we will have a “double delta” transformation. The approach is to simply multiply the two delta effects together as was seen in the double delta discussions above. i.e., if a primary is connected in delta, we simply add the

appropriate delta transformation to the overall transformation equation. The equation can be simplified a bit using the $\mathbf{D}_1 \times \mathbf{D}_{11}$ transformation previously mentioned (25).

$$\mathbf{D}_1 \times \mathbf{Z}_1 (\mathbf{Z}_{UV}): \begin{bmatrix} I_{U, Pri} \\ I_{V, Pri} \\ I_{W, Pri} \end{bmatrix} = \begin{bmatrix} 2 & -1 & -1 \\ -1 & 2 & -1 \\ -1 & -1 & 2 \end{bmatrix} \begin{bmatrix} k_{\phi, Pri} & 0 & 0 \\ 0 & k_{\phi, Pri} & 0 \\ 0 & 0 & k_{\phi, Pri} \end{bmatrix} \begin{bmatrix} \phi_1 \\ \phi_2 \\ \phi_3 \end{bmatrix} \quad \mathbf{I}_{UVW} = \mathbf{D}_1 \times \mathbf{D}_{11} \times \mathbf{k}_{\phi} \times \boldsymbol{\phi}_{123} \quad (37)$$

$$\mathbf{D}_1 \times \mathbf{Z}_{11} (\mathbf{Z}_{UW}): \begin{bmatrix} I_{U, Pri} \\ I_{V, Pri} \\ I_{W, Pri} \end{bmatrix} = \begin{bmatrix} 1 & -2 & 1 \\ 1 & 1 & -2 \\ -2 & 1 & 1 \end{bmatrix} \begin{bmatrix} k_{\phi, Pri} & 0 & 0 \\ 0 & k_{\phi, Pri} & 0 \\ 0 & 0 & k_{\phi, Pri} \end{bmatrix} \begin{bmatrix} \phi_1 \\ \phi_2 \\ \phi_3 \end{bmatrix} \quad \mathbf{I}_{UVW} = \mathbf{D}_1 \times \mathbf{D}_1 \times \mathbf{k}_{\phi} \times \boldsymbol{\phi}_{123} \quad (38)$$

The reader can use this example to determine how a \mathbf{D}_{11} connection changes the equations.

For eventual calculation of overall transformation equations we will need to know the transformer turns ratio. Referring to Figure 18 and 19 for winding numbers and looking at the windings on one core leg, in a classical zigzag transformer, the turns ratios are:

$$\begin{aligned} N_{W4} &= N_{W7} \\ \text{Yz Ratio: } R_{Yz} &= \frac{N_{W1}}{N_{W4} \text{ or } N_{W7}} = \sqrt{3} \frac{V_{Y,LL}}{V_{Z,LL}} \\ \text{Dz Ratio: } R_{Dz} &= \frac{N_{W1}}{N_{W4} \text{ or } N_{W7}} = 3 \frac{V_{D,LL}}{V_{Z,LL}} \end{aligned} \quad (39)$$

As a side note, setting N_4 and N_7 different from one another allows a continuous variety of phase shifts across the transformer. Such transformers are used in harmonic cancellation techniques in VFD applications and in large phase shifting transformers used for power flow control in important transmission lines.

CT Connections Transformations

A wye CT is fairly straightforward and simply changes the transformer current by a specific ratio. A complication can occur if a CT connection is made backwards such that it adds a -1 factor to the current balance equation. This -1 factor might arise if one of the CT sets is connected backwards relative to the relay manufacturer's instruction manual.

$$\mathbf{Y}_{CT0}: \begin{bmatrix} I_{U, Relay} \\ I_{V, Relay} \\ I_{W, Relay} \end{bmatrix} = \begin{bmatrix} N_{CT} & 0 & 0 \\ 0 & N_{CT} & 0 \\ 0 & 0 & N_{CT} \end{bmatrix} \begin{bmatrix} I_U \\ I_V \\ I_W \end{bmatrix} \quad \mathbf{I}_{UVW, Relay} = \mathbf{N}_{CT} \times \mathbf{I}_{UVW} \quad (40)$$

$$\mathbf{Y}_{CT6}: \begin{bmatrix} I_{U, Relay} \\ I_{V, Relay} \\ I_{W, Relay} \end{bmatrix} = \begin{bmatrix} -N_{CT} & 0 & 0 \\ 0 & -N_{CT} & 0 \\ 0 & 0 & -N_{CT} \end{bmatrix} \begin{bmatrix} I_U \\ I_V \\ I_W \end{bmatrix} \quad \mathbf{I}_{UVW, Relay} = -1 \times \mathbf{N}_{CT} \times \mathbf{I}_{UVW} \quad (41)$$

where N_{CT} is a step-down factor of:

$$N_{CT} = \frac{I_{Sec}}{I_{Pri}} \quad (42)$$

A delta CT complicates the transformer differential relay compensation by adding a second delta transformation effect. A delta CT connection will virtually always be a D_1 or a D_{11} form transformation, but other connections are not impossible.

$$\mathbf{D}_{CT1} (\mathbf{D}_{AB}): \begin{bmatrix} I_{U,Relay} \\ I_{V,Relay} \\ I_{W,Relay} \end{bmatrix} = \begin{bmatrix} N_{CT} & 0 & 0 \\ 0 & N_{CT} & 0 \\ 0 & 0 & N_{CT} \end{bmatrix} \begin{bmatrix} 1 & -1 & 0 \\ 0 & 1 & -1 \\ -1 & 0 & 1 \end{bmatrix} \begin{bmatrix} I_U \\ I_V \\ I_W \end{bmatrix} \quad \mathbf{I}_{UVW,Relay} = N_{CT} \times \mathbf{D}_1 \times \mathbf{I}_{UVW} \quad (43)$$

$$\mathbf{D}_{CT11} (\mathbf{D}_{AC}): \begin{bmatrix} I_{U,Relay} \\ I_{V,Relay} \\ I_{W,Relay} \end{bmatrix} = \begin{bmatrix} N_{CT} & 0 & 0 \\ 0 & N_{CT} & 0 \\ 0 & 0 & N_{CT} \end{bmatrix} \begin{bmatrix} 1 & 0 & -1 \\ -1 & 1 & 0 \\ 0 & -1 & 1 \end{bmatrix} \begin{bmatrix} I_U \\ I_V \\ I_W \end{bmatrix} \quad \mathbf{I}_{UVW,Relay} = N_{CT} \times \mathbf{D}_{11} \times \mathbf{I}_{UVW} \quad (44)$$

It might be possible also to have reverse connected CTs that are then connected in delta, resulting in negated versions of \mathbf{D}_{CT1} and \mathbf{D}_{CT11} , creating \mathbf{D}_{CT7} and \mathbf{D}_{CT5} , respectively.

Net Compensation Equations

Relay Differential Comparator Equations

As previously discussed, the assumption is that when the transformer is operating correctly, the flux on each leg due to load current (or external fault current) sums to zero. A differential relay has three comparators. The three comparators compare through current (current sensed at each input) to error current (difference between the two through currents), ideally on each phase of the transformer, but when delta connections are between the relay and the transformer, delta summations are monitored instead. The details of what the relay does with the current it senses in the comparator is beyond the scope of the paper and varies with each relay manufacturer, but the current the comparator is monitoring is about the same in most current differential relays.

The error current equation below assumes the relay is configured in such a way that current into one winding set and out the other winding set results in positive current into one input of the relay and negative current (i.e., 180° phase shift) into the other input. The summation (not the difference) of the two currents would therefore normally be 0. This approach is in accordance with the previously described flux balance equation, (5). Hence, the three differential comparators in the relay monitor:

$$\begin{array}{ll} \mathbf{U} \text{ Comparator:} & \text{Through Current: } I_1^{\text{Compensated}} \text{ and } I_4^{\text{Compensated}} \\ & \text{Error Current: } I_1^{\text{Compensated}} + I_4^{\text{Compensated}} \end{array} \quad (45)$$

$$\begin{array}{ll} \mathbf{V} \text{ Comparator:} & \text{Through Current: } I_2^{\text{Compensated}} \text{ and } I_5^{\text{Compensated}} \\ & \text{Error Current: } I_2^{\text{Compensated}} + I_5^{\text{Compensated}} \end{array} \quad (46)$$

$$\begin{array}{ll} \mathbf{W} \text{ Comparator:} & \text{Through Current: } I_3^{\text{Compensated}} \text{ and } I_6^{\text{Compensated}} \\ & \text{Error Current: } I_3^{\text{Compensated}} + I_6^{\text{Compensated}} \end{array} \quad (47)$$

The comparators were named **U**, **V**, and **W** above, but be aware that this can lead to some confusion on faulted phase identification when delta connections are involved due to the associated inter-connection of phases.

Example Compensation Equations

Each transformer or CT connection has its own effect on the current that eventually makes its way to the relay. Let's look at a few examples to see how this works out.

Example 1: Dy1 Transformer

Dy1 Transformer, 115kV ($D_{1(AB)}$) / 13.8kV (Y_0);
 20MVA ($I_{\text{Full Load}} = 100\text{A @ } 115\text{kV}$ and $837\text{A @ } 13.8\text{kV}$);
 Primary CTs 200:5, Y_0 ;
 Secondary CTs 1200:5, Y_{CT6} (note the CT has been inverted).

Current @ relay, 115kV:

$$I_{UVW,115} = D_1 \times k_{\phi,115} \times \phi_{123} \quad (\text{see Eq. 17})$$

$$I_{UVW,Relay} = N_{CT,115} \times I_{UVW,115} \quad (\text{see Eq. 40})$$

The net 115kV equation is:

$$I_{UVW,Relay,115} = N_{CT,115} \times D_1 \times k_{\phi,115} \times \phi_{123} \quad (48)$$

Current @ relay, 13.8kV

$$I_{UVW,13.8} = 1 \times k_{\phi,13.8} \times \phi_{456} \quad (\text{see Eq. 10})$$

$$I_{UVW,Relay,13.8} = -1 \times N_{CT,13.8} \times I_{UVW,13.8} \quad (\text{see Eq. 41})$$

The net 13.8kV equation is:

$$I_{UVW,Relay,13.8} = -1 \times N_{CT,13.8} \times k_{\phi,13.8} \times \phi_{456} \quad (49)$$

Note that in balanced conditions $\phi_{123} + \phi_{456} = 0$, and as seen by comparing (48) and (49), what started out as a balanced condition in the transformer has become two different current values at the relay. The balanced flux has been modified by:

- Transformer Turns (part of k_{ϕ})
- Transformer winding connections
- CT ratios
- CT connections

The approach used in numeric relays is to compensate by adding multiplying factors CF_{115} and $CF_{13.8}$ to (48) to create a target multiplication factor that puts the equivalency back into the sensed current, so that the error current is 0 in the differential comparator equations (43), (44), and (45). The initial unmodified compensation equation is:

$$\left[CF_{115} \times (N_{CT,115} \times D_1 \times k_{\phi,115} \times \phi_{123}) \right] + \left[CF_{13.8} \times (-1 \times N_{CT,13.8} \times k_{\phi,13.8} \times \phi_{456}) \right] = 0 \quad (50)$$

The part in the parenthesis in (50) represents the two sets of current inputs to the relay I_{Relay} . and $CF_{\#}$ represents the math the relay needs to apply to the current to see the currents as equivalent. Let us simplify (50) by first collecting the magnitude compensation adjustments to the left. The resultant equation is:

$$\left[CF_{115} \times \left((-1 \times k_{\phi,115} \times k_{\phi,13.8}^{-1} \times N_{CT,115} \times N_{CT,13.8}^{-1}) \times (D_1 \times \phi_{123}) \right) \right] + \left[CF_{13.8} \times \phi_{456} \right] = 0 \quad (51)$$

This allows us to state CF_{115} in terms of only phase compensation adjustments and $CF_{13.8}$ in terms of magnitude and phase adjustments. In this case, CF_{115} has no phase compensation adjustments, but $CF_{13.8}$ has both magnitude and phase adjustments. To make (51) true, we need:

$$CF_{115} = 1 \quad (52)$$

$$CF_{13.8} = (-1 \times k_{\phi,115} \times k_{\phi,13.8}^{-1} \times N_{CT,115} \times N_{CT,13.8}^{-1}) \times D_1 \quad (53)$$

$CF_{13.8}$ Magnitude Compensation Factor

The magnitude effect has to account for the transformer and CT turns ratio. Recall from (1) and (2) that $k_{\phi,\#} = 1/(N_{\#}k_C)$ where $N_{\#}$ is the # of transformer coil turns, and k_C is a constant for the core design. Recall also the turns ratio calculations of (23). The overall ratio of $k_{\phi,\#}$ is:

$$k_{\phi,115} \times k_{\phi,13.8}^{-1} = \frac{N_{TURNS,13.8}}{N_{TURNS,115}} = \frac{13.8}{\sqrt{3} \cdot 115} = 0.069282 \quad (54)$$

The CT ratio factor (42) is:

$$N_{CT,115} \cdot N_{CT,13.8}^{-1} = \frac{5/200}{5/1200} = 6 \quad (55)$$

Hence, the relay multiplies the current coming into the 13.8kV side by the factor:

$$CF_{13.8, Mag} = \left[-1 \times k_{\phi,115} \times k_{\phi,13.8}^{-1} \times N_{CT,115} \times N_{CT,13.8}^{-1} \right] = \left[-1 \times 0.069282 \times 6 \right] \\ = \begin{bmatrix} -0.415692 & 0 & 0 \\ 0 & -0.415692 & 0 \\ 0 & 0 & -0.415692 \end{bmatrix} \quad (56)$$

Some may note a missing “sqrt (3)” factor in this equation that is used to reduce the magnitude of current that is seen after a delta summation. This matter will be discussed later, under “Application to Protective Relay Settings.”

Net Compensation Equations

A phase compensation factor is required when different phase transformation factors (e.g., $R_{\#}$ or $D_{\#}$) show up in the two phase compensation factors, such as was found in (52) and (53).

The compensation is on the currents making it to the relay, so let us give some names to the relay currents:

$$\begin{bmatrix} I_{1,Relay} \\ I_{2,Relay} \\ I_{3,Relay} \end{bmatrix} = \begin{bmatrix} I_{115,U,Relay} \\ I_{115,V,Relay} \\ I_{115,W,Relay} \end{bmatrix} \quad \begin{bmatrix} I_{4,Relay} \\ I_{5,Relay} \\ I_{6,Relay} \end{bmatrix} = \begin{bmatrix} I_{13.8,U,Relay} \\ I_{13.8,V,Relay} \\ I_{13.8,W,Relay} \end{bmatrix} \quad (57)$$

The 115kV phase compensation is the most basic equation possible:

$$\begin{aligned} I_{123,Relay}^{Compensated} &= CF_{115,Phase} \times I_{123,Relay} \\ I_{123,Relay}^{Compensated} &= 1 \times I_{123,Relay} \end{aligned} \quad (58)$$

$$\begin{bmatrix} I_{1,Relay}^{Compensated} \\ I_{2,Relay}^{Compensated} \\ I_{3,Relay}^{Compensated} \end{bmatrix} = \begin{bmatrix} 1 & 0 & 0 \\ 0 & 1 & 0 \\ 0 & 0 & 1 \end{bmatrix} \begin{bmatrix} I_{1,Relay} \\ I_{2,Relay} \\ I_{3,Relay} \end{bmatrix}$$

The overall (magnitude and phase) 13.8kV compensation equation is:

$$\begin{aligned} I_{456,Relay}^{Compensated} &= CF_{13.8,Mag} \times CF_{13.8,Phase} \times I_{456,Relay} \\ I_{456,Relay}^{Compensated} &= (-1 \times k_{\phi,115} \times k_{\phi,13.8}^{-1} \times N_{CT,115} \times N_{CT,13.8}^{-1}) \times D_1 \times I_{456,Relay} \end{aligned} \quad (59)$$

$$\begin{bmatrix} I_{4,Relay}^{Compensated} \\ I_{5,Relay}^{Compensated} \\ I_{6,Relay}^{Compensated} \end{bmatrix} = \begin{bmatrix} -0.415692 & 0 & 0 \\ 0 & -0.415692 & 0 \\ 0 & 0 & -0.415692 \end{bmatrix} \begin{bmatrix} 1 & -1 & 0 \\ 0 & 1 & -1 \\ -1 & 0 & 1 \end{bmatrix} \begin{bmatrix} I_{4,Relay} \\ I_{5,Relay} \\ I_{6,Relay} \end{bmatrix}$$

This in clearer terms is:

$$\begin{aligned} I_{4,Relay}^{Compensated} &= -0.415692 \cdot (I_{4,Relay} - I_{5,Relay}) \\ I_{5,Relay}^{Compensated} &= -0.415692 \cdot (I_{5,Relay} - I_{6,Relay}) \\ I_{6,Relay}^{Compensated} &= -0.415692 \cdot (I_{6,Relay} - I_{4,Relay}) \end{aligned} \quad (60)$$

The results of (58) and (60) are then fed into the comparator equations (45), (46), and (47).

Example 2 - Dz2 with Delta CT Configuration

Let us look at a more complicated application that gives a more involved application of the phase transformation factors. We will use a fairly uncommon transformer and assume someone selects fairly strange CT connections. Let's see if and how the relay could compensate.

Dz2 Transformer

115kV (D_1) / 13.8kV ($Z_{11(AC/UW)}$)

20MVA (for $I_{Full\ Load} = 100A @ 115kV$ and $837A @ 13.8kV$)

Primary CTs 200:5, Y_0 .

Secondary CTs 1200:5, D_{11}

The net 115kV equation is (Note Zigzag with Delta primary created Double Delta):

$$I_{UVW,Relay,115} = 1 \times N_{CT,115} \times D_1 \times D_1 \times k_{\phi,115} \times \Phi_{123} \quad (61)$$

The net 13.8kV equation is (Note CT is $D_{CT,11}$):

$$I_{UVW,Relay,13.8} = D_{11} \times N_{CT,13.8} \times k_{\phi,13.8} \times \Phi_{456} \quad (62)$$

The overall compensation equation is:

$$\left[CF_{115} \times (1 \times N_{CT,115} \times D_1 \times D_1 \times k_{\phi,115} \times \Phi_{123}) \right] + \left[CF_{13.8} \times (D_{11} \times N_{CT,13.8} \times k_{\phi,13.8} \times \Phi_{456}) \right] = 0 \quad (63)$$

Again, we can rearrange (63) to bring the magnitude compensation factors to one side of the equation to allow us to state CF_{115} in terms of only phase compensation adjustments, and $CF_{13.8}$ in terms of magnitude and phase adjustments.

$$\left[CF_{115} \times \left((k_{\phi,115} \times k_{\phi,13.8}^{-1} \times N_{CT,115} \times N_{CT,13.8}^{-1}) \times (D_1 \times D_1 \times \Phi_{123}) \right) \right] + \left[CF_{13.8} \times (D_{11} \times \Phi_{456}) \right] = 0 \quad (64)$$

and hence to make (64) true, we need:

$$CF_{115} = D_{11} \quad (65)$$

$$CF_{13.8} = (k_{\phi,115} \times k_{\phi,13.8}^{-1} \times N_{CT,115} \times N_{CT,13.8}^{-1}) \times (D_1 \times D_1) \quad (66)$$

The magnitude adjustment factor is nearly the same as the previous example, but the Y_6 CT connection added a negative in the previous example, and since this is a delta/zigzag winding, the k_{ϕ} is slightly different. Applying (3) and (39) we will find:

$$k_{\phi,115} \times k_{\phi,13.8}^{-1} = \frac{N_{Turns,13.8}}{N_{Turns,115}} = \frac{3 \cdot 13.8}{115} = 0.040 \quad (67)$$

and the CT ratio is 6, as it was in the previous example. The net magnitude adjustment factor is:

$$\begin{aligned} \mathbf{CF}_{13.8, \text{Mag}} &= \left[\mathbf{k}_{\phi, 115} \times \mathbf{k}_{\phi, 13.8}^{-1} \times \mathbf{N}_{\text{CT}, 115} \times \mathbf{N}_{\text{CT}, 13.8}^{-1} \right] = \left[\mathbf{0.040} \times \mathbf{6} \right] \\ &= \begin{bmatrix} 0.240 & 0 & 0 \\ 0 & 0.240 & 0 \\ 0 & 0 & 0.240 \end{bmatrix} \end{aligned} \quad (68)$$

The 115kV phase compensation equation is:

$$\begin{aligned} \mathbf{I}_{123, \text{Relay}}^{\text{Compensated}} &= \mathbf{CF}_{115, \text{Phase}} \times \mathbf{I}_{123, \text{Relay}} \\ \mathbf{I}_{123, \text{Relay}}^{\text{Compensated}} &= \mathbf{D}_{11} \times \mathbf{I}_{123, \text{Relay}} \end{aligned} \quad (69)$$

$$\begin{bmatrix} \mathbf{I}_{1, \text{Relay}}^{\text{Compensated}} \\ \mathbf{I}_{2, \text{Relay}}^{\text{Compensated}} \\ \mathbf{I}_{3, \text{Relay}}^{\text{Compensated}} \end{bmatrix} = \begin{bmatrix} 1 & 0 & -1 \\ -1 & 1 & 0 \\ 0 & -1 & 1 \end{bmatrix} \begin{bmatrix} \mathbf{I}_{1, \text{Relay}} \\ \mathbf{I}_{2, \text{Relay}} \\ \mathbf{I}_{3, \text{Relay}} \end{bmatrix}$$

This in clearer terms is:

$$\begin{aligned} \mathbf{I}_{1, \text{Relay}}^{\text{Compensated}} &= (\mathbf{I}_{1, \text{Relay}} - \mathbf{I}_{3, \text{Relay}}) \\ \mathbf{I}_{2, \text{Relay}}^{\text{Compensated}} &= (\mathbf{I}_{2, \text{Relay}} - \mathbf{I}_{1, \text{Relay}}) \\ \mathbf{I}_{3, \text{Relay}}^{\text{Compensated}} &= (\mathbf{I}_{3, \text{Relay}} - \mathbf{I}_{2, \text{Relay}}) \end{aligned} \quad (70)$$

The 13.8kV compensation equation includes a “double delta” $\mathbf{D}_1 \times \mathbf{D}_1$ factor, introduced previously (24). The net 13.8kV magnitude and phase compensation equation is:

$$\begin{aligned} \mathbf{I}_{456, \text{Relay}}^{\text{Compensated}} &= \mathbf{CF}_{13.8, \text{Mag}} \times \mathbf{CF}_{13.8, \text{Phase}} \times \mathbf{I}_{456, \text{Relay}} \\ \mathbf{I}_{456, \text{Relay}}^{\text{Compensated}} &= \left(\mathbf{k}_{\phi, 115} \times \mathbf{k}_{\phi, 13.8}^{-1} \times \mathbf{N}_{\text{CT}, 115} \times \mathbf{N}_{\text{CT}, 13.8}^{-1} \right) \times (\mathbf{D}_1 \times \mathbf{D}_1) \times \mathbf{I}_{456, \text{Relay}} \end{aligned} \quad (71)$$

$$\begin{bmatrix} \mathbf{I}_{4, \text{Relay}}^{\text{Compensated}} \\ \mathbf{I}_{5, \text{Relay}}^{\text{Compensated}} \\ \mathbf{I}_{6, \text{Relay}}^{\text{Compensated}} \end{bmatrix} = \begin{bmatrix} 0.240 & 0 & 0 \\ 0 & 0.240 & 0 \\ 0 & 0 & 0.240 \end{bmatrix} \begin{bmatrix} 1 & -2 & 1 \\ 1 & 1 & -2 \\ -2 & 1 & 1 \end{bmatrix} \begin{bmatrix} \mathbf{I}_{4, \text{Relay}} \\ \mathbf{I}_{5, \text{Relay}} \\ \mathbf{I}_{6, \text{Relay}} \end{bmatrix}$$

In clearer terms, this is:

$$\begin{aligned} \mathbf{I}_{4, \text{Relay}}^{\text{Compensated}} &= 0.240 \cdot (\mathbf{I}_{4, \text{Relay}} + \mathbf{I}_{6, \text{Relay}} - 2 \cdot \mathbf{I}_{5, \text{Relay}}) \\ \mathbf{I}_{5, \text{Relay}}^{\text{Compensated}} &= 0.240 \cdot (\mathbf{I}_{4, \text{Relay}} + \mathbf{I}_{5, \text{Relay}} - 2 \cdot \mathbf{I}_{6, \text{Relay}}) \\ \mathbf{I}_{6, \text{Relay}}^{\text{Compensated}} &= 0.240 \cdot (\mathbf{I}_{5, \text{Relay}} + \mathbf{I}_{6, \text{Relay}} - 2 \cdot \mathbf{I}_{4, \text{Relay}}) \end{aligned} \quad (72)$$

The results of (70) and (73) are then fed into the comparator equations (43), (44), and (45).

Example 3 - Dy1 but Phase Transformations Cancel Out

Assume the same system as Example 1 but let us hook the secondary CT in D_1 . The compensation equation (50) becomes:

$$\left[CF_{115} \times (N_{CT,115} \times D_1 \times k_{\phi,115} \times \phi_{123}) \right] + \left[CF_{13.8} \times (D_1 \times N_{CT,13.8} \times k_{\phi,13.8} \times \phi_{456}) \right] = 0 \quad (73)$$

The relay sees the same D_1 phase compensation on both inputs and hence the relay adds no additional phase compensation transformation to the incoming currents. It will only need to do magnitude compensation. The rest of the compensation factor analysis is approximately the same as the previous examples so will not be developed.

Application to Protective Relay Settings

A few notes on how the above material works out in a numeric current differential relay:

1) Relay Magnitude Compensation Factors.

Relays can be configured to adjust for the magnitude of currents via two methods:

a) *User selected compensation taps.* In this classical method the user takes into account the transformer ratio and CT ratio that is part of 47, as well as the normal loading that the user expects, and selects a current tap that tells the relay what constitutes balanced current magnitudes. The taps may include the $\sqrt{3}$ factor described in the previous paragraph, depending on relay settings instructions from the manufacturer.

b) *Enter Xfmr parameters and let relay decide compensation factors.* In this approach, the user enters transformer data, such as voltages, winding configuration, CT ratio, CT configuration, and full load MVA, and the relay selects the appropriate current magnitude adjustment factor. This approach is more user friendly and likely results in fewer mistakes, but there may be an argument that users should know what is going on and not let the relay do their thinking for them.

c) Some relays allow customers to use either approach a) or b) via a selection in the relay logic.

2) Additional 1/Sqrt(3) Factor in Magnitude Adjustments for Delta Configurations

When balanced three phase currents are in the transformer, one effect of a $D_{\#}$ transformation is to increase the magnitude of balanced current by $\sqrt{3}$. Some relay manufacturers include a $1/\sqrt{3}$ factor in the magnitude compensation factor to remove the current increases to balanced current flow that delta transformations cause. Including the $\sqrt{3}$ inside the relay calculations tends to make relay settings more intuitive to some end users.

3) Per-Unitizing Sensed Current

Something a bit more involved is done to current magnitudes than just multiplying the current on one input by the magnitude adjustment factor. Current on both inputs are multiplied by an appropriate number to bring the current down to a common per-unitized and normalized level, commonly referred to as “per unit of tap” (dating back to electromechanical relays). The trip decisions and instruction manuals refer to things in a per-unitized manner, so a user has to be aware of the per-unitized math that occurs inside the relay. Even beyond the per-unitization on a tap basis, in a real world protective relay, if one could monitor the internal machine coding, the relay also includes additional scaling of currents to levels that give the best use of the relay’s numerical methods and a wide range to the current levels the relay can work with accurately.

4) Configuring the Phase Compensation Equations

It can be seen that just as there are a very large number of possible ways to configure a transformer and its CTs, there is a similarly very large number of possible phase compensation equations that might be needed. However, the relay does not need to have a library in its memory bank of every possible transformer and CT configuration and the resultant phase compensation that it must apply. This paper has made some effort to show that many transformation equations can be seen as the multiplication of 2 or 3 other transformations. Hence, the relay can have a subset of possible transformation equations that can be applied as needed to create the overall compensation equation for a given application. Once these transformation equations are in the relay memory, the next issue is when and how to apply them. The response from the relay manufacturers on how the various transformations are selected and used and presented to the end user varies quite a bit.

- Some manufacturers supply a set of transformation equations and ask the user to decide how to apply them, given instructions in the manual that hopefully are sufficient. Extremely detailed analysis, such as found in this paper, is not too common though. Documentation and instruction manuals are always subject to misunderstanding, especially by engineers who have limited time to study the matter. This approach puts the user in the “think hard because there is lots of room for messing up” mode.
- Some relays, especially the basic lower budget versions each manufacturer supplies, have a reduced degree of support of all the possible transformers and CT connections. This reduces the confusion factor and makes correct setup easier for the mainstream applications, but it is done at the expense of flexibility.
- Some manufacturers make the setting a bit more user friendly by listing the phase compensation equations that should be used for a given transformer configuration and phase shift. They appear to say that if you know phase shift and a few other items on the transformer, these are the equations you want to use. Without a detailed analysis of where the equations come from a user might be confused and still make a selection error.
- Some relay manufacturers attempt to remove the chance of user error by having the user state the specific transformer and CT configurations. It becomes the task of the relay internal coding to decide which phase compensation equations are proper for the configuration that was entered. This approach takes the previous bullet one step farther from a good understanding of what is being calculated by the relay, so has its drawbacks too. Hopefully this paper supplies the needed information so that a user can reason through what is going on inside the relay.

Conclusion/Summary

Hopefully the reader has learned from the above material, 1) how the myriad of “round the clock” power transformers are internally configured, as well as some understanding of the nomenclature and figures that are used, 2) the various ways delta and zigzag transformers can be configured, 3) the ways that the myriad of possible transformer and CTs connections affect the current seen by a transformer differential relay, and 4) how a transformer differential relay can numerically compensate for the differences in any transformer configuration to still determine balanced current conditions.

Author Biographies

Larry Lawhead received a BS degree in Engineering from Duke University in 1982. He worked at Potomac Electric Power Company in the Substation Test and System Protection groups until joining Basler Electric in 1989. Mr. Lawhead has held a variety of Sales and Marketing positions

with Basler and is currently Principal Application Engineer, based at Basler's Highland, Illinois, headquarters. Mr. Lawhead is a member of the IEEE-PES and is active on several working groups of the Power Systems Relay Committee.

Randy Hamilton is a Principal Electrical Design Engineer for Basler Electric Company. He has worked for Basler for more than 25 years, with experience in test and design in the areas of magnetic transformers, power supplies, voltage regulators, and, for the last ten years, protective relays. Randy graduated Magna Cum Laude from Southern Illinois University.

John Horak received his BSEE degree from the University of Houston in 1988 and his MSEE degree, specializing in power system analysis, from the University of Colorado, Denver, in 1995. John joined Basler Electric in 1997 and is a Senior Application Engineer. Previous work included ten years with Stone and Webster Engineering where he was on assignment for six years in the System Protection Engineering offices of Public Service Company of Colorado. His work has included fault calculations, relay coordination settings, control design, and equipment troubleshooting. Other previous employers include Houston Lighting and Power and Chevron. He has authored, coauthored, and presented technical papers at a variety of industry events and conferences. John is a member of IEEE-IAS and -PES and has P.E. license in Colorado.

References

- 1) ANSI/IEEE C57.12.00 IEEE Standard General Requirements for Liquid Immersed Distribution, Power, and Regulating Transformers
- 2) IEEE C57.12.70 IEEE Standard Terminal Markings and Connections for Distribution and Power Transformers
- 3) IEC 60076-1 Power Transformers – Part 1: General
- 4) J&P Transformer Book, A.C. Franklin, D.P. Franklin (12th Edition, 1998, changes author to Martin Heathcote); Butterworth-Heinemann Division, Reed Educational and Professional Publishing Ltd.

If you have any questions or need
additional information, please contact

Basler Electric Company

Route 143, Box 269, Highland, Illinois U.S.A. 62249

Tel +1 618.654.2341 Fax +1 618.654.2351

e-mail: info@basler.com

PA.E. Les Pins, 67319 Wasselonne Cedex FRANCE
Tel + 33 3.88.87.1010 Fax + 33 3.88.87.0808
e-mail: franceinfo@basler.com

No. 59 Heshun Road Loufeng District (N),
Suzhou Industrial Park, 215122, Suzhou, P.R.China
Tel +86(0)512 8227 2888 Fax +86(0)512 8227 2887
e-mail: chinainfo@basler.com

55 Ubi Avenue 1 #03-05 Singapore 408935
Tel + 65 68.44.6445 Fax + 65 65.68.44.8902
e-mail: singaporeinfo@basler.com