



Installation Instructions

Vibration Dampers 1700, 1700AA Series

GENERAL INFORMATION

AFL vibration dampers are produced with carefully designed and controlled surface finishes for High Voltage use. To maintain this quality, the dampers should be protected, preferably in their shipping containers, from dirt and foreign material prior to installation. Handling in the field should be with care to avoid mechanical damage. AFL Vibration dampers may be installed without disassembly of the clamp parts.

VIBREC® DAMPER RECOMMENDATION PROGRAM

The Vibrec damper recommendation program assists in damper requirements for transmission and distribution lines. For more information contact the AFL Technical Support Team at 1.800.866.7385.

INSTALLATION PROCEDURE

- Step 1:
- Obtain the damper spacing from AFL.
 - At the tangent tower, the centerline of the damper should be the specified distance from the center of the suspension clamp.
 - At the dead end location, the centerline of the damper should be the specified distance from the mouth of the dead end. Normally, for a phase conductor, a second damper is required at the dead end location; on a static wire, a second damper is usually not required at the dead end location. The centerline distance between the two dampers should be as specified.

*****Note: For the 1700AA series dampers, the damper is approved to be installed with either the large weight toward the structure or the small weight toward the structure.*****

- Step 2: Loosen the bolt so that the clamp may be opened sufficiently to permit cable entry into the clamp groove.

Note: The bolt need not be removed.

- Step 3: Hang the damper on the conductor at the proper spacing specified in Step 1 and tighten the bolt finger tight.

- Step 4: Tighten the bolt with a torque wrench to the recommended value for the bolt size in the table below. If the bolt has a breakaway outer head, tighten the bolt until the breakaway head shears off.

CLAMP ASSEMBLY NUMBER	BOLT DIAMETER INCH	TORQUE LBF. FT (N.M)
2 thru 6	7/16	20 (27)
7 thru 11	1/2	25 (34)
13 thru 20	5/8	40 (54)
21 thru 23	3/4	60 (81)

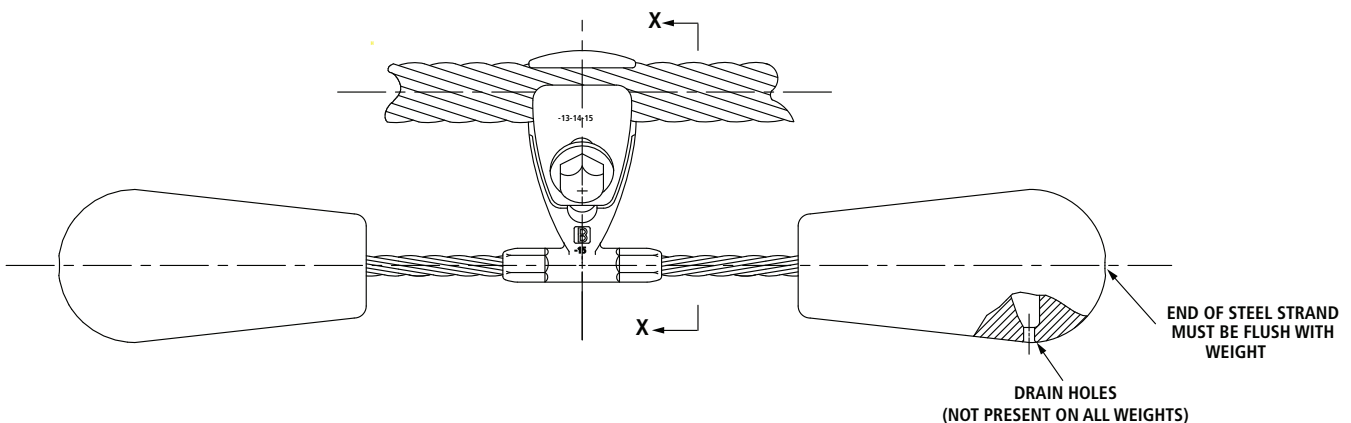
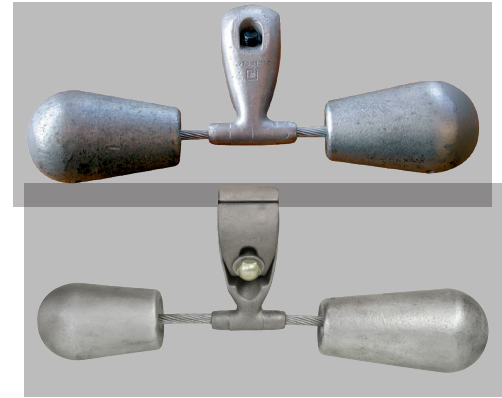

Installation Instructions (cont.)

Vibration Dampers 1700,1700AA Series

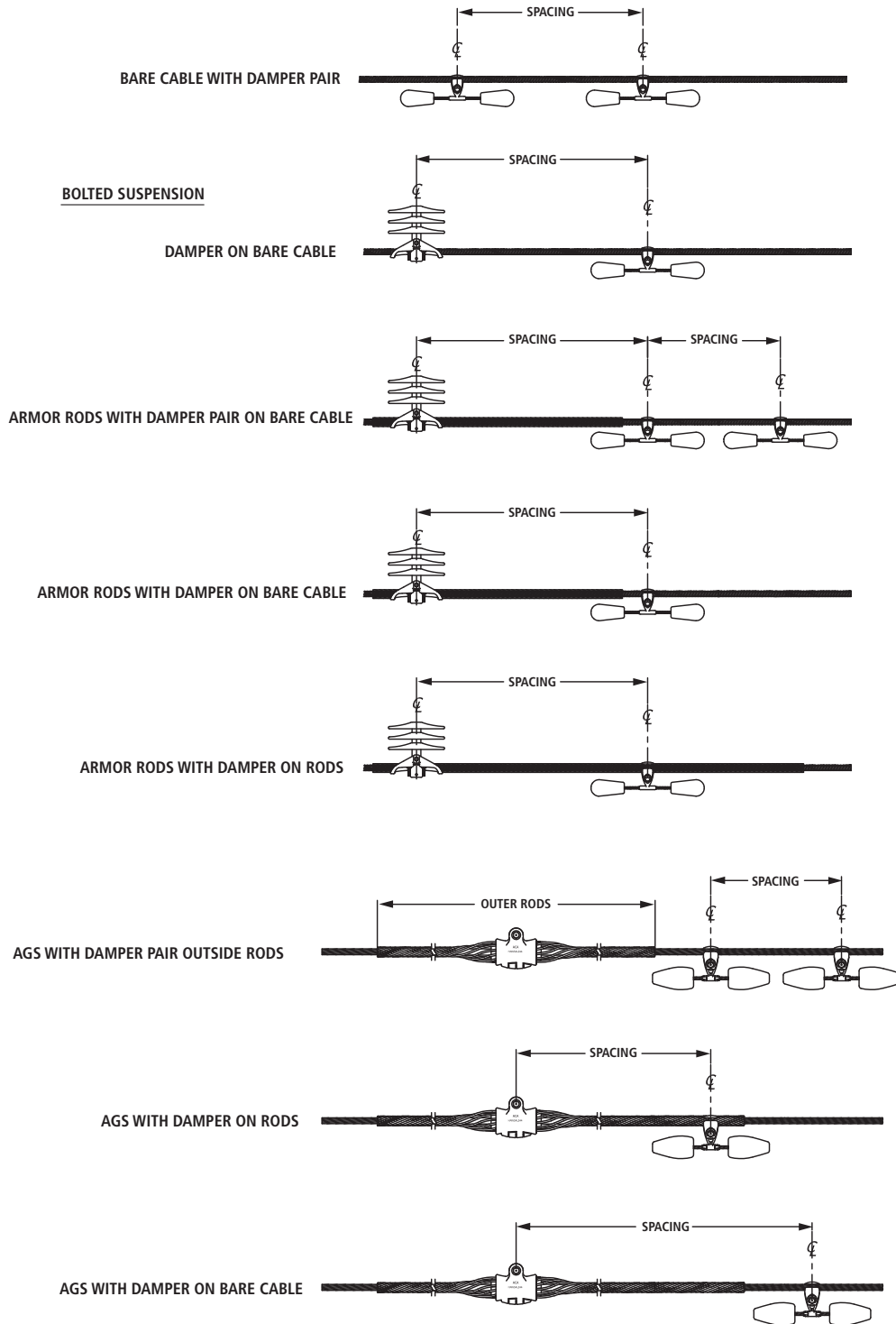

Installation Instructions (cont.)

Vibration Dampers 1700,1700AA Series

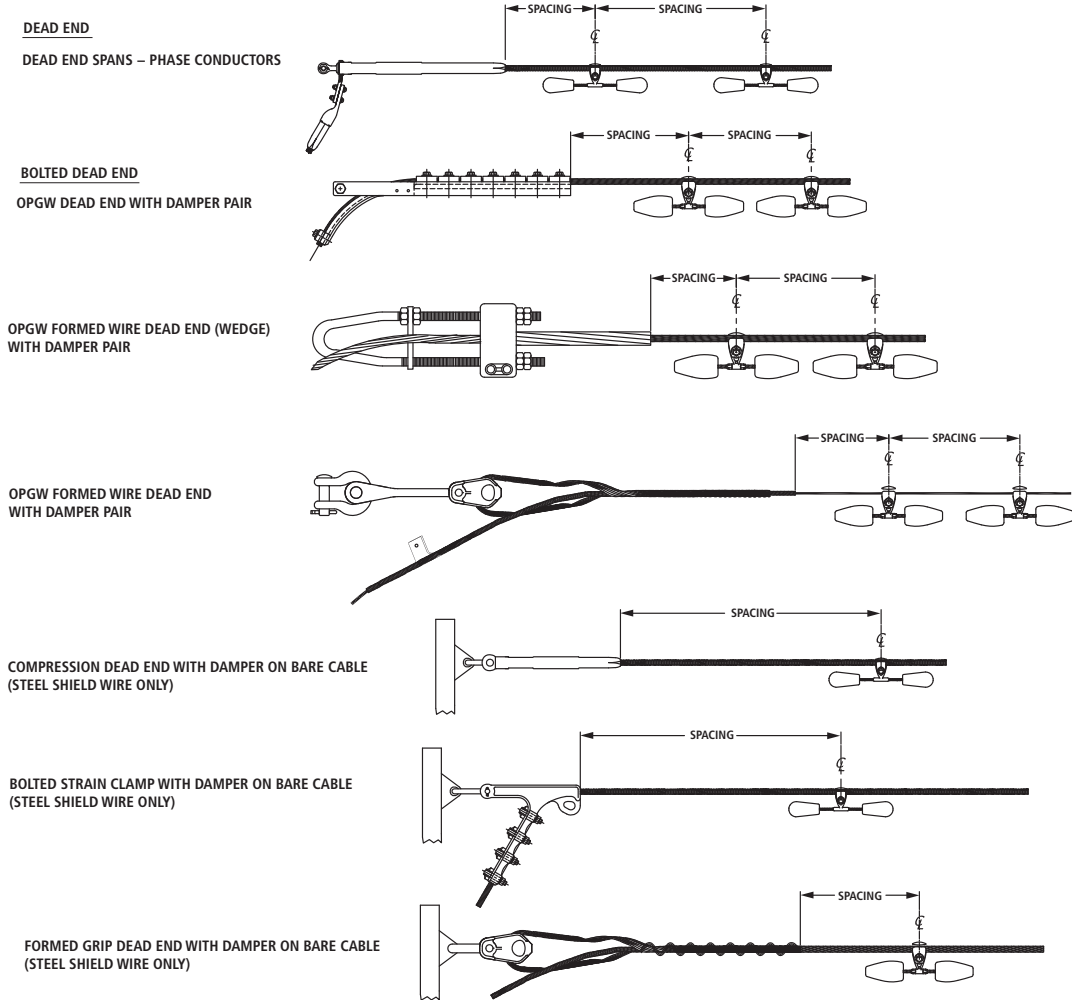

Installation Instructions (cont.)

Vibration Dampers 1700,1700AA Series

VIBRATION PROTECTION RECOMMENDATIONS – SPACING NOTES

Notes:

- Tangent Spans – Phase Conductor and Overhead Ground Wire (OHGW)
"Level One Damping" means one damper placement per conductor at one end of the span only. "Two dampers per conductor" means two damper placements (one damper placement at each end of the span).
- Tangent Spans – Dead End at One End – Phase Conductor
In spans dead ended at one end only, and requiring only one damper per conductor, the damper should be placed at the tangent structure, spaced in accordance with Dimension A or B. If the span requires three dampers per conductor, then one damper should be placed at the tangent structure, spaced in accordance with Dimension A or B, and two dampers should be placed at the deadended structure, spaced in accordance with Dimensions C and D. Normally, two dampers are recommended at conductor dead ends with insulator strings, as it is impossible to accurately predict the location of vibration node points relative to the conductor dead end. With just one damper at a dead end, the damper could, under certain wind conditions, be at a node point. The effectiveness of two dampers, spaced as recommended, assures that at least one of the two dampers will be effective at all times.
- Tangent Spans – Dead Ended at One End – Overhead Ground Wire
In spans deadended at one end only, and requiring only one damper per wire, the damper should be placed at the tangent structure, spaced in accordance with Dimension A or B. If the span requires two dampers per wire, then one damper should be placed at the tangent structure, in accordance with Dimension A or B, and one damper should be placed at the dead end, spaced in accordance with Dimension C.
- Spans Dead Ended at Both Ends – Phase Conductor
"Two dampers per conductor" means two dampers at one end of the span only, spaced in accordance with Dimensions C and D. "Four dampers per conductor" means two dampers at each end of the span, spaced in accordance with Dimensions C and D. Normally, two dampers are recommended at conductor dead ends with insulator strings, as it is impossible to accurately predict the location of vibration node points relative to the conductor dead end. With just one damper at a dead end, the damper could, under certain wind conditions, be at a node point. The effectiveness of a damper on a node is significantly reduced. The use of two dampers, spaced as recommended, assures that at least one of the two dampers will be effective at all times.
- Spans Dead Ended at Both Ends – Overhead Ground Wire
"One damper per conductor" means one damper at one end of the span, spaced in accordance with Dimension C. "Two dampers per conductor" means one damper located at each end of the span, spaced in accordance with Dimension C.
- Spans Dead Ended at Both Ends, or Tangent Spans of Dead Ended at One End, For OHGW Utilizing a Formed Guy Grip Dead End
We do not recommend the installation of damper clamps over formed-guy-grip type dead ends. Therefore, where vibration protection is required for spans using the formed type dead ends, two dampers will be required at each dead end location, with the first damper spaced at the end of the rods and the second damper located in accordance with Dimension D.
- Dampers Over Armor Rods
Dampers with the clamps placed over armor rods are not as effective as dampers with the clamp placed directly on the conductor. Therefore, if armor rods are used, the rods should be short enough as to permit installation of the damper clamp over the bare conductor, using the recommended Dimension B spacing. The Dimension B is used whenever armor rods, line guards or AGS units are specified. In the event the rod lengths are too long to permit installation directly on the conductor, the damper clamp must be selected to fit over the installed rods.
- Selective Damping
The ability of a damper to protect a given span may be hindered by vibration in adjacent undamped spans even though the vibration in the undamped spans is not at a damaging level for the undamped span. Therefore, damping of adjacent spans is suggested at times. For simplicity, the Vibrec® program recommends that spans adjacent to a span requiring dampers also be damped. AFL will, however, approve omission of dampers in spans shorter than the level zero limit when the adjacent damped spans are less than 50% of the one-damper limit.
- If there are any questions with respect to the damper recommendations or placement, contact your local representative.