

Disclaimer: The contents of this guidance document does not have the force and effect of law and is not meant to bind the public in any way. This document is intended only to provide clarity to the public regarding existing requirements under the law or agency policies.

<http://waterheatertimer.org/Names-of-parts-on-electric-pole.html>

UNITED STATES DEPARTMENT OF AGRICULTURE
Rural Utilities Service

BULLETIN 1724D-112

RD-GD-2018-92

SUBJECT: The Application of Capacitors on Rural Electric Systems

TO: RUS Electric Borrowers and RUS Electric Staff

EFFECTIVE DATE: Date of Approval

OFFICE OF PRIMARY INTEREST: Electric Staff Division

INSTRUCTIONS: Replaces Bulletin 1724D-112, dated April 27, 2001

AVAILABILITY: This bulletin is available on the Rural Utilities Service website at www.usda.gov/rus/electric.

PURPOSE: To provide Rural Utilities Service (RUS) borrowers and others guidance on the use, characteristics, and benefits of power factor correction capacitors on rural distribution systems.

As a rural power distribution system load grows, the system power factor usually declines. This gradual load growth and decrease in power factor increases system energy losses, lowers voltages at consumers' premises, degrades the performance of energy utilization equipment, and drives up the cost per unit of energy delivered. For optimum performance and avoidance of these most undesirable conditions, especially in today's competitive electric industry, prudent utility providers should make every effort to maintain power factor as close to 1.0 as economically practical.

To gain optimum performance and advantage, power factor correction capacitors need to be efficiently and effectively sized, located, and utilized on power circuits at times appropriate to the system's load cycle. This bulletin presents guidance information on all these considerations.



Christopher A. McLean
Assistant Administrator
Electric Program

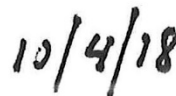

Date

TABLE OF CONTENTS

1	Introduction.....	4
2	How Capacitors Work.....	8
3	Capacitor Concerns.....	23
4	Capacitor Sizing, Location, and Use.....	40
5	Power Supply Considerations.....	53
6	Capacitors for Induction Motors.....	55
7	References.....	60

Appendices

Appendix A: Power Factor Table

Appendix B: Capacitor Rating Table for Motors

INDEX:

Capacitors
Distribution System Planning
Power Factor

ABBREVIATIONS

Ω	Ohms, symbol for the unit of electrical resistance
ACSR	Aluminum Cable, Steel-Reinforced
ARC COS	Trigonometric Inverse Cosine
ARC TAN	Trigonometric Inverse Tangent
COS	Trigonometric Cosine
CT	Current Transformer
CVR	Conservation Voltage Reduction
EEl	Edison Electric Institute
EPA	U.S. Environmental Protection Agency
Hz	Hertz (cycles per second)
I	Current
IEEE	Institute of Electrical and Electronics Engineers
+j	J Operator, followed by the impedance value, indicates that the voltage across an inductor leads the current through it by 90°
kcmil	1,000 Circular Mils
kV	Kilovolt (1,000 volts)
kVA	Kilovolt-Amperes
kVAr	Kilovolt-Amperes Reactive
kVArh	Kilovolt-Amperes Reactive-Hours
kW	Kilowatts
kWh	Kilowatt-Hours
LTC	Load Tap Changing
MOV	Metal-Oxide Varistor

NEMA	National Electrical Manufacturers Association
NRECA	National Rural Electric Cooperative Association
OCR	Oil Circuit Recloser
PCB	Polychlorinated Biphenyls
p.f.	Power Factor
PLC	Programmable Logic Controllers
pu	Per Unit
rms	Root Mean Square
RUS	Rural Utilities Service
SCADA	System Control and Data Acquisition
TVSS	Transient Voltage Surge Suppression
V	Volt
V.D.	Voltage Drop
VAr	Volt-Amperes Reactive

ACKNOWLEDGMENTS

This version of Bulletin 1724D-112 was updated by the Power Quality Subcommittee of the National Rural Electric Cooperative Association in 2016. Members of the subcommittee who contributed to this revision include:

Ed Bevers, Rural Electric Cooperative, Inc., Lindsay, Okla.
Scott Blecke, Great Lakes Energy, Boyne City, Mich.
Jeff Coleman, Berkeley Electric Cooperative, Moncks Corner, S.C.
Herman Dyal, Clay Electric Cooperative, Inc., Keystone Heights, Fla. (retired)
Varzavand Irani, Nueces Electric Cooperative, Inc., Corpus Christie, Texas
Ted Pejman, Rural Utilities Service, U.S.D.A. (retired)
Tony Thomas, National Rural Electric Cooperative Association, Arlington, Va.
Jeffrey Triplett, Power System Engineering, Inc., Marietta, Ohio
Lewis Shaw, Brunswick Electric Membership Corporation, Shallotte, N.C.

1 INTRODUCTION

a. Why Power Factor Correction?

The expansion of power systems for farm electrification and the growth of motor and other inductive loads for home and farm uses causes a decline in system power factor. This downward trend in power factor leads to:

1. Voltage regulation problems,
2. Increased system losses,
3. Power factor penalties in wholesale power contracts, and
4. Reduced system capacity.

Any of these four deficiencies are, in themselves, intolerable for today's prudent utility operator. Utilities, under consumer and regulator scrutiny, have to design, construct, operate, and maintain the most reliable, efficient, and economical facilities possible.

Capacitors offer a means of improving system power factor and the above conditions by reducing the reactive kilovar load carried by the utility system.

b. Voltage Regulation

One of the greatest advantages gained by the proper size and location of distribution capacitors is voltage improvement. By placing leading Volt-Amperes Reactive (VAr) loads near lagging VAr load centers, the lagging VAr on a system basis are cancelled with an associated increase in voltage and gain in system capacity.

Care is required not to exceed the lagging VAr requirement at any time. Capacitors should be sized for peak load requirements and removed from the system as the load drops, usually through switched controls. Capacitors draw a specific leading current that generates a voltage rise through the reactive ohms of the system impedance (see Section 2f of this bulletin for these calculations).

Today utility systems are increasingly implementing voltage regulation programs to reduce system demand on peak as well as reduce system losses both on and off peak. These programs are referred to as Conservation Voltage Reduction (CVR). This program will be discussed further in Section 2f (2) of this bulletin.

(1) Capacitors or Voltage Regulators

Care should be taken in choosing between capacitors and voltage regulators for voltage improvement. Often, both are necessary to have a well-balanced system operating at maximum efficiency. Shunt capacitors provide some voltage rise and can do so at a lower cost than a line regulator. Sample calculations are shown in the following sections.

However, for some load conditions, the voltage rise offered by capacitors may be excessive and cause problems for customers' connected equipment. Higher cost regulators offer a means for maintaining more constant system voltage. The combination of regulators and capacitors provides the best of both worlds.

A 600 Kilovolt-Amperes Reactive (kVAr) capacitor bank—including labor and a control—will cost approximately \$10,000 and can provide about a 4-volt rise (more or less, depending on where the capacitors are located) when connected on a distribution feeder. That rise is either on or off, depending on whether the capacitor is on-line or off. This capacitance provides power factor correction by canceling the effects of 600 kVAr of lagging reactive load.

A single-phase line regulator, at about \$13,600, can provide sixteen $\frac{3}{4}$ -volt ($\frac{5}{8}\%$) steps up or down (on a 120-volt base), depending on whether the regulator is raising or lowering the voltage. Although this step range approximates a 12-volt boost or buck capacity, Rural Utility Service (RUS) suggests that effective voltage analysis has shown that the system operator should allow only an 8-volt variation per regulator.

Moreover, from voltage analysis results, the use of only two series regulators are recommended in addition to the substation regulator or Load Tap Changing (LTC) transformer. If more than two series regulators are boosting and there is a fault near the end of the line when an Oil Circuit Recloser (OCR) opens, the line voltage can go up too high and damage customer-owned equipment. This means that, if any line regulator needs to raise to step 11 or greater, the incoming voltage serving the last consumer prior to the regulator is below 118 volts, which is outside the Class A voltage limits that RUS recommends be observed as a design criteria.

Voltage improvement can be gained fairly inexpensively with capacitors, relative to voltage regulators at \$40,600 for a 3-phase bank. But this gain may be at the cost of higher losses and power factor penalty charges when the excess capacitors needed for voltage improvement are allowed to drive the power factor leading.

In general, voltage regulators should be used to maintain accurate control of voltage throughout the load cycle (control voltage fluctuation), and shunt capacitors should be used to correct low power factors.

c. Increased System Losses

A distribution utility system serves connected loads that require both reactive energy as well as real energy. Both of these energy types must be served by the power supplier's generator. This relationship is discussed in greater detail in

[Section 2a](#) of this bulletin. In simple terms, the higher the power factor up to unity at the delivery point, the lower the reactive energy being served from the power supplier and the more real energy can be delivered to the load. The addition of capacitors on the distribution line reduces the reactive energy flow and current, thereby reducing losses.

Distribution capacitors can reduce system line losses, as long as the system power factor is not forced into a leading mode. Line losses at 80% leading power factor are just as detrimental as line losses at 80% lagging power factor. Properly placed and sized capacitors can usually reduce system line losses sufficiently to justify the cost of their installation.

If switched capacitors are used to regulate voltage, the system operator will need to conduct frequent system studies to monitor the load growth and know when capacitors should be switched on and off. Studies are especially important where loading is not uniform along the feeder. It is important to remember that costs to switch capacitor banks add \$2,000 to \$5,000 per bank, depending upon the control type used.

The energy loss in an older style standard paper-type capacitor is small (not exceeding 3.3 watts per kVAr at rated voltage and frequency). Expressed in terms of efficiency, this is 99.67%. However, new film-type capacitors available today have energy losses below one watt per kVAr, which results in 99.9% efficiency. In addition, the size and weight of newer capacitors have been greatly reduced by use of film in lieu of Kraft paper as the dielectric material.

Capacitors energized at rated voltage always operate at full load. Therefore, system load cycles have no effect on the losses of capacitors operating at rated voltage. Operating capacitors at voltages above their rated values can diminish capacitor life spans. Operation at voltages below their rated value reduces the effective (kVAr) size of the capacitor with a resulting decrease in their benefits.

d. Power Factor Penalty Charges

Power Factor correction may be initiated to reduce power factor penalty charges in purchased power. Most power purchase rates have penalties for poor power factor. That penalty takes several forms, but the most common is an adjustment in Billing Demand rate. The Measured Demand is increased by the ratio of the contract minimum power factor over the actual metered power factor and is calculated as follows:

$$\text{Billing Demand} = \text{Metered Peak Demand} \times \frac{\text{Contract Power Factor}}{\text{Measured Power Factor}}$$

Equation 1: Billing Demand

Power Factor is either measured during the system peak or is calculated as an average power factor for the month as follows:

$$\text{p.f.} = \text{COS} \left[\text{ARC TAN} \left(\frac{\text{kVAr} \times \text{Hours}}{\text{kWh}} \right) \right]$$

Equation 2: Power Factor

In some cases, billing departments may only have kilowatts (kWh) and kilovolt-amperes reactive-hours (kVArh) data from which to calculate power factor. Equation 2 is the inverse of the true power factor formula. However, Table A1 in Appendix A, which has been in use for years, corrects the calculation by having values greater than unity.

- (1) EXAMPLE 1. Find the Power Factor for 244,300 kWh and 200,700 kVArh (Reactive) meter readings.

SOLUTION: $\text{kVArh} \div \text{kWh} = 200,700 \div 244,300 = 0.82153$. Using the Power Factor Table (Table A1 of Appendix A), we find 0.82153 is closest value in the table to 0.821. This value corresponds to value of 0.773 for the power factor in Table A1. (This power factor is obtained by reading the value (0.77) in the left-most cell in the same row as the 0.821 value 0.821 ratio. Then add to the 0.77 the value (0.003) in the top-most cell in the same column as the 0.821 ratio.)

So the Power Factor is 0.773.

ALTERNATIVE SOLUTION: Using Equation 2 from above directly:

$$\text{p.f.} = \text{COS} \left[\text{ARC TAN} \left(\frac{\text{kVAr} \times \text{Hours}}{\text{kWh}} \right) \right]$$

$$\text{p.f.} = \text{COS} \left[\text{ARC TAN} \left(\frac{200,700}{244,300} \right) \right]$$

$$\text{p.f.} = \text{COS} [\text{ARC TAN} (0.82153)]$$

$$\text{p.f.} = \text{COS} [39.4^\circ] = 0.773$$

In summary, low system power factor results in higher demand charges. With demand charges of \$6 to \$12 per kilowatt (kW) and full annual ratchet, a 1-kW increase costs from \$72 to \$144 per year. The cost of poor power factor is then very tangible, but the true costs of poor power factor

should also include increased losses, poor voltage, and wasted system capacity.

e. Reduced System Capacity

For the reasons discussed in Section 1c of this bulletin, the cause of increased system losses on the distribution system similarly affect the subtransmission and bulk transmission system providing power to the distribution plant. These bulk power facilities also have to provide capacity to satisfy the inductive kVAr load installed on the distribution system. The resultant reactive current flow produces losses on the bulk facilities as well, introducing unnecessary costs. Generators too have to provide the reactive needs of distribution plant inductive loads making generators less efficient as well.

As will be seen, capacitors will provide improvement on the bulk facilities as a by-product of the improvements they bring about on the distribution feeder.

2 HOW CAPACITORS WORK

a. What is Power Factor?

This section explains the power relationships between watts, Volt-Amperes Reactive (Var), volt-amperes, and power factor. The total power (Apparent Power) in Kilovolt-Amperes (kVA) delivered by a distribution line to a load consists of two parts, Real Power (kW) and Reactive Power (kVAr), as shown in the container analogy of Figure 1.

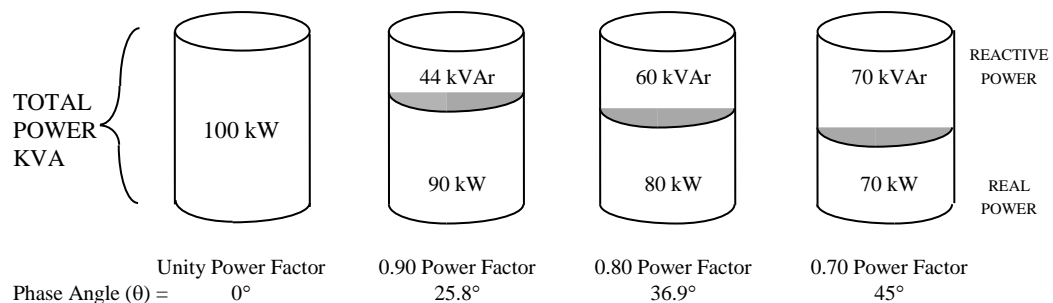

100 kVA loads at various power factors. kW is usable power. Excessive kVAr is wasted power. As power factor increases, the useful power delivered is increased. As can be seen, lagging kilovars form an appreciable component of the system load.

Figure 1: Real and Reactive Power Analogy

In the Figure 1 analogy, electricity required to serve a system is represented as a mug of root beer where you have to purchase a whole mug to get what you really want. Liquid root beer represents kW energy which can perform useful work. One would prefer a mug full of liquid root beer with little foam. The reactive part

(or the foam in this analogy) of the total kVA, while it performs no useful work, has to be purchased, in the absence of power factor correction. Reactive energy has to be purchased because connected loads and associated conductors are demanding this type of energy. As a result, reactive energy has to be supplied by the generator at the power plant, be transformed and transmitted along the transmission grid, and finally be transformed again on the distribution system for delivery to the reactive load that requires it.

If the reactive part of the total kVA needed to serve a distribution system is to be produced by the power supplier's generator, then the reactive component travels through the entire power delivery system. If the distribution system's reactive load can be canceled by a capacitor placed at the reactive load center, the entire power delivery system will be relieved of this kVAr burden and, thereby, gains capacity. If a capacitor is connected to the distribution system either ahead of or beyond the system's load center, the capacitor still provides reactive loading relief, but the system will not gain the full advantages of voltage and loss improvement which would be afforded by proper capacitor placement.

Figure 1 depicts an analogy of the relationship between kVA, kW, kVAr, and p.f.. The real power component in kW, which is capable of doing work, is what utilities sell, and it is measured using kWh meters. The inductive reactive power component, measured in lagging kVAr, is required by and supplied to motors to magnetize motor-winding fields, transformers to magnetize transformer windings and cores, and phase conductors to sustain the magnetic fluxes associated with current flowing in the conductors.¹ This reactive lagging power component (kVAr):

1. Performs none of the useful work,
2. Is not measured on kWh meters, and
3. Has to be furnished to the loads.

The leading current developed by capacitors can effectively cancel the lagging current demanded by the reactive load components. The total power delivered to the load then consists of a real and a reactive component. Total power is measured in kVA. Power factor is defined as the ratio of real power (kW) to total power (kVA).

b. Power and Power Factor Relationships

¹ Because inductive reactances associated with circuit phase conductors decrease as the spacing between conductors decreases, conductors on narrow profile line construction should contribute less inductive reactance than conductors on standard line construction. Assuming all other circuit inductive reactance contributors are the same, required power factor correction on narrow profile lines may be less than standard line construction. This narrow profile benefit, however, may not be significant enough to justify the associated cost of additional poles, shorter spans, and the reduced basic insulation impulse level and possibility of impaired reliability and outages.

A more useful way to show the power relationships is with the Power Triangle of Figure 2. Total Apparent Power (in volt-amperes or VA or kVA) is the vector sum (not arithmetic sum) of the Real Power (in watts or kilowatts) and the Reactive Power (in VAR or kilovars). A vector has a length, or magnitude, and a direction. A vector diagram allows easy calculation of relationships within the Power Triangle using trigonometry. VAR means volt-ampere reactive, or more simply Volts times Amps ($V \times A$ or VA) shown in the reactive relationship (90 degrees out of phase with the voltage and kW). Therefore, VAR lead or lag by 90 degrees the Real Power (kW) vector. The Real Power vector always lies along and is in phase with the voltage vector. The Apparent Power vector always lies along and is in phase with the Current (Amperes) vector. Thus, simple trigonometry explains the Power Triangle of Figure 2.

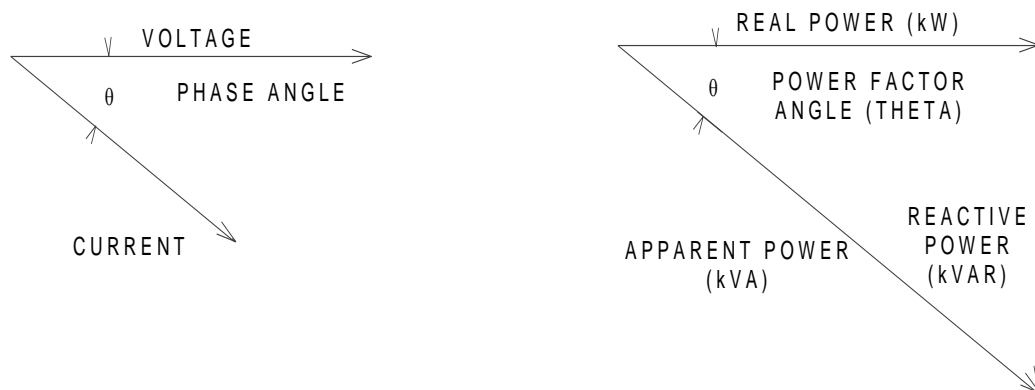

Power Triangle = A vector representation of time relationships where:

- Apparent Power (kVA) is the vector sum of Real Power (kW) and Reactive Power (kVAR)
- Real Power (kW) is in phase with the voltage vector
- Apparent Power (kVA) is in phase with the current vector
- Reactive Power is perpendicular to Real Power
- Lagging Reactive Power is customarily shown pointing Down
- Leading Reactive Power is customarily shown pointing Up

Figure 2: Power Triangle

As defined, Power Factor equals kW divided by kVA. Power factor is also equal to the Cosine of the Phase Angle (theta) between the voltage and current vectors. Power Factor is the trigonometric Cosine of the angle between the Real and Apparent Power. This angle is identical to the angle between the voltage and current vectors.

In trigonometric terms: $\text{PHASE ANGLE} = \text{ARC COS} (\text{kW} \div \text{kVA})$

Explained another way, the phase angle is equal to the angle whose Cosine is $\text{kW} \div \text{kVA}$. On scientific calculators, the ARC COS is shown as COSINE^{-1} or INVERSE COSINE.

c. Power Factor Effects

A capacitor is a leading reactive power load whose leading VAR requirements cancel an equal portion of the system's lagging VAR requirements, thereby reducing the load on the system. The leading current required by the capacitor, which flows through the lagging impedance of the system conductors and transformers, causes a voltage rise whose magnitude can be calculated.

By the addition of capacitors at a load center, the resulting decrease in VAR required of the generator actually lowers the kVA supplied by the generator at the power plant to a more pure kW load. This brings about lower losses in the system and better voltage at the load due to the resulting lower line currents. In many cases, the system can then deliver more useful power with the same investment in equipment. This provides better utilization of existing investment in equipment and may make possible the deferral of costly system improvements. This is highly desirable as electric utilities move into the era of open competition and control of wheeling costs.

A complete understanding of capacitors and their effects on the power system begins with understanding that capacitors are an unusual load with unusual characteristics. Capacitors draw current that is advanced 90 degrees (or 1/240th of a second) ahead in time of the applied voltage wave. This leading current accomplishes several worthwhile purposes if applied with understanding and in moderation. The main benefits are that the leading current cancels lagging current, which decreases kVAR losses and the voltage drop. Thus, capacitors actually cause a system voltage rise.

To see how a capacitor affects a power system, look first at the sine-wave-shaped instantaneous voltage wave generated by a rotating generator. Applied to a purely resistive load, the current wave is "in-phase" with the voltage wave as shown in Figure 3.

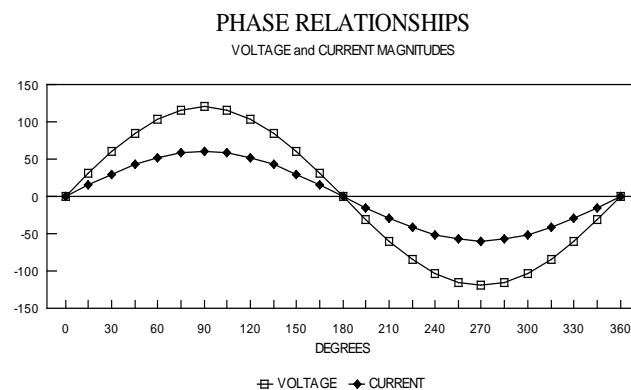
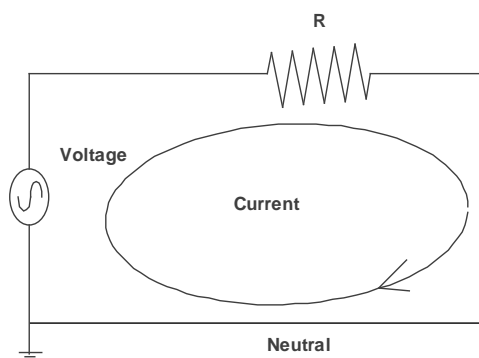

Figure 3: Current in Phase with Voltage

“In phase” means that the current wave starts “positive” at exactly the same time as does the voltage wave. The current wave also crosses the zero-amplitude axis going the same direction (positive or negative) at exactly the same time as the voltage wave and this action repeats itself at all zero-amplitude crossings. The current wave is usually not the same magnitude (height at peak) as the voltage wave but it does have the same frequency. The current magnitude is determined by the load using Ohm’s Law, which, for resistive loads, follows the rise and fall of the voltage wave exactly, and so current is called “in-phase” with the voltage.

Inductive loads, such as motors, cause the current wave to “slow down” with respect to the voltage wave as shown in Figure 4. The degree of slowness in time is measured as an electrical phase angle difference (assuming 360 degrees for one cycle) between the voltage and current waves. The frequency of power systems in the United States is 60 hertz (60 cycles per second), so one cycle represents 1/60th of a second. The voltage wave makes one complete revolution, completing both a positive and negative cycle, during a period of time that is also defined as 360 electrical degrees. So ½ cycle, or the positive (or negative) half cycle for instance, takes 180 degrees. The time to rise from zero to a peak value is ¼ cycle or 90 degrees.

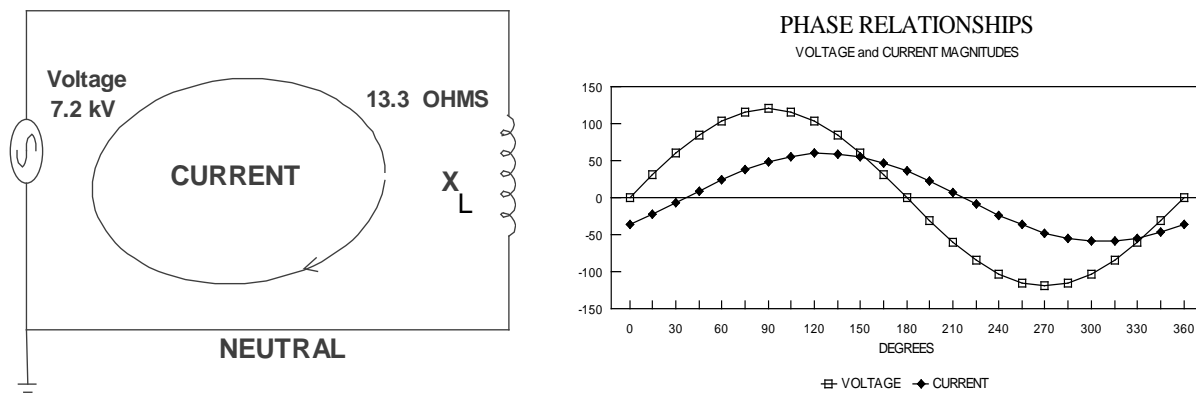

Figure 4: Current Lags the Voltage

The time to fall back to zero is another ¼ cycle or a second 90 degrees. By describing time in terms of degrees, simple trigonometry can be used to solve relationships between the sinusoidal waves.

Likewise, capacitive loads cause the current wave to “get ahead” of or “lead” the voltage wave in time as shown in Figure 5. A pure capacitor with no resistance will cause the current wave to lead the voltage wave by exactly 90 degrees. A pure inductance with no resistance will cause the current wave to lag the voltage

wave by exactly 90 degrees. But in actuality, inductors have some resistance and a small amount of capacitance. Capacitors also have some resistance and a small amount of inductance. So a full 90 degrees of lead or lag never is actually achieved.

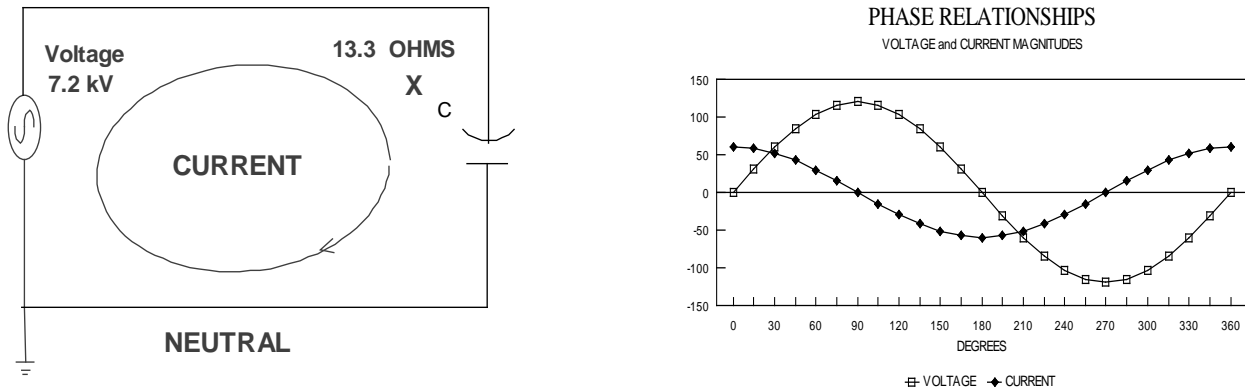

Figure 5: Current Leads the Voltage

Our goal on the power system is to cancel out as much of the effects of the line inductance and capacitance as possible to allow the most efficient power transfer from the source to the load. Motor loads and system conductors and service drop wires are inductive, causing the current to “slow down” in time and lag the voltage waves by 30–40 degrees.

Lead-lag phase angle can also be expressed by the system power factor. From the previous section, power factor has also been defined as the cosine of the phase angle between the voltage and current waves.

- (1) **EXAMPLE 2.** For an inductive phase angle of 30 degrees, the power factor equals cosine (30 degrees) or 0.866 lagging (meaning inductive). This can be further expressed as power factor of 86.6% (0.866×100) when expressed as a percentage of unity (100%) power factor. For a 40 degree lagging phase angle, the cosine (power factor) is 0.766 or 76.6% lagging.

The following table is provided for reference purposes.

Table 1: Trigonometric Power Factor Conversion Table

PHASE ANGLE (Degrees)	TRIGONOMETRIC COSINE	POWER FACTOR (%)
0.0	1.00	100.0
18.2	0.95	95.0
25.8	0.90	90.0

31.8	0.85	85.0
36.9	0.80	80.0
41.4	0.75	75.0
45.6	0.70	70.0
49.5	0.65	65.0

The greater the phase angle between the voltage and current waves, the poorer or lower the power factor (p.f.). Perfect power factor occurs when the voltage and current waves are in phase with each other; perfect power factor is designated as 100% power factor or unity power factor.

Loads on a distribution power system are usually inductive, as are the phase conductors and drop wires serving these loads. Capacitors are added to compensate for the tendency of the inductance to “slow” the current wave down with respect to the voltage wave. If sized properly, most of the effects of the inductance can be nullified. Unfortunately, because of continuous load variation and available capacitor sizes, continuous optimization is not feasible.

d. Load Factor Effects on Power Factor

Typical billing demand data of rural systems show a steady downward trend in average p.f. This decrease is almost directly proportional to the rising trend in kWh used. The decrease can be attributed largely to the addition of industrial-type loads and increased usage of motors as residential consumers install more and more inductive loads (larger freezers, heat pumps, etc.), which lower the power factor and operate intermittently over a 24-hour period. On a daily basis, the load distribution of these devices is comparatively uniform. The load factor of the reactive component is much higher than the load factor of the real component (that portion of load that is in phase with the voltage) because the real load component fluctuates widely on a daily basis.

$$\text{Load Factor} = \frac{\text{Average Demand}}{\text{Maximum Demand}} \quad \text{or} \quad \frac{\text{kWh}}{\text{Peak kW} \times \text{Billing Hours}}$$

Equation 3: Load Factor

Load Factor characteristics help to explain why VAR requirements are significantly greater during peak load times than off-peak. Motor driven devices that set the peak require additional VAR over the base load, which is more resistive and less inductive.

Figures 6, 7, and 8 show relationships between load and power factor during peak/off-peak periods. Data is courtesy of East Central Oklahoma Electric Cooperative, Inc., of Okmulgee, Oklahoma.

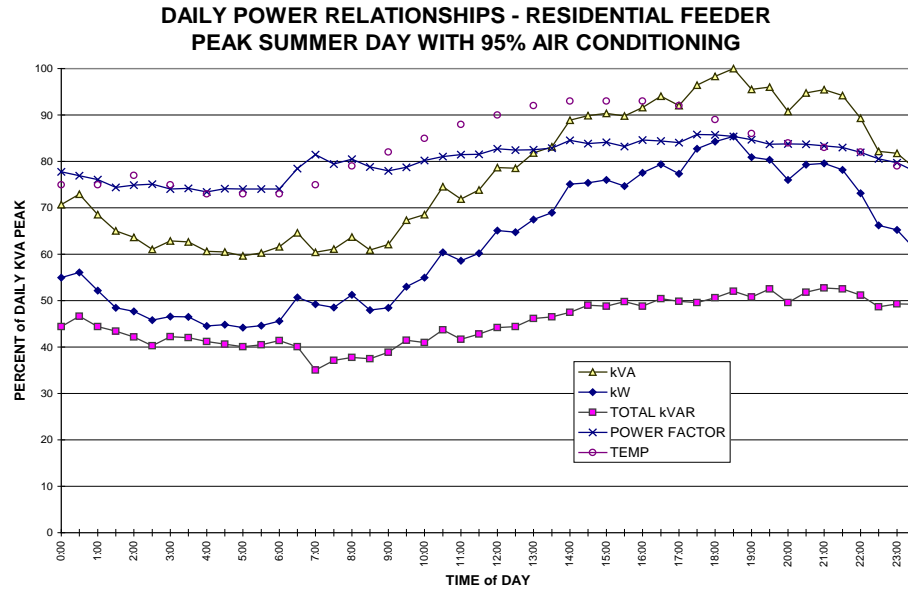

Figure 6: Residential Load—Typical Peak Summer Load

Figure 6 illustrates typical kW and kilovar load curves. Notice that, while the kW load almost doubles on this peak summer day, the kVAR requirement only increases about one-third and remains constant, while the kVA rises from 90% to 100% of peak. Figure 6 indicates that, for a residential feeder on a peak air-conditioning (a/c) summer day, any capacitors needed should be on-line from 2:00 to 10:00 p.m. on this southwestern U.S. system.

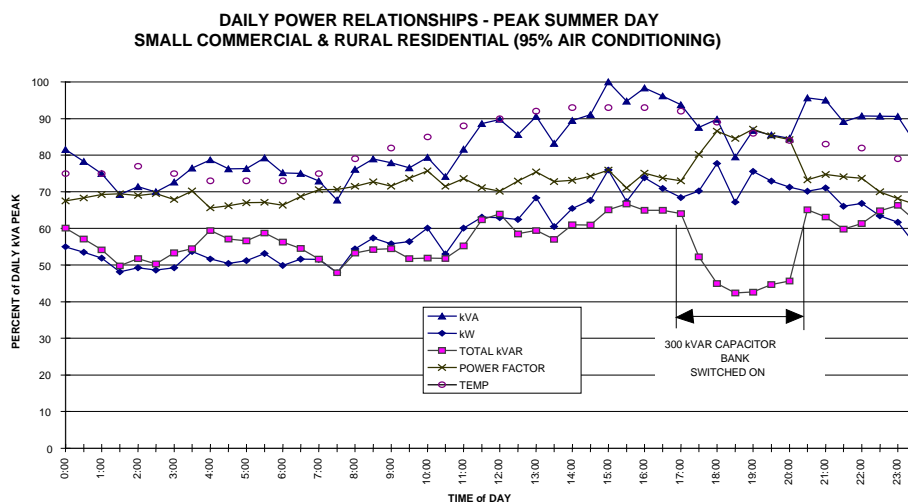

Figure 7: Effects of 300-kVAR Switched Capacitor Bank

Figure 7 shows how kVAR varies on a system as a 300-kVAR switched capacitor bank operates.

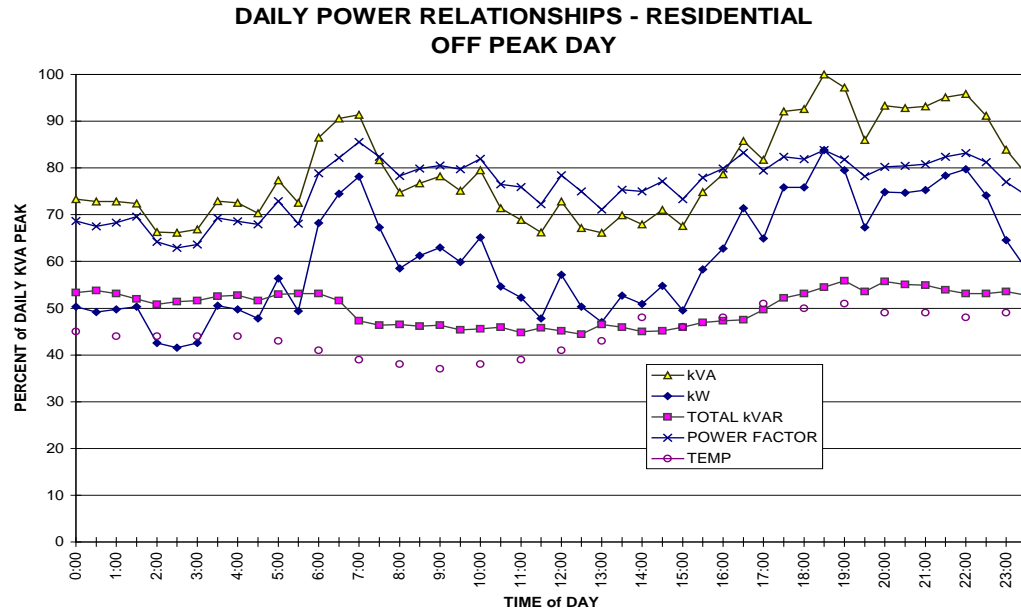

Figure 8: Residential Power Off-Peak Day

Figure 8 shows the same circuit for an off-peak (spring or fall) day.

The real power load factor on rural systems often averages about 0.40, while the average reactive load factor is about 0.70. A fairly constant kVAR load factor simplifies the problem of power factor correction. If the power factor of such a system is corrected to near unity at light load, it will remain nearer unity at peak load.

The flattening of the power factor curve at peak load in Figures 6 and 7 is not intuitive, but understandable. As a/c loads come on the system early in the peak day, when the ambient temperature is 20–30 degrees below the afternoon peak, the a/c motors are not fully loaded and cycle off for extended periods of time. Their power factor approximates 80%. But, as the temperature rises and all a/c units are on the system, they cycle off less and the motors become more fully loaded. At peak temperature, with all a/c units fully loaded and with little cycling, their power factor improves to near 95%. This helps correct the circuit power factor without additional capacitors.

e. Capacitor Sizing

Quick approximations of capacitor kVAR needed are fairly simple to make because the p.f. angles of most uncorrected loads are around 30 degrees (a p.f. of approximately 87%). In a 30–60 degree right triangle, the side opposite the 30 degree angle is one-half the hypotenuse. As a “rule of thumb,” this means that the reactive power (kVAR) is approximately half the apparent power (kVA) at 87% p.f. As discussed above, it is prudent to install less capacitor kVAR than one-half the kVA because residential a/c load p.f. actually improves near-peak load.

Graphically, the base of the triangle is the real power (kW) side and is always in phase with the voltage. The hypotenuse (kVA) is in phase with the current. As the reactive power is reduced, the phase angle decreases and the current moves closer to being in phase with the voltage. This improves the power factor.

- (1) **EXAMPLE 3.** For a load of 1,200 kVA at 87% p.f., about 600 kVAr of reactive power is required. If we provide 600 kVAr of capacitors, the leading 600 kVAr added would cancel 600 kVAr of the system's lagging inductive reactance.

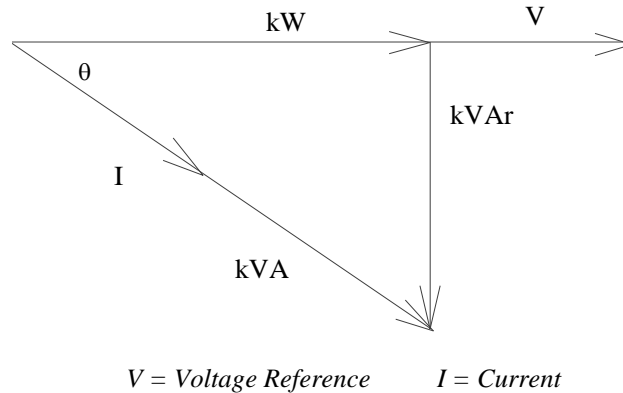

Figure 9: Power Triangle for Example 3

- (2) **EXAMPLE 4.** For 1,200 kVA at 87% p.f., find kW and kVAr.

SOLUTION:

Power Factor (Phase) Angle = Arc Cosine (0.87) = 29.54 degrees = θ

(Arc Cosine 0.87 means the angle whose Cosine is 0.87)

kW = (1,200 kVA) \times (0.87 p.f.) = 1,044 kW

kVAr = (1,200 kVA) \times Sine (29.54 degrees) = 592 kVAr

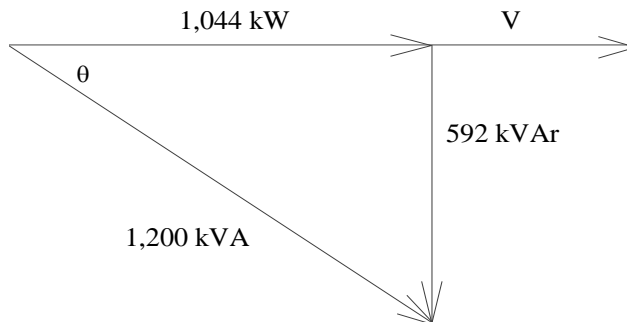

Figure 10: Power Triangle for Example 4

The difference in the 600-kVAr “rule of thumb” sizing method and the true answer of 592 kVAr is due to an 87% p.f. not being exactly equal to

30 degrees. Considering that capacitors are available in 50-, 100-, 150- or 200-kVAr sizes, the 8-kVAr difference is not a significant difference.

- (3) **EXAMPLE 5.** When a 600-kVAr capacitor bank is added, the resulting kVAr are:

$$\begin{aligned} \text{Resulting kVAr} &= 592 - 600 = -8 \text{ kVAr} \\ (\text{New Power Factor} &= \text{COS (ARC SIN } (-8 \div 1,200)) = -0.9999 \end{aligned}$$

This new Power Factor is virtually 1.00, but the p.f. is slightly leading because the negative sign means the correction was greater than needed.

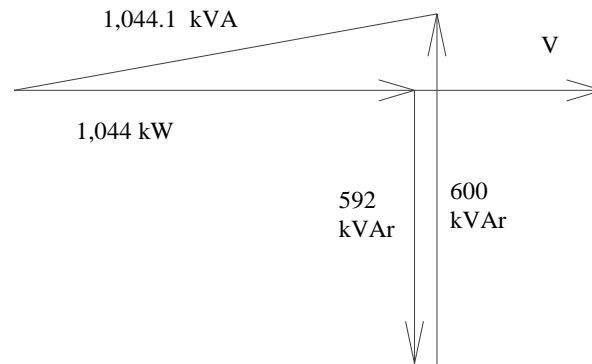

Figure 11: Power Triangle for Example 5

The 1,200 kVA system load has now been reduced to 1,044.1 kVA. The current on a 7,200-volt system would be reduced from 56 to 48 Amps. The VAR needed to correct any existing power factor and demand can be calculated by first determining the existing VAR using the method detailed in the solution related to Figure 10. Then, using the same demand and the desired power factor, solve for the resulting VAR that should exist after the power factor correction is achieved. The difference in the two VAR values is the maximum total VAR of capacitors to be added.

f. Voltage Improvement with Capacitors

In addition to improving the system power factor, capacitors also provide voltage drop improvement. Because of a capacitor's leading current, which flows through the system's lagging inductance, capacitors cause a voltage rise on the system. It is not uncommon to experience a 2- to 3-volt rise (on a 120-volt base) with 300 kVAr of capacitors on 7.2-kV systems. For the same kVAr amount of capacitors, the rise would be half of that on a 14.4-kV system (twice the voltage, half the current).

Voltage rise is determined by multiplying the capacitor's leading current by the inductive reactance (X_L) of the portion of the distribution system between the distribution voltage source and the capacitor location. The resistive (R) portion of the impedance involved causes a voltage drop in phase with the voltage and, thus, does not play a role with the capacitor in creating voltage rise.

Voltage rise from the power source to the location of a shunt capacitor (or anywhere on the line between the capacitor and the power source) is calculated as follows:

$$\text{Voltage Rise} = \text{Capacitor Current (Amps)} \times \text{Conductor (System) Reactance (Ohms)}$$

Equation 4: Capacitor Voltage Rise

where:

$$\text{Capacitor Current} = [\text{kVAr (per phase)}] \div [\text{kV (line to neutral)}]$$

Equation 5: Capacitor Current

and

$$\text{Conductor Reactance} = R + j X \text{ (system component impedance near capacitor's location)}$$

This voltage rise equation provides the total voltage rise from the generator to the capacitor, but, since most of the impedance is on the distribution system, that is where most of the rise occurs.

The calculated voltage rise is the actual rise on the primary system. To make it a usable and understandable number, voltage rise should be referred to the delivery voltage (120-volt) base. Calculated primary voltage rise is, thus, divided by the primary line's potential transformer ratio. This is the primary line-to-neutral voltage divided by 120 volts (which is 60 for 7,200-volt systems and 120 for 14.4-kV systems).

- (1) EXAMPLE 6. Find the voltage rise caused by a three-phase, 300-kVAr capacitor station located on a 12.47/7.2-kV feeder whose impedance at the node point nearest the capacitor station is:

$$Z = R + j X \text{ ohms} = 13.4 + j 13.3 \text{ ohms (See Figure 12)}$$

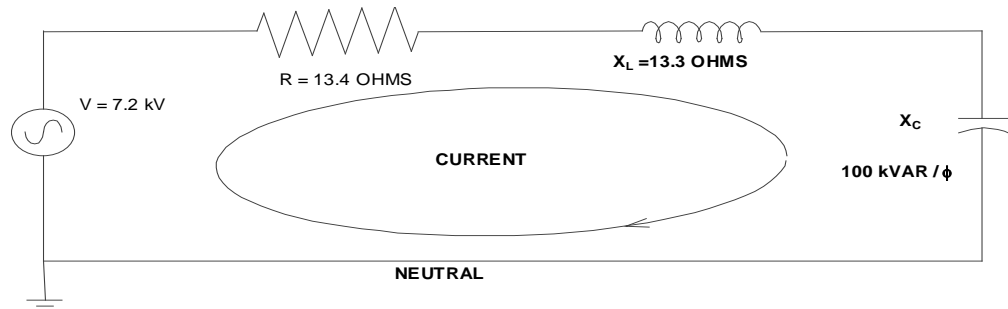

Figure 12: Voltage Rise from 300 kVAr of Capacitors

SOLUTION: Capacitor current calculations use capacitor kVAr per phase divided by *line-to-neutral* voltage.

$$\text{Capacitor Current} = \left(\frac{300 \text{ kVAr}}{(3) \times (7.2 \text{ kV})} \right) = \left(\frac{100}{7.2} \right) = 13.9 \text{ Amperes}$$

(Note: Each 100-kVAr capacitor draws 13.9 Amps on a 7.2-kV system.)

$$\text{Voltage Rise} = (13.9 \text{ Amps}) \times (13.3 \text{ ohms}) = 184.7 \text{ volts (7.2-kV base)}$$

Referred to the delivery base voltage or 120-volt base, divide true volt rise on the primary by the transformer ratio.

$$7.2 \text{ kV} \div 120 \text{ V} = 60 \quad (60:1 \text{ ratio})$$

$$\text{Voltage Rise on a 120-volt base then} = 184.7 \div 60 = 3.08 \text{ volt rise}$$

This means that the leading 13.9 Amperes per phase capacitor current flowing through the 13.3 ohms of *reactive* system impedance causes the voltage to rise from the distribution voltage source to the capacitor. This results in a 3.08-volt rise at the capacitor location *and beyond the capacitor*.

Adding a second 100-kVAr capacitor per phase will double the voltage rise to 6.16 volts on each phase.

This voltage rise starts at near zero at the source and uniformly rises to a peak of 3.08 volts at the capacitor location. The capacitor voltage rise can be calculated at any point between the distribution voltage source and the capacitor (the line section along which the capacitor's current flows) by the same method as above. The voltage rise caused by the capacitor levels out at the capacitor location (the capacitor current has reached its load), but the 3-volt rise is seen over the entire system past the capacitor.

The percent voltage improvement due to a shunt-connected capacitor installation, at the capacitor location, is calculated as follows:

$$\% \text{ Voltage Rise} = \left(\frac{\text{Voltage Rise}}{\text{Voltage Base}} \right) \times 100$$

Equation 6: Capacitor Percent Voltage Rise

In the above case:

$$\% \text{ Voltage Rise} = \left(\frac{3.08}{120} \right) \times 100 = 2.57 \%$$

The textbook solution is:

$$\% \text{ Voltage Rise} = \frac{(\text{ckVAR}) \times (\text{X}) \times (\text{d})}{10(\text{kV})^2}$$

Equation 7: Percent Voltage Rise Any Point from Source to Capacitor

Where:

d = length of line, circuit-miles (from distribution voltage source to capacitors)

ckVAR = total capacitor kVAR (1 ϕ and 3 ϕ lines, delta-connected capacitors), *or*
 = 1/2 total capacitor kVAR (V ϕ lines), *or*
 = 1/3 total capacitor kVAR (3 ϕ lines, Y-connected capacitors)

X = reactance, ohms per circuit-mile (1 ϕ and 3 ϕ lines), *or*
 = 1/2 single-phase reactance, ohms per circuit-mile (V ϕ lines)

kV = line-to-ground kilovolts (1 ϕ and V ϕ lines, and 3 ϕ , Y-connected capacitors), *or*
 = line-to-line kilovolts (3 ϕ , Delta-connected capacitors)

In Example 6, note the closeness of the resistive (13.4 Ω) and the reactive impedance (13.3 Ω). This closeness is typical of conductor that has a resistance fairly equal to its reactance (1/0 through 4/0 ACSR). Smaller conductors have lower X/R ratios. Larger conductors have higher X/R ratios. Resistance decreases much faster than reactance as conductor size gets larger. Reactance is a function of conductor spacing.

Table 2: Conductor Impedance

ACSR Conductor Size	CONDUCTOR IMPEDANCE ACSR - Ohms per Mile Using 8-foot Crossarm Spacing		% VOLTAGE RISE per Mile on 120-volt Base with 100 kVAr per Phase	
	Resistance (R)	Reactance (X)	Line-to-Neutral Voltage	
			7,200	14,400
4	2.47	0.655	0.126	0.0631
2	1.41	0.642	0.123	0.0619
1/0	0.888	0.656	0.126	0.0632
4/0	0.445	0.581	0.112	0.0560
267 kcmil	0.350	0.465	0.0896	0.0448
477 kcmil	0.196	0.430	0.0829	0.0414

Impedance Source: Westinghouse Electrical Engineering Reference Book—Distribution Systems

System operators should take advantage of the voltage rise associated with capacitors to help offset normal system voltage drop. However, caution should be exercised to prevent over application of capacitors for the purpose of raising voltage because the current drawn by capacitors can increase line losses, especially if capacitors drive the system into a leading power factor.

Capacitors can be an inexpensive short-term fix for a voltage problem, but capacitors can significantly increase line losses and probability of harmonic influence (interference) on nearby telecommunications lines.

In addition to using capacitors to simply offset normal system voltage drop, capacitors can be an integral part of a Conservation Voltage reduction (CVR) program.

(2) CVR Considerations with Existing Capacitive Support

Many cooperative are looking at options at saving members energy; CVR always comes up as a potential topic. This is typically accomplished via a load tap changer (LTC) or through voltage regulators. To maximize the benefit received from CVR, feeder voltage profiles should be flattened to the extent possible. This allows the greatest level of voltage reduction to be obtained along the entire feeder length, and capacitors can play a significant role in accomplishing this. Study is required to determine the proper amount of capacitance, location, and switching parameters.

It is particularly important when using CVR for peak demand reduction to ensure the capacitors will quickly switch in as needed during a CVR event and then quickly switch out once the CVR event is over. In some cases, it may prove beneficial to actually allow the power factor to go slightly

leading during a CVR event to lower peak demand, as long as the duration of the event is relatively short.

Capacitors are placed on a distribution system for a variety of reasons:

- Power Factor Correction
- Voltage Support
- Easing of Capacity Constraints

When employing a CVR scheme, special consideration should be given to the purpose of the existing capacitor and how it is currently being switched. Capacitor banks can be switched using a variety of different triggers:

- Voltage
- kVAr
- Current
- Temperature
- Time

Each capacitor bank location should be analyzed based upon its location on the distribution system, as well as its impact on the voltage profile of the system during a CVR event. Adjustments to the capacitor switching scheme may need to be made; for example, a capacitor bank switching on voltage may need to have supervised switching to limit the voltage rise during a CVR event.

A capacitor bank close to the substation may not need to be adjusted, while a bank placed out on the distribution line may require changes to the switching scheme. The preferred location of a capacitor bank may need to be a hybrid style that isn't quite optimal for power factor correction or other engineering reasons, but rather provides a compromise between CVR and the original purpose of the capacitor bank.

3 CAPACITOR CONCERNS

a. Overcurrent and Overvoltage Protection

Lightning surges may cause damage to capacitors. Capacitor units connected line-to-neutral on a multigrounded neutral system provide a low-impedance path for lightning surges. This low-impedance characteristic makes capacitors susceptible to lightning surge events. Lightning strikes have damaged capacitor bushings as a result of severe instances of flashover. However, the more probable lightning damage to capacitors is the breakdown of the insulation between the capacitor's internal elements and the capacitor case.

A capacitor attempts to maintain constant voltage across its terminals and, if the voltage begins to change, the capacitor conducts charging current through itself of sufficient amplitude to keep the voltage constant. When lightning strikes a capacitor, the surge impresses a very high voltage across the capacitor. The capacitor then, in an attempt to maintain the impressed voltage, charges to the surge voltage magnitude by passing enormous charging current. This action can cause the unit to fail from the internal heat generated by the large charging current.

Capacitor failure is usually indicated by a severely bulging tank case, ruptured tank case, other catastrophic physical evidence, or no visible physical evidence on the capacitor but by simple observation that the fuse protecting the capacitor has blown. Slight bulging or blooming of a capacitor tank is not necessarily indicative of capacitor failure because capacitors can withstand considerable overcurrent conditions.

Capacitors should conform to the *IEEE Standard for Shunt Power Capacitors* (Std. 18-1992). This standard expects a capacitor to provide continuous operation, provided that none of the following limitations are exceeded:

- (1) 135% of nameplate kVAr,
- (2) 110% of rated root mean square (rms) voltage and crest voltage not exceeding 2.83 times the rated root mean square voltage (including harmonics but not transients), and
- (3) 180% of rated root mean square current (including fundamental and harmonics).

Capacitors suspected of being damaged should be tested using a commercially available capacitor checker. Testing could also be conducted by using an audio oscillator, a voltmeter, a resistor, and an inductor of known inductance. The resistor would be wired in series with the parallel connection of the capacitor and inductor and the circuit energized with the audio oscillator across this series parallel connected circuit. The voltmeter would be connected to measure the voltage across the capacitor or inductor and the frequency of the oscillator adjusted for a minimum voltage reading. At this frequency, the capacitor and inductor should be in resonance, where the inductive reactance should equal the capacitive reactance.

The inductive reactance of the inductor can be calculated by multiplying the known inductance value by the measured frequency and multiplying this value by 2π . The capacitance should be equal to 1 divided by the product of the calculated inductance multiplied by 2 times π times the resonant frequency. This calculated capacitance should be within the rated tolerances of the shunt capacitor's capacitance which is calculated according to the following formula.

Capacitance of a power shunt capacitor is equal to:

$$C = \frac{1000 \times kVAr}{2\pi \times f \times V^2}$$

Equation 8: Capacitance

Where:

- C = capacitance in microfarads (μF)
- kVAr is the capacitor's rated kVAr
- f = rated frequency of capacitor (60 Hz)
- V = rated voltage of the capacitor in volts

For example, plugging rated values for a 50-kVAr, 7,200-volt capacitor into the equation results in a capacitance of 2.56 μF .

If the capacitance calculated from the test varies significantly from the rated capacitance calculation, then the capacitor should be retired.

Power circuits can remain in operation with part or all of a capacitor bank out of service. But the portion of a capacitor bank that is not in service does not provide either voltage improvement (rise) or power factor correction. Wide voltage variations can occur on multiphase systems that experience the loss of one or more—but not all—installed capacitors of a capacitor bank. Loss of some—but not all—capacitors on a multiphase line can also cause shifting of phase angles, leading to system unbalance.

Shifting phase angles away from the normal 120 degrees causes many problems on a three-phase power system, such as motor growling, motor overheating, difficulties in starting loaded three-phase motors, and blowing or tripping of motor protection devices. Thus, single- or unbalanced-phase capacitor use should be avoided. When one phase of a three-phase capacitor bank is out of service, the whole bank should be taken out of service.

In the event of capacitor failure, it is desirable to isolate the failure from the power system and minimize the damage, with no interruption in service. The emphasis, therefore, is upon protection of the circuit instead of the capacitor. However, if the capacitor unit contains polychlorinated biphenyls (PCBs), extra care is required to clear the failed unit before tank rupture and an expensive cleanup of the affected area as is required by the Environmental Protection Agency (EPA). System operators would be prudent to remove all PCB capacitors from use and properly dispose of them in accordance with EPA regulations (*40 CFR Part 761—Polychlorinated Biphenyls (PCBs) Manufacturing, Processing, Distribution in Commerce, and Use Prohibitions*). Capacitors manufactured since 1978 should not contain PCBs and do not have the same health and disposal concerns as capacitors with PCBs.

PCBs proved to be an excellent dielectric material for use in capacitors. However, scientific studies conducted raised concerns that PCBs may present a health hazard to humans, and PCBs were subsequently banned for use in the manufacture of capacitors and many other products. Except within the vicinity of animal feedlots and grain harvesting facilities, PCB-containing products were allowed to remain in use, but EPA issued regulations on the use of such products. EPA promulgated these PCB product use regulations because PCBs will not readily decompose or break down and can be expected to retain their chemical composition for many years. These regulations include the proper method of disposal of products containing PCBs and PCB waste materials. EPA requires that certain PCB-containing products (which includes capacitors) be properly contained and sent to a suitable toxic disposal facility. The location of the nearest facility can be obtained by contacting the capacitor manufacturer or the regional EPA office.

Capacitors need to be provided with lightning arresters and proper fusing or short-circuit protection for reasons other than lightning. This protection is also needed to prevent capacitors from being damaged by transient over voltages caused by switching operations, arcing grounds, accidental conductor contact with higher voltages, disturbances caused by other arresters, and resonance or near resonance caused by motors while starting. Protection is best provided with maxi-block silicone carbide or metal oxide varistor (MOV) lightning arresters. Connections to and from the arresters and capacitors and the arrester grounding provisions should be made using the shortest leads practical, attempting to keep the leads as straight as possible. A capacitor should also be provided with a fuse or short-circuit protection that is designed to function under 135% of the capacitor's nameplate current rating. Fusing guidelines are included in Section 4i of this bulletin.

b. Harmonics

Capacitors act as a path to ground for the harmonic currents of a power system's 60-Hertz (Hz) power wave. The impedance offered by a capacitor is calculated using the following formula:

$$X_c = \left(\frac{1}{2\pi f C} \right)$$

Equation 9: Capacitor Impedance

Where:

X_c = Capacitive reactance

π = 3.1416

f = Frequency (60 Hz for U.S. power systems)

C = Capacitance in Microfarads

As can be seen from the formula, a capacitor's impedance decreases as the frequency increases. Thus, higher order harmonic currents, or currents at multiple frequencies of the power system fundamental 60-Hz wave, can flow through a capacitor easily.

Nonlinear loads such as transformers (especially transformers with poor-quality cores) generate harmonics. The magnitude and number of harmonics generated by a transformer is directly related to the magnitude of the voltage used to energize the transformer. The higher the energizing voltage, especially as the energizing voltage exceeds the transformer's nameplate rating, the higher the magnitude and numbers of harmonics generated by the transformer.

Harmonic currents travel down the lines looking for a low impedance path to ground. Underground primary power cables are predominately capacitive and also provide this path. Any odd-numbered triple (180, 540, 900-Hz, etc.) of the fundamental 60-Hz voltage wave is likely to cause problems, because all three phases of the odd-numbered triple harmonics are in phase with one another on a 3-phase system and, thus, add up rather than cancel one another where they flow to ground. This can cause overheating in power equipment and neutral conductors. The 9th harmonic, a triple harmonic, can have the greatest effect on capacitors because it is a common transformer-generated harmonic and capacitors offer low impedance at 540 Hz.

With a path to ground, harmonic currents can flow along the phase conductors and neutral conductors of a power line and can induce currents in parallel telecommunications cables. If high enough in magnitude, induced harmonic currents can render a telecommunications system unusable. The power system operator must design electric facilities to minimize the possibility for harmonic induction. The primary frequency spectrum for wire-line telecommunications systems is from 40 Hz to 3,000 Hz. But the frequencies from 100 to 2,500 Hz are the most critical to causing objectionable harmonic interference. These same frequencies are within the range of typical harmonics generated on a power system. Capacitors can exacerbate normal power line harmonic current flow by providing them a lower impedance path, thus causing their magnitudes to be higher than they otherwise would be without capacitors connected. In worst-case situations, capacitors can also create resonant conditions on the power system that can cause extremely high magnitudes of harmonic current and voltage that can severely affect telecommunications operation.

Methods to alleviate harmonic problems associated with capacitors are discussed below, but you first have to know the issue exists. Placement of capacitor banks in areas where higher levels of harmonics are known to exist should prompt further investigation *before* installation. It's better to avoid potential harmonic interference through initial design efforts than be forced to solve a problem once equipment is in place.

(1) Change Capacitor Location

Telecommunications noise problems created by capacitors can often be remedied by moving the capacitors to a new location. The ideal objective is to move the capacitor bank toward the substation to a location where the power conductors between the capacitor bank and the substation do not parallel any telecommunications circuits. Remedial success is high when the offending capacitors have caused a resonant condition on the power line and the two utilities parallel one another for a significant distance.

Resonant conditions usually occur at a single frequency, often an odd multiple of 60 Hz, such as 300, 540, 900 Hz, etc. At the resonant frequency, the power circuit's inductive reactance (between the capacitor bank and the substation serving the bank) equals the power circuit's capacitive reactance. With the circuit impedance so drastically reduced to only a small resistive component, an abnormally high magnitude of current can flow at the resonant frequency, significantly improving the chances for induction and resulting in objectionable harmonic noise in neighboring telecommunications circuits. At the resonant frequency, voltage on the power circuit can also become high and could lead to damage of connected power line equipment and/or system operating problems.

Moving the capacitor toward the distribution voltage source helps improve a noise situation in two ways. First, changing the capacitor bank location can detune the resonance which, by itself, can help to reduce the noise. Moving the bank so there is limited parallel exposure of the two utilities' circuits between the capacitor location and the substation minimizes possible induction of harmonics into the telecommunications circuits and adds to the improvement.

Moving a capacitor bank is not necessarily a permanent solution. Noise problems could arise again as circuit loading and balance changes with time, possibly creating resonant conditions at different harmonics. In addition, future utility construction could result in new longer stretches of parallel exposure between the utilities and cause renewed noise problems. Joint utility planning and coordination can help to avoid such problems.

(2) Change Capacitor Size

Adding capacitors at a capacitor bank suspected of causing a resonant condition can sometimes change the circuit capacitance enough to cancel the resonance and help alleviate a noise problem. Such a solution, however, needs to be addressed carefully to be certain that resonance is not moved to another critical power line harmonic frequency, resulting in continued or worsened telecommunications noise. Care is also needed to

be certain the added capacitance does not cause the power circuit to have an objectionable leading power factor.

Because of the reduced power/telecommunications circuit exposure, moving capacitors as discussed in Section 3b (1) of this bulletin can be more effective in alleviating noise problems than adding capacitance.

For the same reason as noted in Section 3b (1), load growth, new utility construction, etc., can upset any success attained in adding capacitance to a capacitor bank to reduce a noise problem. Again, proper planning, design, and coordination with all neighboring utilities is extremely useful in minimizing problems.

(3) Harmonic Filters

Another noise-reducing remedy involves blocking the harmonic ground path by inserting a tuned filter (specifically manufactured for the purpose) in the capacitor ground connection. This filter would take the place of the grounding switch shown in Figure 13. The filter is a harmonic saturable reactor which, during installation, is experimentally tuned so that, at the offending harmonic frequency, it acts as a high impedance, preventing current at that frequency from flowing on the power line. At 60 Hz, the filter provides a low-impedance connection to ground, helping to maintain system grounding integrity.

A filter installation may need to be retuned as the loads and electric system change. At some point, the electric system could change to such an extent that the tuning needed for effective noise alleviation may be outside the range of the filter's core size as installed and a new filter may be necessary.

Because the ground wire is hidden in a standard saturable filter installation, use of the filter is not acceptable to some utilities.

(4) Ungrounded Capacitor Banks

Another noise-reducing remedy involves blocking the harmonic ground path by floating the wye point on the capacitor bank and denying harmonic current a path to ground. **However, because of the safety concerns, utility systems should consider this solution only as a last resort.** While the neutral is floated, the ungrounded capacitor cases can become energized to primary-line voltage levels and present a hazard to line crews who work on them.

If no other remedial effort is feasible and this solution is determined to be necessary, then special operating procedures should be implemented and strictly observed. For safety reasons, to assure the capacitor cases and the power system neutral are effectively grounded temporarily, the floating

wye should be grounded, usually with a solid switch (solid blade cutout). This grounding switch would be used during manual switching or repairs on the capacitor bank or the power system within the vicinity of the capacitor bank. For normal operation, after the capacitors are energized, the grounding switch is open and the wye-point of the capacitor bank is placed in the ungrounded mode.

It is recommended that a sign be added to the pole for electric line crews such as:

WARNING!
UNGROUND WYE CAPACITORS

GROUNDING SWITCH
CLOSE GROUNDING SWITCH BEFORE OPERATING
LEAVE SWITCH OPEN WHEN FINISHED

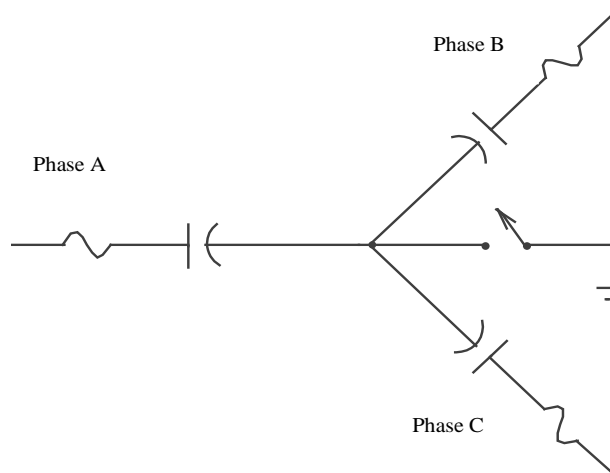

Figure 13: Ungrounded Capacitor Bank

Map records should also show locations of nonstandard capacitor connections.

c. Switching Transients²

A capacitor is an energy-storage device whose voltage cannot change instantaneously. As such, the energization of a capacitor bank results in an immediate drop in system voltage toward zero, followed by an oscillating transient voltage on the 60-Hz system voltage waveform (as shown in Figure 14), which will decay over time as the system recovers and returns to steady-state. The initial rebound will overshoot the system voltage by a magnitude equal to the

² *Capacitor Switching Transients: A Best Practices Guide*. TVPPA R&D Project CS-1, 2011.

difference between the system voltage and the capacitor voltage at the instant of energization. Or, put simply: for every volt the system is pulled below its normal level, the overshoot will be one volt *above* normal. The most severe transient, then, will occur when an uncharged capacitor is switched on at a system voltage peak, leading to a theoretical peak voltage of 2.0 per unit, or twice the nominal system value.

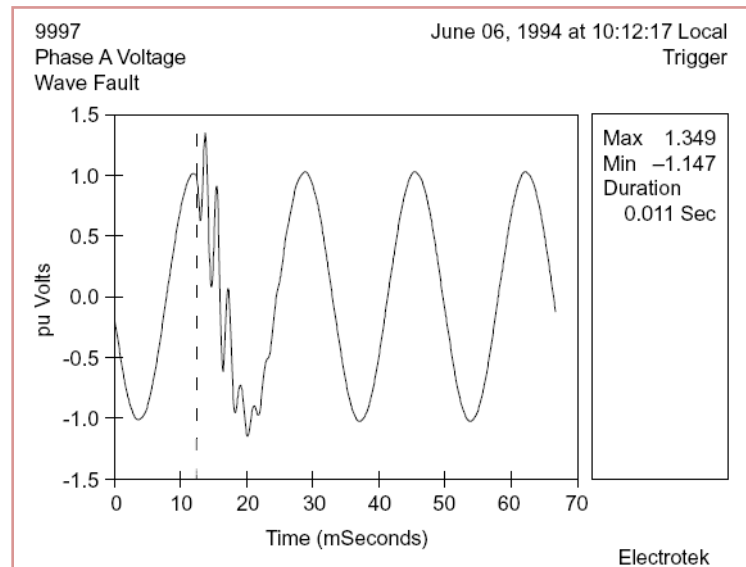

Figure 14: Typical Distribution Capacitor Switching

In practice, capacitor switching transients generally do not reach the theoretical maximum magnitude; system losses, loads, and other capacitances will tend to damp the excess voltage. Figure 16 shows the feeder voltage transient for the simplified model of Figure 15 when the 150-kVAR bank is switched on. Typical transient magnitudes fall in the 1.3 to 1.5 per-unit range, with frequencies ranging from 300–1,000 Hz (medium- to high-frequency), though there are special cases in which these levels could be exceeded. These special cases can result in varying degrees of risk to components of the distribution system.

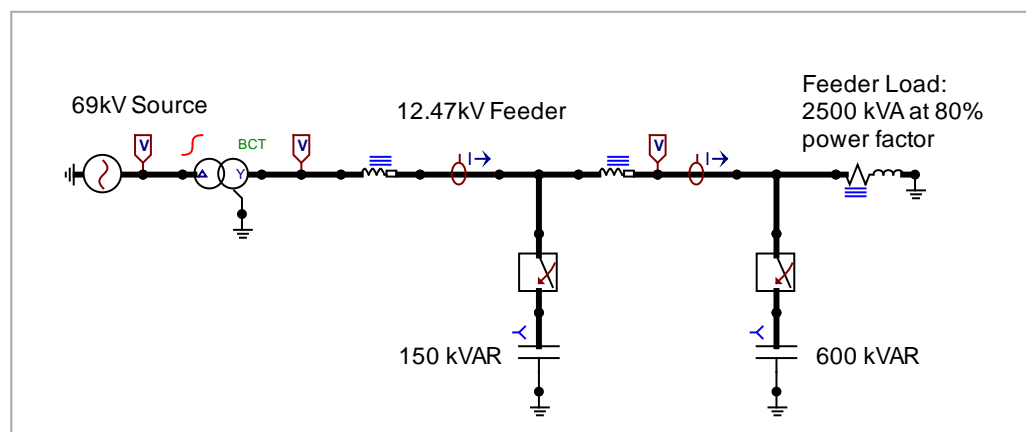
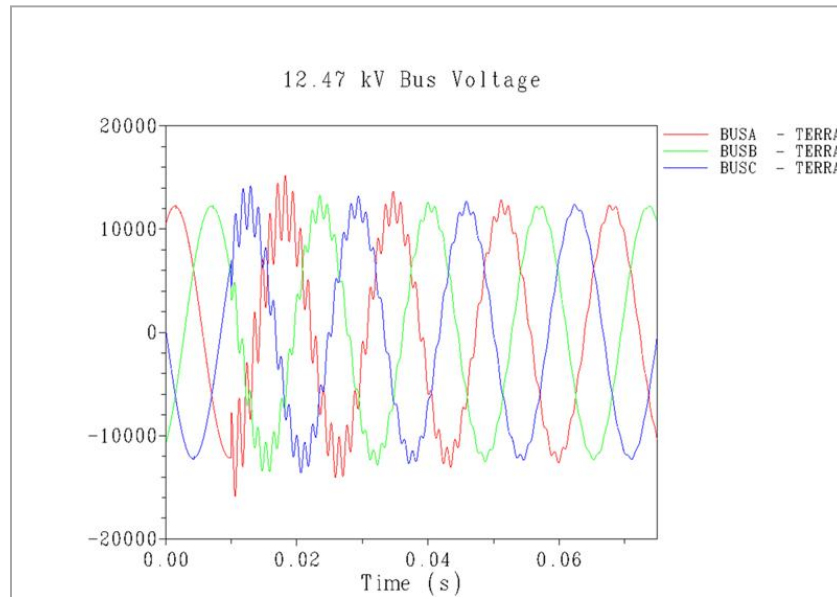

Figure 15: Simplified Distribution Feeder Model**Figure 16: 150-kVAr Bank Switching; 600-kVAr Bank Off**(1) Back-to-Back Capacitor Switching

“Back-to-back” switching is a term used to describe the energization of a shunt capacitor bank when another is already in operation on the distribution system. This type of event produces high-frequency, high-magnitude transient currents that flow between the capacitor banks.

The frequency and current level of the transient produced by a back-to-back switching event is dependent on a number of factors and generally lasts only a fraction of a cycle, but can potentially reach peaks greater than 2.0 per unit (pu) between the banks. Figure 17 shows the transient currents and voltage levels between the capacitor banks in Figure 15 when the 600-kVAr bank is energized with the 150-kVAr bank already in service.

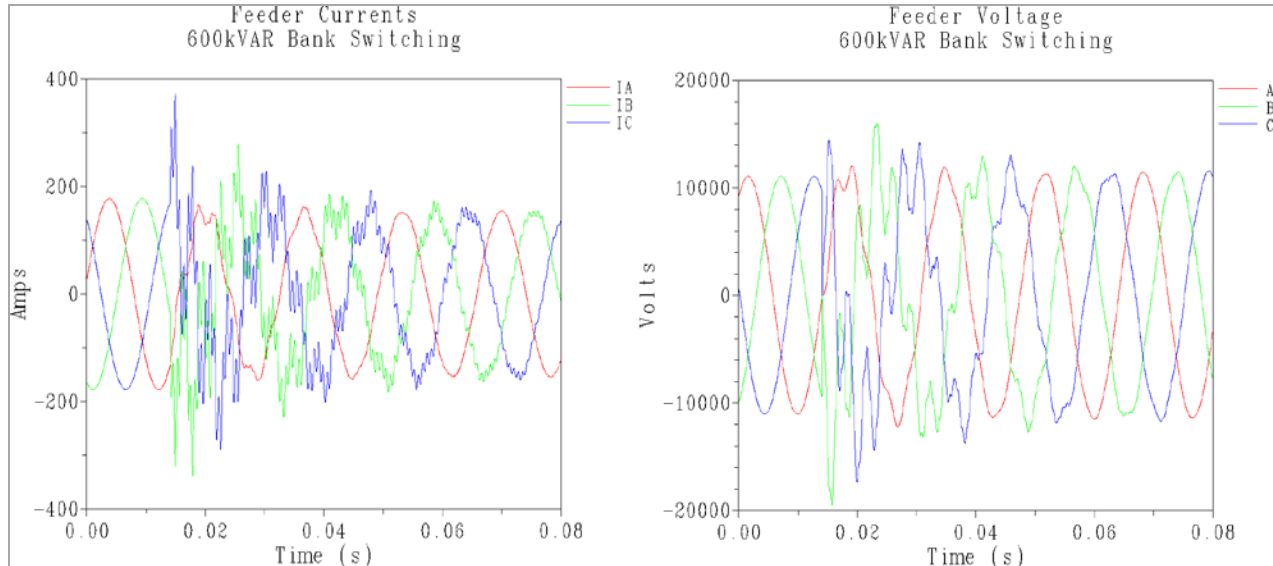

Figure 17: Transient Effects of Back-to-Back Switching Event

(2) Capacitor Bank Restrikes

A capacitor switching device must possess sufficient strength to withstand the voltage levels across its terminals during a switching event. Capacitor banks are de-energized at current zeroes, which correspond to system voltage peaks; a switch for a grounded-wye-connected bank will be subjected to 2.0 volts pu a half-cycle after it interrupts the capacitor current.

If the switch cannot withstand this level of potential and restrikes at twice the system voltage, a transient voltage magnitude of 3.0 pu can occur. A switch on an ungrounded-wye capacitor bank may be subjected to voltages greater than 2.0 pu after a de-energization; it is possible, when delays occur between the attempted openings of the phases of a switch, to develop a transient voltage of more than 6.0 volts pu (six times the system voltage) during a restrike event.

(3) Capacitor Switching Transients at Consumer Facilities

Because utility distribution systems operate at high voltage and utilize equipment that has substantial momentary current withstand capability, they are (for the most part) not threatened with damage or failure by typical switching transients. Equipment at the utilization level, however, tends to utilize sensitive (and sometimes highly frequency-dependent) electronic devices at low-voltage levels, meaning that even a small overvoltage can, at best, be a severe nuisance and, at worst, cause damage or failure.

The severity of a transient on both the utility and consumer sides of the system is dependent on a number of factors, familiarity with which will be important when determining expected magnitudes and mitigation strategies. The VAR ratings of the capacitor banks in question are certainly of great importance. The bank's configuration whether it is connected as a "delta" or "wye" bank plays a role as well.

Of further importance is certain information about the distribution lines on which the capacitor bank (or banks) is connected, namely: the distribution line impedance and the various lengths of line involved (from the substation to the capacitor bank and from the capacitor bank to any additional downline banks). The *positive sequence* and *zero sequence* impedance values are of primary concern when predicting transients. These factors will all contribute to the severity of transients on the consumer system as well as the distribution system. A few other factors are in play, however, in certain situations on the consumer side of the system.

During a distribution capacitor switching event, typical transient voltages produced on consumer systems range from 1.2 to 1.4 pu volts. These transient voltages can be magnified, however, if the consumer has installed low-voltage capacitors for power factor correction, or by certain step-down transformer sizes.

Low-voltage capacitor banks are typically used by commercial and industrial facilities to improve the power factor as monitored by their electric utility to lower or avoid power factor penalty charges; because these consumers tend to have motor loads that draw the reactive power in the first place, they also tend to have devices (adjustable-speed drives and other process equipment) that use the power electronics components that are most sensitive to over voltages. Vulnerability is not limited to these devices, of course; computer networks and other electronic devices can be damaged or fail due to large over voltages.

In addition to the individual capacitor bank sizes, the *relationship* between the sizes of a distribution bank and a consumer's power factor-correction bank will affect the low-voltage transient level; if the distribution capacitor bank is significantly larger (ten times larger or more) than the consumer bank, transient voltage magnification is more likely. Additionally, the relationship between the energizing frequency of the distribution bank and the resonant frequency of the consumer system affect the transient magnification. These frequencies are dependent upon

the sizes of the capacitor banks and the transformers, the system voltage, and the short-circuit power available from the transmission source.

A typical distribution feeder model, down to the consumer level, is shown in Figure 18. This is a more detailed feeder model than the one used previously, as it places the various connected loads at appropriate points to more accurately reflect the behavior of the distribution system and represents an actual distribution feeder. The model includes a 600-kVAR switched capacitor bank on the distribution level and a 60-kVAR fixed power factor-correction bank on the consumer level, both connected in a grounded-wye configuration. The substation transformer is delta (primary)/grounded-wye (secondary), the distribution transformer is grounded-wye/grounded-wye, and the line and source impedances are modeled based on actual feeder values.

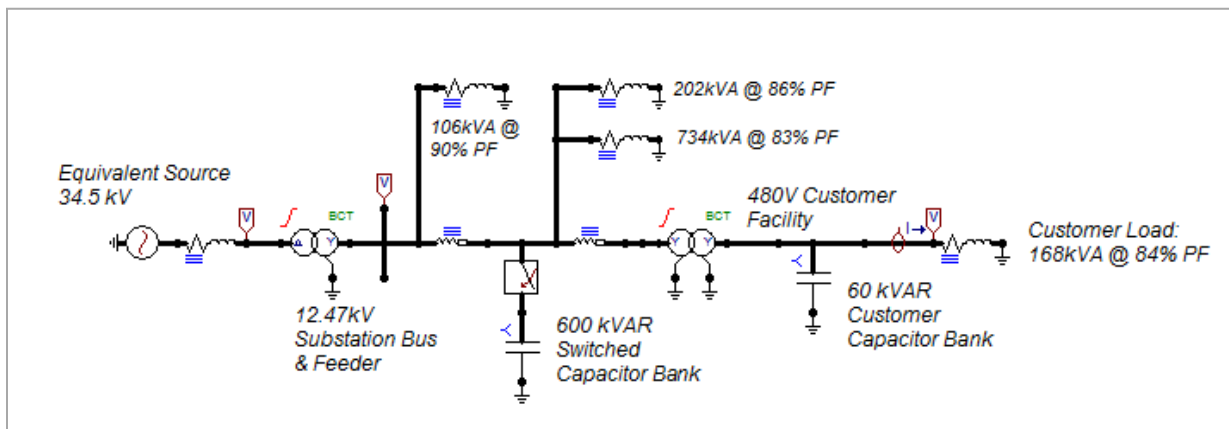

Figure 18: Distribution Feeder Model with Consumer Facility

The transients created on the consumer and utility voltages by the switching of the distribution capacitor bank are shown in Figure 19. The presence of actual source and load models and conductor impedances has the effect of significantly damping the distribution system transient, as is seen in the figure. The consumer-level transient, however, is high-frequency and much more severe, exceeding 2.3 pu volts (1,100 V) on the A-B phase.

It should be noted here that the kVAR values, transformer properties, and transmission source values were not chosen to maximize the transient magnification; with the exception of the consumer capacitor bank, every quantity in this model is based on a real distribution feeder. Furthermore, the size of the consumer bank was chosen not because of its relationship to the distribution bank, but because it is a realistic value that would improve the facility's power factor from 84% to 97% (likely reducing the penalty charges incurred by the consumer).

This simulation clearly illustrates the potential consequences of installing capacitor equipment without regard to distribution system conditions; the level of overvoltage produced by the operation of the utility capacitor switch would almost certainly be disastrous for the consumer. Adjustable-speed drive overvoltage protection will typically trip at values as low as 1.2 pu, meaning that a transient voltage at 2.3 pu would likely cause facility-wide process equipment shutdown. An overvoltage of this magnitude could also potentially damage any low-energy surge arresters or transient suppression equipment in use.

If surge protection equipment is not in use or fails to damp or eliminate the transient on the 120-Volt (V) system (allowing a transient voltage of nearly 280 V if phase A is used for 120-V service), severe computer damage and failure can occur quickly. At the 120-V level, even small overvoltages can cause computer issues such as memory alteration and data loss. Voltage surges can decrease the life spans of fluorescent bulbs and ballasts as well.

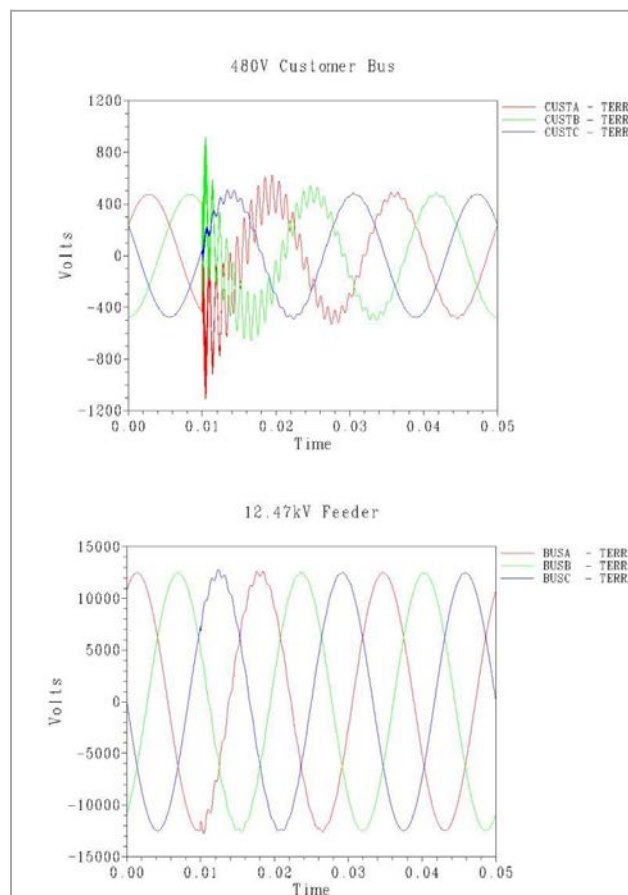

Figure 19: 600-kVAr Switching Transients at Consumer and Utility Level

d. Transient Mitigation Strategies

(1) Sizing Capacitor Banks and Detuning Circuits

In certain situations where transients are being magnified at low voltage, simply changing one or more circuit parameters can sometimes help to reduce the overvoltage. Changing capacitor bank sizes, moving banks or removing them from service, or even choosing alternate step-down transformer sizes can decrease the severity of transient voltages. This is generally a viable option at both the distribution level and the consumer level. Transient prediction tools can also prevent transients from becoming a problem at all if used by utilities or consumers before installing capacitor banks.

(2) Sophisticated Switching Controls

Some capacitor bank control devices are equipped with “zero-crossing” or “synchronous closing” capability, which allows them to close in each phase of a capacitor bank at or near a voltage zero in order to minimize the resulting transient. Figure 20 shows the voltage waveforms for the same model shown in Figure 18, but with the capacitor phases switched independently at zero crossings. While the transient on the 480-V level is not *completely* eliminated (even the most sophisticated switching controls are subject to errors of a fraction of a millisecond, and may not close at a perfect zero), the overvoltage is now less than 1.05 pu, appearing as merely a blip on the waveform; the feeder voltage experiences no transient effects at all.

Many capacitor controls also possess the ability to switch large bank installations in smaller sections; these are often called multistep installations. This type of control can also reduce the possibility of transient voltage magnification, as it will tend to detune the circuit by changing the capacitor energization frequency (by connecting smaller kVAr quantities into the system separately).

These types of capacitor controls are among the most effective methods of eliminating switching transients at the utility level.

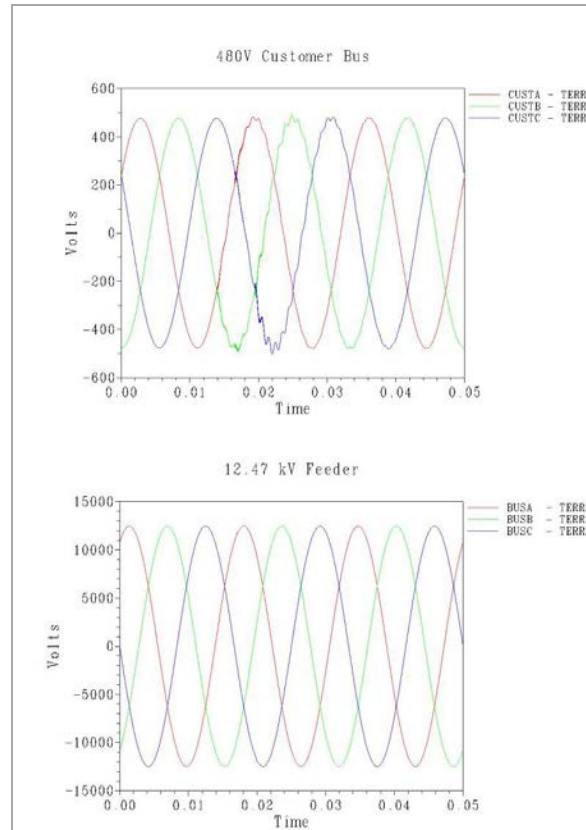

Figure 20: Capacitor Switching with Zero-Crossing Control

(3) Preinsertion Resistors

The installation of a fixed resistance in series with a switched capacitor bank will reduce the transient voltages and currents associated with the bank's energization. In order to minimize system losses, this resistance must be bypassed by short-circuit and then disconnected once the switching transient dissipates. Closing of the switch to create the bypass will produce a second transient event, but one that is not disruptive to system operation. The most ideal resistance value for a given installation is dependent upon the capacitance of the bank and the strength of the source. Figure 21 shows a preinsertion resistor configuration.

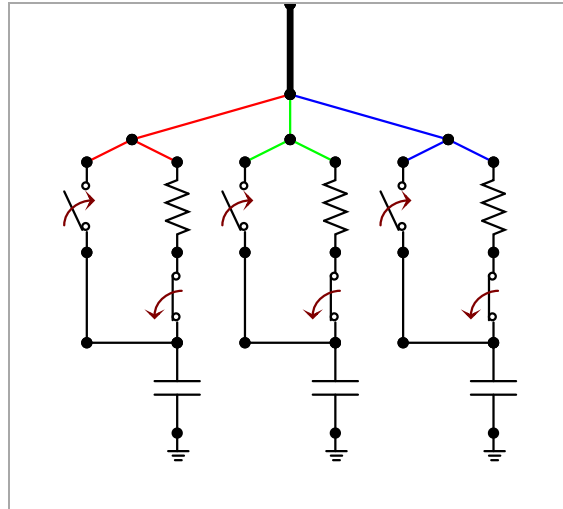

Figure 21: Preinsertion Resistor Configuration

(4) Series Inductors

Series inductances introduced at various locations in the circuit can have a number of transient-reduction effects, depending on their size and use.

- (a) Fixed Inductors on the Distribution Bank. Fixed inductors (also called reactors) installed in series with a distribution capacitor bank are capable of reducing transient current surges associated with capacitor switching. This strategy is particularly effective at reducing inrush currents caused by back-to-back switching, but does not generally provide transient voltage reduction.
- (b) Chokes. Inductors can be used as “chokes,” in series with adjustable-speed drives, to effectively “isolate” individual drives from transients. This is an effective method at consumer facilities for eliminating nuisance tripping of these sensitive devices.
- (c) Harmonic Filters. Adding inductors in series with a low-voltage, power factor-correction capacitor bank will convert the bank into a harmonic filter, which can decrease the transients on the consumer bus to acceptable levels. The bank will continue to provide power factor correction while also acting to control harmonic distortion levels within the facility and mitigate transient concerns.

(5) Surge Arresters

Low-voltage, high-energy surge arresters can be used at consumer facilities to limit overvoltages to acceptable levels. The use of *high-energy* MOVs (metal-oxide varistors) is critical in transient-limiting applications, as the possibility of voltage magnification at low-voltage

terminals leads to the possibility of very high-energy transients. The small MOVs normally found in transient voltage surge suppression equipment and power electronics are not generally robust enough to withstand a magnified transient.

4. CAPACITOR SIZING, LOCATION, AND USE

a. Light Load Conditions

The amount of capacitor kVAr needed at minimum load should be permanently connected/fixed (unswitched) to the power system. Fixed capacitor banks should be installed on the system in amounts not exceeding the minimum kVAr demand, without causing leading power factor under light conditions on the respective feeders.

Experience shows that the minimum load is wholly dependent on the type of loads being served. Industrial loads may be fairly uniform all day and all year. However, most loads are cyclical in nature and most peaks are weather-driven (either extreme hot or cold). Minimum loads for residential and small commercial loads may vary from 25% to 50% of peak. A utility system's demand on the monthly power bill does not normally show the minimum load. The demand shown on a bill for an off-peak month is still the maximum demand for that month, not minimum demand. Selecting capacitor locations for the lightest load thus requires determining the expected minimum load from the lowest peak month's historical load data.

Capacitor or kVAr needs may also be determined by tracking minimum-maximum load readings from a feeder's bus-by-bus metering records or from Supervisory Control and Data Acquisition (SCADA) loading data. The preferred methods would be in the following order of priority:

- (1) SCADA system with archived load and kW/kVAr data (this may be memory intensive),
- (2) Permanently connected meter readings of amps, kW, and kVAr or power factor, *or*
- (3) Temporarily connected metering at buses during light-load periods to measure amperes and power factor.

b. Peak Load Conditions

The capacitor selection discussed so far has dealt only with applications to correct power factor at minimum load. In order to correct power factor during heavier loading periods, it is necessary to use switched capacitors. Switching of capacitors may be done manually. However, automatic controls soon become cost-effective because of the personnel time spent manually switching and because of the additional line losses incurred if it is not done in a timely manner.

Automatic controls can track various parameters and switch the capacitor banks as needed to optimize the system p.f. The additional capacitors should be switched either as an entire bank or in steps in order to keep the p.f. from becoming significantly leading at any time. In addition, proper switching prevents both overvoltage and undesirable voltage flicker and helps the capacitors perform the task they were installed to do.

Voltage spikes or surges occur when switching capacitors because the switch usually closes when the system voltage is not at a zero-voltage crossing point. Non-zero current switching causes a capacitor to abruptly charge to the system voltage and generally creates wide-ranging overswings. This transient will take several cycles to decay and can affect industrial loads with computer-based controls. However, there are switches available now that switch only at the next zero crossing to minimize switching transients.

Capacitor bank size and location should be selected and designed in a manner that limits voltage change to 3 volts (on a 120-volt base) to eliminate customer complaints. For situations where limited switching is expected, customers on long, lightly loaded feeders may accept up to a 6-volt change.

Since switched capacitors are generally installed to supplement unswitched capacitors, they are located in the same manner as unswitched units. Results of computer load-flow studies should be used to determine the optimum sizes and locations for capacitors. Fixed capacitor installations should be designed to appropriately accommodate the system's inductive reactance expected during minimum loading. The augmenting switched capacitor installations need to be designed to appropriately accommodate the system's inductive reactance expected during peak-loading periods.

In lieu of load-flow studies and computer-calculated placement schemes, meter readings should be taken at load centers in the same manner as unswitched units, but now peak conditions should be investigated instead of minimum load conditions. Readings should be taken so that peak kVA and kW loading can be determined. Since Power Factor = kW ÷ kVA, peak load power factor can then be determined along with peak kVAr load. Knowing that

$$(kVAr)^2 = [(kVA)^2 - (kW)^2], \text{ we can calculate } kVAr = \sqrt{[(kVA)^2 - (kW)^2]}.$$

Therefore, the magnitude of switched capacitor kVAr necessary to correct the peak load power factor to unity is the difference between the kVAr of the unswitched units and peak load kVAr.

When selecting capacitors for switched units, there are certain limiting factors that have to be considered. The desired level of correction should be determined through economics: the cost of the switched capacitor installation (total annual cost) should be less than the savings derived from the installation (total annual

savings). Switching devices are expensive, but the installed cost per kVAr of a capacitor installation generally decreases as the size of the installation increases.

On rural lines especially, the standard sizes of capacitors may be somewhat large for effective switching. The smallest standard unit for primary use is now 50 kVAr, and some manufacturers do not make a unit smaller than 100 kVAr. Since switched steps of capacitors have to be multiples of standard capacitor sizes, it is impossible to correct exactly to unity or to whatever value is desired. Besides, system load is dynamic and ever-changing.

Choice of manual or automatic switching depends upon the benefits expected, the size of the capacitor bank, the amount of variation of kW and kilovar load over a typical load period, and fluctuation of voltage with load. Manual switching requires an attendant to make the necessary observations of voltage, power factor, and kilovar demand. Therefore, automatic switching would almost always be chosen, in preference to manual switching.

c. Capacitor Location

Maximum benefits are obtained by locating the capacitors as near the inductive reactance kVAr loads as possible and by matching the magnitude of the inductive reactance kVAr requirement. Practical considerations of economics and availability of a limited number of standard kVAr sizes necessitate that capacitors be clustered near load centers. Computer modeling, or rigorous evaluation of considerable load metering data, is absolutely necessary to make proper capacitor placement decisions and keep line losses as low as possible. The loss-reduction benefits possible with capacitor use can be significant enough to economically justify feeder metering or a large share of SCADA system costs.

A textbook solution assumes uniform distribution of consumers and suggests that, as the distance from the substation increases, the number of consumers per main line mile of feeder increases. To obtain maximum benefits in voltage improvement and reduction of loss on such a line, a permanently connected (fixed) capacitor bank should be located at a distance from the substation which is $\frac{1}{2}$ to $\frac{2}{3}$ of the total length of the line. This location method is used strictly as a “Rule of Thumb,” because few rural circuits contain such uniformly distributed loads.

For industrial loads, it is best to correct the power factor at the load. It is important to remember that a capacitor bank draws considerable current, so the existing source-side protective equipment needs to be checked for adequacy. In an attempt to get the maximum voltage rise by placing a bank at the end of the 3-phase line, a bank of 15-Amp or 25-Amp circuit reclosers could be loaded to the point of tripping and could create unnecessary outage problems. Correcting lagging kVAr requirements at the point of use prevents the utility’s primary line, transformer, and service lines—as well as the customer’s internal wiring—from

unnecessary losses. Moreover, when corrected on the consumer side, the utility line never sees the consumer's kVAR. Appropriate effort should be made to encourage (perhaps through rate incentives) large consumers to correct their own power factor. For more information on power factor rates and penalties, see Section 4g of this bulletin.

As previously stated, optimum benefits are derived by locating capacitors at industrial loads and at a feeder's consumer load density center for residential load. The residential load center is normally $\frac{1}{2}$ to $\frac{2}{3}$ the distance from the substation to the end of the line for uniformly loaded feeders. However, the installation of capacitors on all systems within the range specified above is not always feasible because of possible exposure of long lengths of the power line to telecommunications circuits, which may cause excessive noise interference.

Thus, the following methods are recommended for locating capacitors:

- (1) Use a computer model of your electric system and allow the computer program to place the capacitors on the system in blocks of the largest size that can be used to limit the voltage changes to 3 volts per switched bank. There are several suppliers of good engineering analysis software and many engineering consultants offer computer service. Utilities, of course, may purchase the software themselves and do their own voltage drop and capacitor placement studies. Studies should be performed in concert with the Construction Work Plan.

Computer models calculate proper capacitor placement by trying the smallest size capacitor a system uses in each line section of every feeder and calculating the total circuit losses. In this way, the computer selects the line section with the lowest net losses and then places subsequent additional capacitors in the same manner. The individual effect on feeder losses is tabulated for each capacitor placed, with each subsequent unit having less benefit. At some point, at less than unity power factor, an additional capacitor offers little additional benefit and adding more actually increases losses. Capacitors should be located so as to reduce feeder losses as much as economically practical. The first capacitor placed provides the most improvement per unit cost because it is usually a fixed capacitor and it increases power factor the most. Each subsequent unit is less economically practical.

- (2) Feeder metering at the substation or point of delivery can provide the kW/kVAR information that is needed for both kVAR correction and engineering analysis. Additional kVAR information is available using new technology kVAR or power factor meters attached to hot sticks. No electrical connections to the line are necessary. Placing the meter in contact with the primary wires will allow the necessary measurements to be recorded. Power factor and phase current data can be used to calculate kVA, kW, and kVAR

flow. Example 7 that follows assumes that the system operator is using the “Rule of Thumb” method for locating an acceptable site for a capacitor bank. This means that the system operator travels $\frac{1}{2}$ to $\frac{2}{3}$ of the way out the line from the substation and conducts the sequence of measurements and determinations suggested in Example 7.

EXAMPLE 7. At a given point on a 12.5/7.2-kV feeder, the following is measured:

Currents: 25, 12, and 40 amperes (A, B, and C Phases, respectively)

Average Power Factor: 0.85

What do you know about the system at this point?

CALCULATIONS:

$$\text{Average Current} = (25 + 12 + 40) \div 3 = 25.7 \text{ Amperes}$$

Circuit Balance	=	A Phase	Good Balance
		B Phase	13 Amps low
		C Phase	13 Amps high

$$\begin{aligned} \text{kVA} &= [(3) \times (\text{Average Current}) \times (\text{Voltage} \\ &\quad \text{(line-to-neutral)})] \div 1,000 \\ &= [(3) \times (25.7) \times (7,200)] \div 1,000 \\ &= 554 \text{ kVA} \end{aligned}$$

$$\text{Phase Angle} = \text{Arccosine} (\text{power factor})$$

$$\text{Phase Angle} = \text{Arccosine} (0.85) = 31.8 \text{ degrees}$$

$$\text{kW} = (\text{kVA}) \times (\text{power factor}) = (554) \times (0.85) = 471 \text{ kW}$$

$$\begin{aligned} \text{kVAr} &= (\text{kVA}) \times \text{Sine} (\text{phase angle}) \\ &= (\text{kVA}) \times \text{Sine} [(\text{Arccosine} (\text{power factor}))] \\ &= (554) \times \text{Sine} (31.8 \text{ degrees}) \\ &= 292 \text{ kVAr} \end{aligned}$$

Figure 22 shows a power triangle for this example.

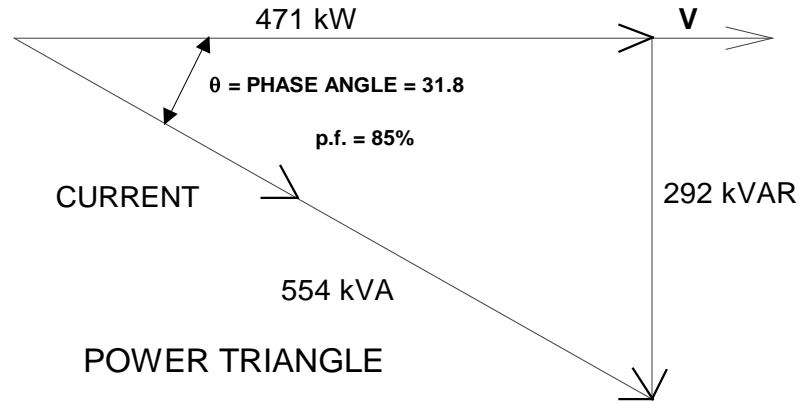

Figure 22: Power Triangle for Example 7

So with a few field measurements and an inexpensive scientific calculator, we know that almost 300 kVAr flows past this point. If capacitors were to be placed here, then 300 kVAr (three 100-kVAr units) of capacitors located here (or beyond) would eliminate all lagging kVAr flow under these load conditions.

The addition of 300 kVAr of capacitors would change the kVAr flow from (292) – (300) = –8 kVAr. The new phase angle is:

$$\begin{aligned} \text{New Phase Angle} &= \text{ARC TAN (kVAr/kW)} \\ &= \text{ARC TAN } (-8/471) \\ &= -0.973 \text{ degrees (current leading)} \end{aligned}$$

$$\begin{aligned} \text{New kVA} &= (\text{kW}) \times \text{COS (New Phase angle)} \\ &= (471) \times (0.999) \\ &= 471 \text{ kVA} \end{aligned}$$

$$\begin{aligned} \text{New Average Current} &= (\text{kVA}/3) \div (\text{kV}) \\ &= (471/3) \div (7.2) \\ &= 21.8 \text{ Amperes} \end{aligned}$$

If you knew that the system impedance at this point (or near this point) was $14.5 + j 15.3$ ohms, the voltage rise here from the 300-kVAr, 3-phase capacitor bank would be:

$$\begin{aligned} \text{Voltage Rise} &= (\text{Primary Capacitor Current}) \times (\text{Inductive Reactance}) \\ &= [(100 \text{ kVAr/Phase}) / (7.2 \text{ kV})] \times (15.3 \text{ ohms Reactive}) \\ &= 212.5 \text{ volts at 7,200 volts, } \textit{or} \\ &= (212.5) \div (7,200/120) \\ &= 3.54 \text{ volts on 120-volt base} \end{aligned}$$

So by relieving the electric system of 292 lagging kVAr at this point, you have lowered the load from 554 to 471 kVA, reduced the average current from 25.7 to 21.8 amps, and gained 3.5 volts at this point and beyond.

d. Three-Phase Capacitor Banks

Capacitors to be installed on 3-phase circuits should be installed in equal kVAr amounts per phase and not in proportion to the total connected transformer capacity on each phase. System loads should already be balanced within 20% (at peak load). In general, capacitors should not be installed on single-phase extensions of the main three-phase feeder. However, if it is absolutely necessary to install single-phase capacitor banks on a 3-phase line, they should still be equally sized per phase and located close to each other so as to appear to be a Y-connected bank of capacitors.

This balance needs to be maintained to:

1. Minimize power factor phase unbalance, which translates into unbalanced voltages and unbalanced phase angles for 3-phase loads; and
2. Minimize the effect of certain harmonic currents that would otherwise be produced and flow in the neutral conductor where it could cause interference in nearby telecommunications circuits. Power factor unbalance causes more aggravating noise induction problems than does load unbalance, and these noise problems occur at higher and more troublesome frequencies.

As noted in Section 3a of this bulletin, when one phase of a capacitor bank is out of service, take the entire bank out of service. Capacitors should be inspected regularly, at least before and after peak seasons.

e. Capacitor Installation Drawings

Installation drawings for shunt capacitors on 3-phase lines are provided in RUS Bulletin 1728F-803, "Specifications and Drawings for 24.9/14.4 kV Line Construction," and RUS Bulletin 50-3, "Specifications and Drawings for 12.5/7.2 kV Line Construction." Only professional engineers should develop major variations from these RUS standards and such variations should be approved, in writing, by RUS.

For convenience, the standard drawing VY3.3, 3-Phase Capacitor Bank, is provided in Figure 23.

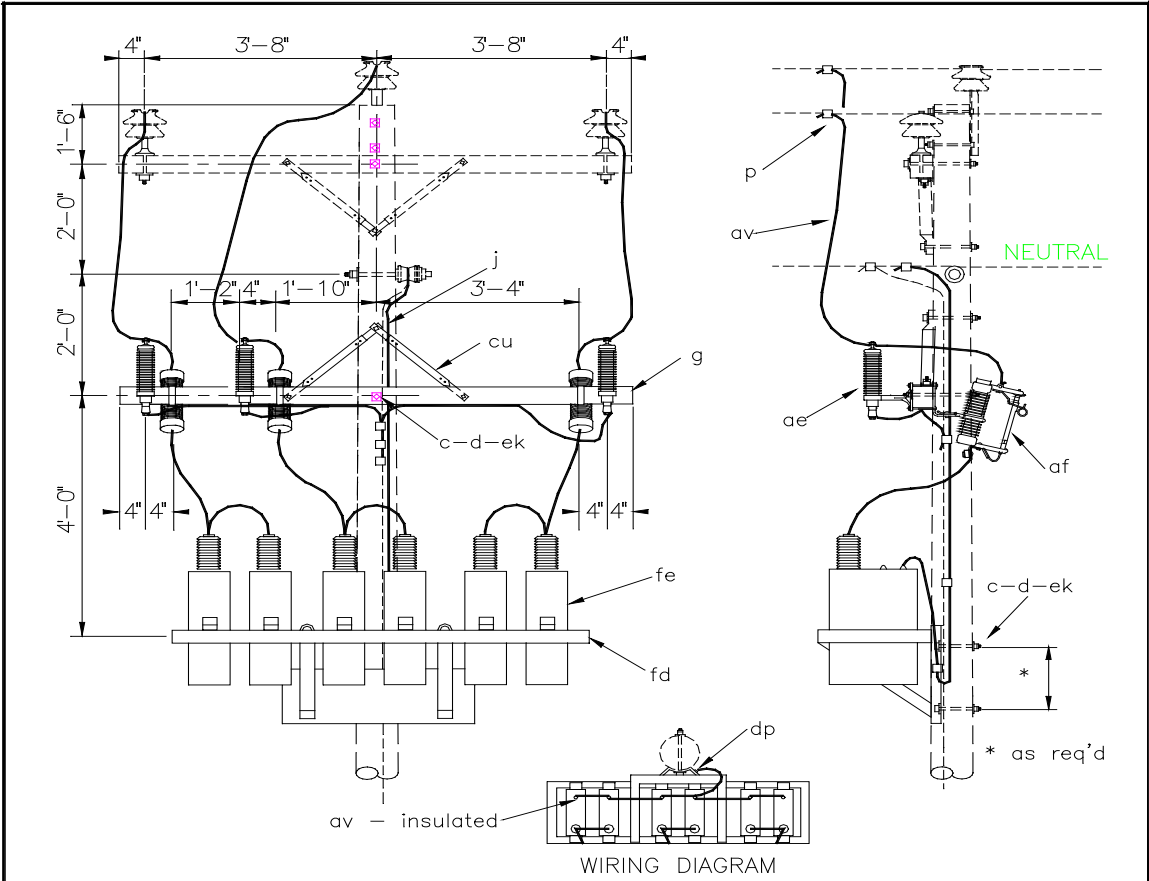

- NOTE:
 1. Specify insulating caps for primary terminal bushings.
 2. For two-phase assemblies, omit capacitors and other material on center phase; designate assembly as "VY3.2".

ITEM	QTY	MATERIAL	ITEM	QTY	MATERIAL
c	3	Bolt, machine, 5/8" x req'd length	av		Jumpers, bare, stranded, as req'd
d	4	Washer, square, 2 1/4"	av		Jumpers, insulated, as req'd
g	1	Crossarm, 3 5/8" X 4 5/8" X 8-0"	cu	2	Brace, 28"
i	2	Bolt, carriage, 3/8" x 4 1/2"	dp	1	Clamp, ground wire
j	1	Screw, lag, 1/2" x 4"	ek	5	Locknuts
p		Connectors, as req'd	fc		Capacitor, shunt, 24.9/14.4 kV (specify number and kVAR)
p		Connectors, compression, as req'd	fd	1	Hanger, capacitor
ae	3	Arrester, surge (18 kV)			
af	3	Cutout, dist., loadbreak, (27 kV)			

THREE PHASE CAPACITOR BANK

DEC 1998	3 - PHASE PRIMARY	
RUS	24.9/14.4 kV	VY3.3

Figure 23: Three-Phase Capacitor Drawing

f. Automatic Capacitor Switching

Additional material and equipment will be required when automatic capacitor switching is to be installed. In addition to the capacitors and protective equipment, a switched capacitor bank requires a switching device, control equipment, and a control power source.

The control equipment for automatic switching consists of a master element, a time-delay device, and auxiliary devices such as an auto-manual switch and a close-trip switch. Some controls provide dual controls for summer/winter conditions or for dual conditions such as thermal/voltage. The master element is selected to suit the conditions of the system on which the control unit is to be used. Such stimuli as voltage, current, temperature, kilovar, power factor, or timing (or a combination thereof) may be used to actuate master elements. It is common to switch all three phases using one current sensor, so the designer should verify that all three phases have similar amounts and types of load. In brief, the various types of master element control are as follows:

- (1) Voltage. Responds to objectionable voltage changes that occur with varying loads. One type of master element voltage control is essentially a contact-making voltmeter, which has a range of adjustment from 90 to 110% and a bandwidth adjustable from 3 to 7½%. Another type of master element voltage control incorporates a resistor inserted in series with a voltage-regulating relay, which enables the master element to sense a lower voltage during high load periods. (This type of master element sensing has to be coordinated with regulators for proper operation). Most controls allow dual-sensing actuation or biasing, to allow control by temperature with voltage override so capacitors can be switched in during either high-temperature or low-voltage times.
- (2) Current. Responds to changes in load current by means of a current-sensitive relay. This means of control may be used on systems where the voltage is well-regulated and the power factor of the load remains substantially constant with variation in kW loading, or on systems where the power factor of the circuit varies in a predictable manner with variation in kW loading. (This is useful for recreational, seasonal, irrigation, or oil well pump-type loads when such loads constitute the bulk of the feeder load.) Current sensing is usually located near the primary conductors inside the insulators supporting the conductors. Low-voltage current leads are neatly and safely trained down the supporting structure and connected to the master control.
- (3) Temperature. Responds to local air temperature for tracking such temperature-sensitive loads as ac and electric heat. Controls include both wide-range and narrow-range settings. Wide-range controls can be set to switch capacitors “ON” and “OFF” for various temperature

ranges, for example, “ON” between 85 and 90 degrees Fahrenheit and “OFF” for temperatures between 75 and 80 degrees Fahrenheit. This feature allows a second tier of capacitors to act as fixed units during a long spell of hot or cold weather. Other capacitor banks can be controlled with narrow-range controls and be set to turn “ON” for temperatures between 90 and 92 degrees Fahrenheit and to turn “OFF” for temperatures between 85 and 88 degrees Fahrenheit, to handle system peak loads.

- (4) Kilovar. Responds to inductive loading and is used where load voltage is regulated, and load power factor varies in an unpredictable manner with variation in kilowatt loading. KVAR-type controls use an induction-directional or solid-state relay for single-phase indication. KVAR control has been useful for improving system power factor in situations where one large industrial customer is served, and the customer does not provide its own power factor correction.
- (5) Power Factor. Responds to changes in power factor and is similar to kVAR control in that it uses an induction-directional or solid-state relay with a desensitizing adjustment to prevent hunting at light loads. The desensitizing adjustment is needed to account for the possible occurrence of the power factor bandwidth being less than the change in sensing caused by switching the capacitor.
- (6) Time Switching. Responds by using a simple clock device to switch capacitors at some predetermined time. It is primarily used where the load characteristics are predictable and reasonably constant, as with industrial loads. Desirable added features are weekend and holiday blocking. This can be a low-cost method. It is also recommended that the clock be capable of remaining accurate in case of a power outage.
- (7) Centralized Control. In addition to using localized controls and conditions to switch capacitor banks, a centralized master element control can be used to switch multiple capacitor banks installed across the system based on global system conditions. One drawback to this type of control method is that communications are required with the capacitor control. Due to the low bandwidth requirements, though, the communications channel can be basic, such as radio or cellular. One-way communications are all that are required, but if two-way communications are employed, local status information can be brought back as well. The primary advantage of a centralized control scheme is that switching logic can be based on more than just local conditions. Typically, a system operator or an automation software system determines when one or more capacitor banks should be switched on to support the system, possibly not just the distribution system but the transmission system, regardless of the local conditions present at the capacitor installation. Local overrides are typically programmed into the capacitor control to prevent switching from a centralized command if

that switching would cause local conditions to reach unacceptable levels, such as an overvoltage condition.

g. Leading Power Factor

If the kVAr load on the system becomes less than the kVAr rating of the installed capacitors, a leading power factor will occur. Leading system p.f. can, in severe instances, cause generators to become unstable. For example, if a distribution circuit peaking at 4,000 kW were to run leading such that kVA was ½% more than kW, the leading p.f. would be 0.995 and the leading kVAr would be 400. A leading power factor will cause the same losses as a lagging power factor of the same magnitude. If the power factor does go excessively leading, a system ends up spending money unnecessarily for capacitors (to reduce system losses) because it still incurs losses anyway. The solution is to either reduce the capacitors installed or switch them off when not needed.

Because substation power transformers have predominately inductive (lagging) reactance, a slight distribution system leading power factor translates into a power factor closer to unity on the transmission system. In this case, the leading power factor helps the transmission system.

h. Power Factor Penalty Rates

Most distribution utilities have power factor clauses in their commercial and industrial retail rates that strongly encourage the customer to maintain a 90–95% power factor; otherwise, the customer has to pay a penalty charge. Traditionally, these power factor penalty clauses were added into retail rates because the utility's purchased power rates included similar penalties. Lower power factors usually cause an increased billing demand by the ratio of the target p.f. divided by the metered p.f., usually on peak.

A traditional method of applying a power factor penalty adjusts (raises) the billing demand in proportion to the metered power factor deviation from the desired power factor. This billing demand adjustment is expressed as:

$$\text{Billing Demand} = (\text{Metered Demand}) \times (\text{Target p.f.} \div \text{Measured p.f.})$$

For example, customers that have monthly bills with a metered p.f. of 0.83 and a target p.f. of 0.95 (minimum allowed by the utility in this example), the billing demand would be multiplied by $0.95 \div 0.83 = 1.145$. This 14.5% increase in billing demand should alert customers and encourage them to improve their power factors.

You may help persuade consumers to correct their own power factor by pointing out to them that capacitors help their system in the following ways:

- (1) Reduce their power factor penalties, if applicable;
- (2) Improve their in-plant voltage levels;
- (3) Reduce their in-plant line and transformer losses; and
- (4) Release (reclaim) substation, transformer, switchboard, and conductor capacity on their system.

A few utilities offer reduced billing demand if the actual power factor exceeds the desired power factor.

More information about secondary capacitors and power factor correction for induction motors is included in Section 6 of this bulletin.

i. Capacitor Fusing

Fuse protection is necessary for each shunt capacitor installation, mainly to disconnect a faulted capacitor from the line before the capacitor causes other current protective devices to operate. Capacitor fuse protection has to be coordinated with any line sectionalizing devices that will be operated on the feeder. Fuses should be designed to blow before the capacitor case ruptures in order to prevent personal injury, damage to adjacent equipment, or capacitor dielectric fluid leaks.

Shunt capacitors are designed to operate temporarily at 135% of their rated kVAr. From Section 6a of this bulletin, Equation 11, we know that a 16.2% overvoltage gives 135% of kVAr. This 35% above rated tolerance is to allow for:

- (1) Additional kVAr (reactive power) that could be present as a result of operating the capacitors at voltages above their nameplate fundamental frequency voltage,
- (2) Additional kVAr that could be generated as a result of slightly higher than normal harmonic voltages that could be present along with the fundamental frequency voltage, and
- (3) Additional kVAr that could be present as a result of the capacitor's actual kVAr being on the high side of allowable manufacturing tolerances.

Capacitor current protection devices should have a nominal rating of 135% to 140% of the capacitor line current.

Capacitor units are not normally fused individually, but by phase in a bank of one or more capacitors per phase. Banks should always contain the same amount of kVAr in each phase. Capacitor fusing is normally designed to operate at 120% to 135% of the capacitor's nameplate current rating, although such fusing is occasionally derated to no less than 108% for multiple units per phase.

In general, a fuse link should melt in 5 minutes at 150% to 300% of rated current. Fuses for small capacitors should have at least a 5-ampere rating to minimize the likelihood of fuse failure due to lightning or transient surges. In high lightning areas, fuses should be 15 amperes or larger, but no greater than 140% of the

capacitor's nameplate current rating. The choice of fuse rating for a capacitor installation should always be based on a particular fuse's time-current characteristics. This individual design attention is needed because of the wide variation in fuse time-current characteristics and the different types and brands of fuses available.

The following table detailing Edison Electric Institute/National Electrical Manufacturers Association (EEI/NEMA) Type T and Type K fuse links for protecting capacitors was created from Table 15A3 on page 102 of *Electrical Distribution-System Protection, 3rd Edition*, Bulletin 90020, Cooper Power Systems.

Table 3: Capacitor Fusing Table

3- ϕ kVAr	Full Load Amps	12,470/7,200 Gnd Y	3- ϕ kVAr	Full Load Amps	24,900/14,400 Gnd Y
150	6.9	8T			
300	13.9	15T	300	6.9	8T
450	20.8	20T	450	10.4	10T
600	27.8	25T	600	13.9	15T
900	41.7	40T	900	20.8	20T

If lightning causes excessive fuse blowing but there is no capacitor damage, fuses should be replaced with the next larger size.

j. Safety Precautions

Capacitors require special precautions when they are taken out of service for repair or maintenance. Like a battery, a capacitor may retain a charge for an indefinite time after being disconnected; the capacitor charge can be quite hazardous to an unsuspecting individual who encounters the charge. Generally, discharge resistors are manufactured into each capacitor unit to help dissipate charge when the unit is out of service. The discharging resistors should reduce the terminal voltage of a capacitor unit to 50 volts or less in one minute for units rated at 600 volts or less, and in five minutes for units rated higher than 600 volts.

(1) In Situ Repair

Added precautions should be taken when working with delta and nongrounded, wye-connected capacitors. A hazardous voltage may be present on a capacitor even when the phase conductor to which the capacitor is connected is open-circuited for work. Line voltage can feed back through the capacitor (via the capacitor's common connection) with capacitors connected to other phase conductors that are still energized. This is why it is important for line crews to always check phase conductors for the presence of voltage.

It is generally good practice before working on a capacitor bank to completely de-energize the bank and disconnect all line conductors from all terminals. It is not good practice to rely on a capacitor's internal discharging resistors to reduce the terminal voltage to a safe value after being disconnected from a power line. After disconnecting a capacitor and waiting for the discharging resistors to bleed voltage down, it is best to then short-circuit the capacitor terminals and connect the shorted terminals and the cases to ground.

(2) Out of Service Repair/Storage

When capacitors are removed from their racks, after waiting several minutes (during which time the discharging resistors should have reduced the capacitor terminal voltage practically to zero) the terminals should be simultaneously short-circuited and solidly connected to their cases. These connections should be left intact, because capacitors tend to accumulate a residual charge (even when not connected to a power source) if not short-circuited. Number 6 copper wire can be used to make the capacitor terminal-to-terminal-to-case shorting connections. The connection should not be removed until the unit is reinstalled.

(3) Load Breaking Considerations

It is important to note that a capacitor bank can be a formidable load as the kVAr size used increases. A 600-kVAr bank at 7,200 V draws about 28 Amps. A bank drawing this much current cannot be "unloaded" without the use of load-break cutouts. Therefore, it is recommended that load-break cutouts be used on capacitor banks for continuity of service and safety during maintenance procedures.

5 POWER SUPPLY CONSIDERATIONS

a. Capacitor Effects on Substations

In most cases, greatest efficiency of shunt capacitor use is achieved by placing capacitors out on the distribution line. In some cases, capacitors may have to be installed inside substations. This may be the case if the substation is located near a large industrial load, or the substation feeders are all underground where capacitors are more difficult and expensive to install.

The voltage improvement at a substation distribution bus with the substation transformer carrying full load—due to a shunt-connected capacitor installation at that location—may be calculated with the following formula:

$$\% \text{ Voltage Improvement} = \frac{(ckVA_r) \times (Z)}{tkVA}$$

Equation 10: Percent Voltage Improvement at Substation

Where:

Z = Percent transformer impedance

tkVA = Transformer kVA rating

ckVA_r = Total capacitor kVA_r

Voltage rise at a substation is predominantly controlled by the reactance component of the transformer impedance. However, the impedance of most substation transformers is practically equal to the reactance. Thus, the percent impedance value that is provided on a substation transformer nameplate may be used to calculate voltage rise without appreciable error. If the transformer reactance is known, using the known value of reactance in lieu of total impedance will yield precise results.

The total voltage improvement brought about by the installation of shunt capacitors at a substation is the sum of the voltage improvements of all components of the system. When there are no regulators installed at the substation, the voltage improvement in the substation transformers is added to the voltage improvement on the distribution line to determine the total effect on the distribution line voltage. The voltage improvement due to the application of capacitors at a substation is neutralized at the distribution regulator within the operating range of the regulators.

The voltage rise on the distribution line or substation transformers due to capacitors connected away from the substation out on the system is *not* dependent on the system load. The capacitor's leading current flows through the lagging system reactance and creates the voltage rise. The benefits from this rise on a typical distribution system are usually less important than those from the reduction in system energy losses and the release (reclaiming) of kVA capacity for additional useful load.

b. Effects of Distribution Capacitors on Transmission Lines

In addition to the rise in feeder voltage due to a capacitor installation, the transmission circuit (as well as other substation transformers between the generating station and the capacitor location) will undergo a similar voltage rise. Since the electrical characteristics of these parts of the system vary so widely with construction practices among power suppliers, their voltage rise cannot be readily reduced to chart form. But, when you know the total system impedance, you can easily calculate the voltage rise of any capacitor at any point on the system using the formulas and methods discussed previously for capacitors out on the distribution system.

c. Increase in Substation Capacity

Since an increase in power factor reduces the current drawn by a given load, a capacitor installation reduces the kVA demand for that load. The decrease in load demand due to a capacitor installation corresponds to released (reclaimed) substation capacity. This released capacity is of particular value when the substation load approaches the substation design capability. Capacitors may also relieve existing overloaded conditions.

6 CAPACITORS FOR INDUCTION MOTORS

a. Switched Shunt Capacitor Banks

Capacitors installed on the primary circuit are, in some cases, limited to those required for the correction of the power factor of the system without considering the requirements of large inductive loads. But capacitors can be operated at voltages above their nameplate ratings for very short times of no more than a few minutes, effectively increasing their available kVAr.

The most common use of this short-term capacitor overvoltage capability is for starting large motors with reduced voltage flicker. For this purpose, a wye-connected capacitor bank is reconnected into a delta-connected switched capacitor configuration which overvoltages capacitors in each delta leg by 1.732 times normal voltage (placing line-to-line voltage on a line-to-neutral unit). This overvoltage raises the effective kVAr to three times the capacitor's normal rating because:

$$\text{kVAr} = [V^2 \times (2\pi f) \times (C)] \div 1,000$$

Equation 11: kVAr

Where:

V = Rated rms voltage

π = 3.1416

f = Frequency in hertz = 60 Hz for U.S. power systems

C = Capacitance in farads

As switching methods become complex, motors may be controlled by programmable logic controllers (PLC), which are small computers with rudimentary programming code used in manufacturing control systems. When a large motor start button is pressed:

- (1) The PLC closes the primary switches on the capacitor bank and monitors capacitor inrush current or the system voltage to get full use of the capacitors, then
- (2) The PLC closes the motor contactor and monitors the motor starting current as the motor current falls from its starting high to near its running level, and

- (3) The PLC finally opens the capacitor primary switches to remove the starting capacitor bank from the circuit. All this happens within 10 to 20 seconds and allows a large motor to start with less impact on the distribution feeder. Considerable coordination with the customer is required as the control is installed and tested.

b. Secondary Capacitors

Secondary capacitors are available for installation at a motor at somewhat higher costs than primary units. However, the benefits of the capacitor at the motor in decreasing starting and running current and the attendant losses are extended to the secondary and service wiring, as well as the supply transformer and the balance of the distribution system.

The motor starter is used to switch on the capacitor, which is wired directly to the large motor. The resulting load then behaves like a high power-factor load on the system.

Certain limitations on the size of capacitor installations for various motor sizes and rotational speeds have to be imposed to avoid the possibility of self-excitation of the motor with its attendant problems. The maximum size of capacitor that can be used on an induction motor is one that is not large enough to augment magnetization current of the motor at any point on its starting and running curve. If this limitation is exceeded, the motor may run at a subsynchronous speed and draw excessive current, which may damage the windings.

If the power source is disconnected momentarily, the motor will operate as an induction generator while it is coasting. Reconnection of the motor to the supply will have the same effect as closing the main switch on a generator that is not synchronized to the supply line.

Motor damage is possible when a motor is disconnected from its supply line. At the instant the motor is disconnected, current continues to flow in the circuit consisting of the motor winding inductance and the parallel connected capacitor. Resonance may occur at some point on the motor speed curve as the motor slows down. If this resonance occurs, voltage will rise on the motor windings and only the "Q" of the tuned circuit will limit the rise. The damping effect of the line resistance is no longer available to limit this voltage and the motor insulation may be damaged.

Capacitor manufacturers can provide up-to-date information on suggested capacitor sizes for various motor sizes and loads. Appendix B is a listing of the maximum permissible capacitor rating that can be used with various motors so that no self-excitation voltages will be produced. These values do not necessarily correspond to standard capacitor ratings, in which case, the next lower rating should be used.

When capacitors are connected to motor terminals, the current flowing in the supply circuit is reduced. When the capacitors are connected on the motor side of an overload protective device, this device will no longer provide adequate protection if the protection device has been selected on the basis of the uncorrected full-load current. For effective protection, either the circuit breaker relay needs to be adjusted, or a new fuse needs to be installed. The new fuse should have a rating that allows it to operate at a lower current consistent with the reduced line current.

A 1-kVAr secondary capacitor at the load is equivalent to approximately a 1.04-kVAr capacitor installed on the primary, from the standpoint of reduction of losses in the transformer and on the service side of the installation. Secondary capacitors provide additional voltage rise through the service transformers and facility wiring. With this type of capacitor application, where the load varies so widely, the secondary capacitor, which is switched with the load, is a practical and economical solution.

c. Series Primary Capacitors

(1) Applications and Problems

Series-connected primary capacitors cause a voltage rise quite different from shunt-connected capacitors. Shunt-connected capacitors cause voltage rise when the leading current (I_C) they draw from the power source flows through the lagging impedance (X_L) of line conductors ($I_C \times X_L$). Conversely, series-connected capacitors cause a voltage rise when the lagging load current (I_L) drawn by the inductive system impedance sources flow through the leading impedance (X_C) of the series-connected capacitors ($I_L \times X_C$). See Figure 24.

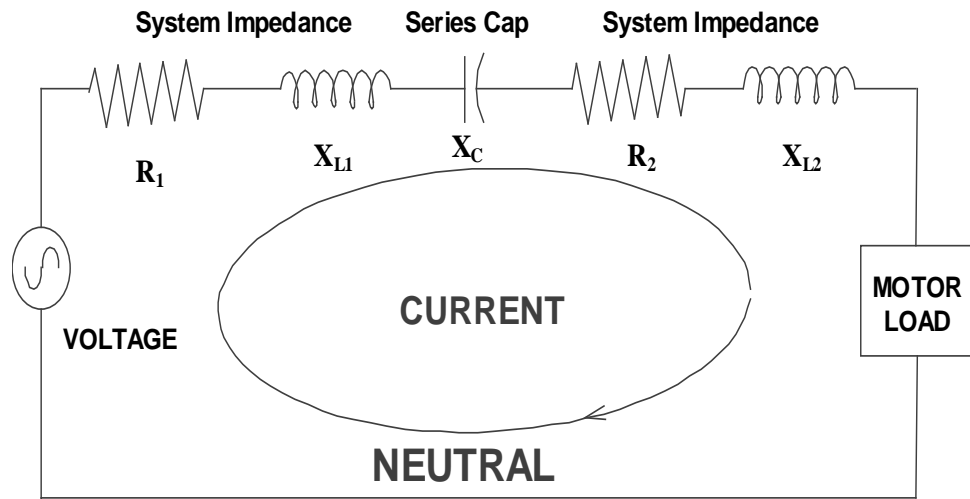

Figure 24: Series Capacitor Circuit

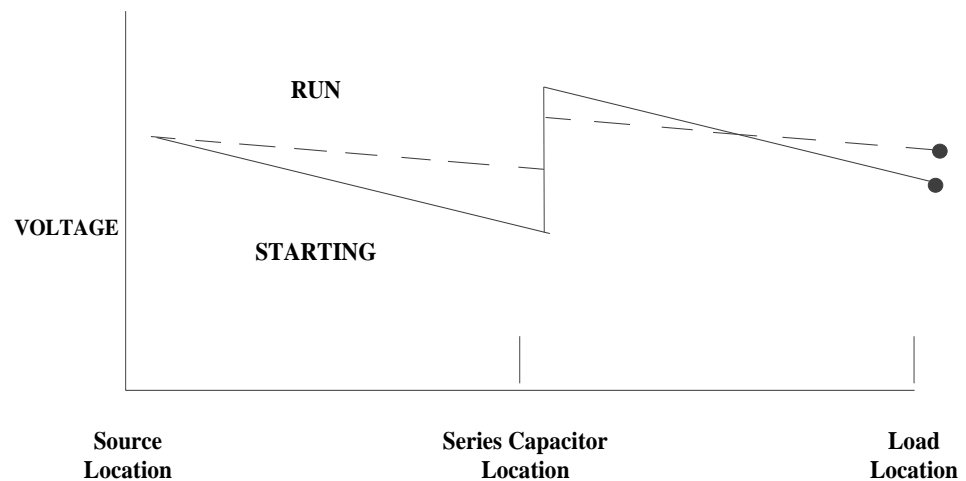

Figure 25: Motor Starting with Series Capacitor

This rise through the series-connected capacitor is particularly useful in canceling voltage dips caused by large motors during starting, as shown in Figure 25.

A properly sized series capacitor could cancel the entire voltage drop of motor starting current and even add a rise at the lower running current levels.

It sounds too good to be true. If series-connected capacitors do all this, then why are most utilities not using them? Some utilities do use series capacitors; however, there are other inherent problems which usually outweigh the benefits.

The biggest problem is lightning. Since neither bushing of the capacitor is connected to ground, both ends have to be effectively protected with lightning arresters. And because lightning current traveling down the

phase conductor would pass through the capacitor and damage it, some current bypass method is also needed. Some utilities have tried installing lightning arresters across the capacitor with limited success. Some utilities have developed solid-state switching controls that either:

- a) Switch the series capacitor into the circuit when a predetermined current level is sensed; or
- b) Bypass the series capacitor when surge current is sensed.

Permanent series capacitor installations have proven to be impractical because of the considerable design problems. However, utilities have had some limited success with temporary series capacitor installations and have used them until major system improvements allow their removal.

Series capacitors are included here to provide a complete discussion of distribution capacitors.

(2) Sizing Series Capacitors

In order to determine the size of a series-connected capacitor to install on a system, the designer needs to know the system impedance at various points along the distribution feeder. A computerized fault current study can be used to provide the necessary impedance information. The magnitude of the feeder load current and the feeder's power factor also have to be known or calculated. The entire voltage rise occurs across a series capacitor. A decision has to first be made to determine at what point on the system the lumped voltage rise is needed and whether nearby customers will be able to tolerate the resulting voltage fluctuations. Knowing the value of the voltage drop that needs to be cancelled and the prevailing feeder load current, the capacitive reactance necessary to accomplish the improvement can be calculated as follows:

The voltage drop through a feeder without the series capacitor connected is approximately:

$$V.D. = I_X \times R_X \times (\text{COS } \theta) + I_X \times X_L \times (\text{SIN } \theta)$$

Equation 12: Voltage Drop

Where:

- R_X = Feeder Resistance
- X_L = Feeder Reactance
- I_X = Feeder Current
- θ = Feeder Power Factor Angle

With a series capacitor installed, the voltage drop becomes:

$$V.D. = I_X \times R_X \times (\text{COS } \theta) + I_X \times (X_L - X_C) \times (\text{SIN } \theta)$$

$$V.D. = I_X \times R_X \times (\cos \theta), \text{ when } X_L = X_C$$

Equation 13: Voltage Drop with Series Capacitor

Where:

R_X = Feeder Resistance

X_L = Feeder Reactance

X_C = Series Capacitor's Reactance

I_X = Feeder Current

θ = Feeder Power Factor Angle

To avoid excessive voltage rise during normal load conditions and to avoid flicker during motor starts and stops, the capacitive reactance should be smaller than the feeder's inductive reactance. If the load power factor is near 100%, there will not be much capacitive rise. If the load power factor is leading, there will be a voltage *drop*. Voltage increases with series capacitors because the lagging load current produces a voltage rise through the leading capacitive reactance of the series capacitor. Voltage increases with shunt capacitors because the leading capacitive current drawn through the system by a shunt capacitor produces a voltage rise through the lagging conductor reactance.

$$X_C = 1,000,000 \div (2\pi fC)$$

Where:

π = 3.1416,

f = Frequency in hertz

C = Capacitance in microfarads

Solving for capacitance, we obtain:

$$C = 1,000,000 \div (2\pi fX_C)$$

And capacitor kVAr is equal to:

$$\text{kVAr} = [(2\pi fC) \times V^2] \div 1,000$$

Where:

V = rated rms voltage of Capacitor units

7 REFERENCES

40 CFR Part 761, *Polychlorinated Biphenyls (PCBs) Manufacturing, Processing, Distribution in Commerce, and Use Prohibitions*.

Capacitor Switching Transients: A Best Practices Guide. TVPPA R&D Project CS-1, 2011.

Dai, R., R. Walling, and L. Freeman, *Conservation Voltage Reduction (CVR) Evaluation: Testing, Methods, and Results*, DSTAR Project 13-7 Final Report, 2013.

Electrical Distribution-System Protection: A Textbook and Practical Reference on Overcurrent and Overvoltage Fundamentals, Protective Equipment and Applications, 3rd Edition, Bulletin 90020, Cooper Power Systems, 1990.

IEEE Standard 18-2012, *Standard for Shunt Power Capacitors*, 2012.

IEEE Standard 1036-2012, *Guide for Application of Shunt Power Capacitors*, 2012.

IEEE Standard C37.99-2012, *Guide for the Protection of Shunt Capacitor Banks*, 2012.

Power Factor Correction: A Guide for the Plant Engineer. Technical Publication No. SA02607001E/Z15663. Eaton. August 2014.

RUS Bulletin 1728F-803, *Specifications and Drawings for 24.9/14.4 kV Line Construction*, December 1998.

RUS Bulletin 1728F-804, *Specifications and Drawings for 12.47/7.2-kV Line Construction*, October 2005.

APPENDIX A POWER FACTOR TABLE

The following table can be used to calculate power factor using real power (kWh) and reactive power (kVArh) data.

Table A1: Power Factors

Power Factor	Third Decimal Accuracy Power Factor (Add to Left-Most Column Power Factor Result)									
	0.000	0.001	0.002	0.003	0.004	0.005	0.006	0.007	0.008	0.009
	Tangents Corresponding to Power Factor Angle									
1.00	0.000									
0.99	0.142	0.135	0.127	0.119	0.110	0.100	0.090	0.078	0.063	0.045
0.98	0.203	0.198	0.192	0.187	0.181	0.175	0.169	0.163	0.156	0.150
0.97	0.251	0.246	0.242	0.237	0.233	0.228	0.223	0.218	0.213	0.208
0.96	0.292	0.288	0.284	0.280	0.276	0.272	0.268	0.263	0.259	0.255
0.95	0.329	0.325	0.322	0.318	0.314	0.311	0.307	0.303	0.299	0.296
0.94	0.363	0.360	0.356	0.353	0.350	0.346	0.343	0.339	0.336	0.332
0.93	0.395	0.392	0.389	0.386	0.383	0.379	0.376	0.373	0.370	0.366
0.92	0.426	0.423	0.420	0.417	0.414	0.411	0.408	0.405	0.401	0.398
0.91	0.456	0.453	0.450	0.447	0.444	0.441	0.438	0.435	0.432	0.429
0.90	0.484	0.481	0.479	0.476	0.473	0.470	0.467	0.464	0.461	0.459
0.89	0.512	0.510	0.507	0.504	0.501	0.498	0.496	0.493	0.490	0.487
0.88	0.540	0.537	0.534	0.532	0.529	0.526	0.523	0.521	0.518	0.515
0.87	0.567	0.564	0.561	0.559	0.556	0.553	0.551	0.548	0.545	0.542
0.86	0.593	0.591	0.588	0.585	0.583	0.580	0.577	0.575	0.572	0.569
0.85	0.620	0.617	0.614	0.612	0.609	0.607	0.604	0.601	0.599	0.596
0.84	0.646	0.643	0.641	0.638	0.635	0.633	0.630	0.628	0.625	0.622
0.83	0.672	0.669	0.667	0.664	0.662	0.659	0.656	0.654	0.651	0.649
0.82	0.698	0.695	0.693	0.690	0.688	0.685	0.682	0.680	0.677	0.675
0.81	0.724	0.721	0.719	0.716	0.714	0.711	0.708	0.706	0.703	0.701
0.80	0.750	0.747	0.745	0.742	0.740	0.737	0.734	0.732	0.729	0.727
0.79	0.776	0.773	0.771	0.768	0.766	0.763	0.760	0.758	0.755	0.753
0.78	0.802	0.800	0.797	0.794	0.792	0.789	0.787	0.784	0.781	0.779
0.77	0.829	0.826	0.823	0.821	0.818	0.815	0.813	0.810	0.808	0.805
0.76	0.855	0.852	0.850	0.847	0.845	0.842	0.839	0.837	0.834	0.831
0.75	0.882	0.879	0.877	0.874	0.871	0.869	0.866	0.863	0.860	0.858
0.74	0.909	0.906	0.904	0.901	0.898	0.895	0.893	0.890	0.887	0.885
0.73	0.936	0.933	0.931	0.928	0.925	0.923	0.920	0.917	0.914	0.912
0.72	0.964	0.961	0.958	0.956	0.953	0.950	0.947	0.944	0.942	0.939
0.71	0.992	0.989	0.986	0.983	0.981	0.978	0.975	0.972	0.969	0.967
0.70	1.020	1.017	1.014	1.012	1.009	1.006	1.003	1.000	0.997	0.995
0.69	1.049	1.046	1.043	1.040	1.037	1.035	1.032	1.029	1.026	1.023
0.68	1.078	1.075	1.072	1.069	1.066	1.064	1.061	1.058	1.055	1.052
0.67	1.108	1.105	1.102	1.099	1.096	1.093	1.090	1.087	1.084	1.081
0.66	1.138	1.135	1.132	1.129	1.126	1.123	1.120	1.117	1.114	1.111
0.65	1.169	1.166	1.163	1.160	1.157	1.154	1.151	1.147	1.144	1.141
0.64	1.201	1.197	1.194	1.191	1.188	1.185	1.182	1.179	1.175	1.172
0.63	1.233	1.229	1.226	1.223	1.220	1.217	1.213	1.210	1.207	1.204
0.62	1.265	1.262	1.259	1.256	1.252	1.249	1.246	1.242	1.239	1.236

Power Factor	Third Decimal Accuracy Power Factor (Add to Left-Most Column Power Factor Result)									
	0.000	0.001	0.002	0.003	0.004	0.005	0.006	0.007	0.008	0.009
	Tangents Corresponding to Power Factor Angle									
0.61	1.299	1.296	1.292	1.289	1.286	1.282	1.279	1.275	1.272	1.269
0.60	1.333	1.330	1.326	1.323	1.320	1.316	1.313	1.309	1.306	1.302
0.59	1.368	1.365	1.361	1.358	1.354	1.351	1.347	1.344	1.340	1.337
0.58	1.405	1.401	1.397	1.394	1.390	1.386	1.383	1.379	1.376	1.372
0.57	1.441	1.438	1.434	1.430	1.427	1.423	1.419	1.416	1.412	1.408
0.56	1.479	1.476	1.472	1.468	1.464	1.460	1.457	1.453	1.449	1.445
0.55	1.518	1.515	1.511	1.507	1.503	1.499	1.495	1.491	1.487	1.483
0.54	1.559	1.555	1.551	1.546	1.542	1.538	1.534	1.530	1.526	1.522
0.53	1.600	1.596	1.592	1.587	1.583	1.579	1.575	1.571	1.567	1.563
0.52	1.643	1.638	1.634	1.630	1.625	1.621	1.617	1.613	1.608	1.604
0.51	1.687	1.682	1.678	1.673	1.669	1.664	1.660	1.656	1.651	1.647
0.50	1.732	1.727	1.723	1.718	1.714	1.709	1.705	1.700	1.696	1.691
0.49	1.779	1.774	1.770	1.765	1.760	1.755	1.751	1.746	1.741	1.737
0.48	1.828	1.823	1.818	1.813	1.808	1.803	1.798	1.793	1.789	1.784
0.47	1.878	1.873	1.868	1.863	1.858	1.853	1.848	1.843	1.838	1.833
0.46	1.930	1.925	1.920	1.914	1.909	1.904	1.899	1.893	1.888	1.883
0.45	1.985	1.979	1.973	1.968	1.963	1.957	1.952	1.946	1.941	1.936
0.44	2.041	2.035	2.029	2.024	2.018	2.012	2.007	2.001	1.996	1.990
0.43	2.100	2.094	2.088	2.082	2.076	2.070	2.064	2.058	2.052	2.047
0.42	2.161	2.155	2.148	2.142	2.136	2.130	2.124	2.118	2.112	2.106
0.41	2.225	2.218	2.212	2.205	2.199	2.192	2.186	2.180	2.173	2.167
0.40	2.291	2.284	2.278	2.271	2.264	2.258	2.251	2.244	2.238	2.231
0.39	2.361	2.354	2.347	2.340	2.333	2.326	2.319	2.312	2.305	2.298
0.38	2.434	2.427	2.419	2.412	2.405	2.397	2.390	2.383	2.375	2.368
0.37	2.511	2.503	2.495	2.487	2.480	2.472	2.464	2.457	2.449	2.442
0.36	2.592	2.583	2.575	2.567	2.559	2.551	2.543	2.535	2.527	2.519
0.35	2.676	2.668	2.659	2.650	2.642	2.633	2.625	2.617	2.608	2.600
0.34	2.766	2.757	2.748	2.739	2.730	2.721	2.712	2.703	2.694	2.685
0.33	2.861	2.851	2.841	2.832	2.822	2.813	2.803	2.794	2.784	2.775
0.32	2.961	2.950	2.940	2.930	2.920	2.910	2.900	2.890	2.880	2.870
0.31	3.067	3.056	3.045	3.034	3.024	3.013	3.002	2.992	2.981	2.971
0.30	3.180	3.168	3.157	3.145	3.134	3.122	3.111	3.100	3.089	3.078

To determine average power factor, divide the measured reactive volt-ampere-hour meter reading by the watt-hour meter reading. Find the value that closely approximates your calculation in Table A1, then read across the same row to the left-most column for the power factor. For three-decimal accuracy, find the value that closely approximates your calculated value again in Table A1, then read straight up the column in which the value appears to the table's second row and add the value in the second row (i.e., 0.000, 0.001, 0.0002, etc.) to the power factor determined previously.

APPENDIX B CAPACITOR RATING TABLE FOR MOTORS

Table B1: Maximum Capacitor Rating for Motors/Capacitors Switched as a Unit

Induction Motor Horse-Power Rating	Nominal Motor Speed in RPM											
	3,600 RPM		1,800 RPM		1,200 RPM		900 RPM		720 RPM		600 RPM	
	Cap. Rating kVAr	Line Current Reduction %	Cap. Rating kVAr	Line Current Reduction %	Cap. Rating kVAr	Line Current Reduction %	Cap. Rating kVAr	Line Current Reduction %	Cap. Rating kVAr	Line Current Reduction %	Cap. Rating kVAr	Line Current Reduction %
3.0	1.5	14	1.5	15	1.5	20	2.0	27	2.5	35	3.0	41
5.0	2.0	12	2.0	13	2.0	17	3.0	25	4.0	32	4.0	37
7.5	2.5	11	2.5	12	3.0	15	4.0	22	5.0	30	6.0	34
10.0	3.0	10	3.0	11	3.0	14	5.0	21	6.0	27	7.5	31
15.0	4.0	9	4.0	10	5.0	13	6.0	18	8.0	23	9.0	27
20.0	5.0	9	5.0	10	6.0	12	7.5	16	9.0	21	12.5	25
25.0	6.0	9	6.0	10	7.5	11	9.0	15	10.0	20	15.0	23
30.0	7.0	8	7.0	9	9.0	11	10.0	14	12.5	18	17.5	22
40.0	9.0	8	9.0	9	10.0	10	12.5	13	15.0	16	20.0	20
50.0	12.5	8	10.0	9	12.5	10	15.0	12	20.0	15	25.0	19
60.0	15.0	8	15.0	8	15.0	10	17.5	11	22.5	15	27.5	19
75.0	17.5	8	17.5	8	17.5	10	20.0	10	25.0	14	35.0	18
100.0	22.5	8	20.0	8	25.0	9	27.5	10	35.0	13	40.0	17
125.0	27.5	8	25.0	8	30.0	9	30.0	10	40.0	13	50.0	16
150.0	30.0	8	30.0	8	35.0	9	37.5	10	50.0	12	50.0	15
200.0	40.0	8	37.5	8	40.0	9	50.0	10	60.0	12	60.0	14
250.0	50.0	8	45.0	7	50.0	8	60.0	9	70.0	11	75.0	13
300.0	60.0	8	50.0	7	60.0	8	60.0	9	80.0	11	90.0	12
350.0	60.0	8	60.0	7	75.0	8	75.0	9	90.0	10	95.0	11
400.0	75.0	8	60.0	6	75.0	8	85.0	9	95.0	10	100.0	11
450.0	75.0	8	75.0	6	80.0	8	90.0	9	100.0	9	110.0	11
500.0	75.0	8	75.0	6	85.0	8	100.0	9	100.0	9	120.0	10

Table Notes:

For use with 3-phase, 60-hertz, NEMA Design B motors to raise full load power factor to approximately 95%.

When manual, reduced-voltage, auto-transformer type starters are used, motor and load characteristics have to be considered in order to keep mechanical torque in motor shaft and coupling below six times normal.

kVAr is rated kVA of capacitor connected at motor terminals.

Percent reduction in line current due to capacitor is helpful for selecting the proper motor overload setting when the overload device carries the sum of motor and capacitor currents.

For new motors and other NEMA standard design motors, follow the manufacturer's recommendation for maximum capacitor rating when motor and capacitor are switched as a unit.

Taken from Table 3, Page 10, of *Power Factor Correction: A Guide for the Plant Engineer*.