



TRANSMISSION PRODUCTS INDEX

DEADENDS

BOLTED/ALUMINUM

AR1/AR2.....	QUADRANT STRAIN CLAMP	TA-4
PG/DE	QUADRANT STRAIN CLAMP	TA-3
SD.....	QUADRANT STRAIN CLAMP	TA-1
SDT2	DOUBLE GROOVE STRAIN CLAMP	TA-2

BOLTED/BRONZE

BR1/BR2.....	QUADRANT STRAIN CLAMP	TA-6
BSD	QUADRANT STRAIN CLAMP	TA-5

BOLTED/DUCTILE

DDC.....	CIRCULAR CLAMP	TA-9
DDT	DEADEND THIMBLE.....	TA-9
MDE.....	STRAIGHT LINE STRAIN CLAMP	TA-8
SWDE/MD	QUADRANT STRAIN CLAMP	TA-7

COMPRESSION/ALUMINUM

A01/A03.....	UNI-GRIP® EYE TYPE, SINGLE TONGUE-ACSR	TA-10
A02/A04.....	UNI-GRIP® EYE TYPE, DOUBLE TONGUE-ACSR.....	TA-12
A09/A10.....	UNI-GRIP® ADJUSTABLE CLEVIS TYPE-ACSR	TA-14
AB01/AB03	UNI-GRIP® EYE TYPE, SINGLE TONGUE-ALLOY & ACAR	TA-16
AB02/AB04	UNI-GRIP® EYE TYPE, DOUBLE TONGUE-ALLOY & ACAR.....	TA-17
AB09/AB10	UNI-GRIP® ADJUSTABLE CLEVIS TYPE-ALLOY & ACAR	TA-18
C01/C03	UNI-GRIP® EYE TYPE, SINGLE TONGUE-AAC.....	TA-19
C02/C04	UNI-GRIP® EYE TYPE, DOUBLE TONGUE-AAC	TA-21
C09/C10	UNI-GRIP® ADJUSTABLE CLEVIS TYPE-AAC.....	TA-23
SEDA/DEDA	CONVENTIONAL TWO-DIE SYSTEM-ACSR	TA-26
SEDA/DEDA	CONVENTIONAL TWO-DIE SYSTEM-ACSS	TA-28
SEDA/DEDA	CONVENTIONAL TWO-DIE SYSTEM-ACSS/TW.....	TA-30
21.....	CONVENTIONAL DEADEND ACCESSORIES AAC.....	TA-32

COMPRESSION/GALVANIZED STEEL

86.....	STATIC WIRE DEADEND ALUMOWELD® & EHS STEEL	TA-33
---------	--	-------

TOWER GUY/WEDGE/FORMED WIRE

GA/AWA0.....	TOWER GUY DEADEND NON-ADJUSTABLE	TA-34
GA/AWA18.....	TOWER GUY DEADEND ADJUSTABLE	TA-37



DEADENDS BOLTED QUADRANT STRAIN CLAMP ALUMINUM

ALUMINUM
SD

For transmission line construction with all aluminum, ACSR or aluminum alloy conductor.

Material: Body and Keeper—356-T6 aluminum alloy
Hardware—galvanized steel
Sockets and Clevises—ductile iron, galvanized
Cotter Pin—#302 stainless steel

TA-1



CATALOG NUMBER	DIMENSIONS INCHES (MM)					
	L	W	H	C	K	PD
SD57	9-1/16 (230.19)	3/4 (19.05)	6-3/4 (171.45)	5-1/8 (130.18)	1-1/4 (31.75)	5/8 (15.88)
SD70	10-1/4 (260.35)	15/16 (23.81)	(171.45)	(130.18)	(31.75)	(15.88)
SD86	11-1/4 (285.75)	8-3/8 (212.73)	9-5/8 (244.48)	7-3/8 (187.33)	1-1/4 (31.75)	5/8 (15.88)
SD112	13-1/8 (333.38)	1-3/8 (34.93)	11-1/2 (292.1)	8-1/4 (209.6)	1-3/8 (34.33)	3/4 (19.05)
SD130	14 (355.6)	1-7/16 (36.51)	13-1/8 (333.38)	9-1/2 (241.3)	1-1/2 (38.10)	3/4 (19.05)
SD155	15-1/2 (393.70)	2 (50.8)	15-3/4 (400.05)	12-3/8 (314.32)	1-1/2 (38.10)	3/4 (19.05)
SD155	17 (431.80)	1-7/8 (47.63)	18 (457.20)	12-3/8 (314.32)	1-1/2 (38.10)	1 (25.40)

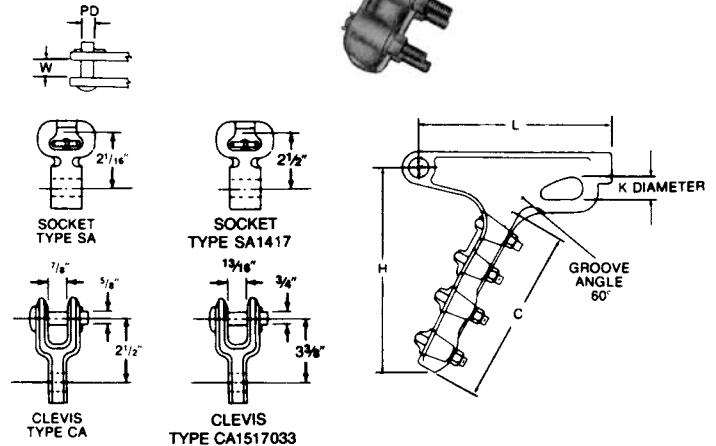

CATALOG NUMBER	FITTING		CLAMPING RANGE			ULTIMATE BODY STRENGTH LBS. (KN)	U-BOLTS		APPROX. WT. EACH LBS. (KG)
	TYPE	CAT. NO.	ACSR	ALUMINUM	INCHES (MM)		NO.	SIZE INCHES (MM)	
SD57N S	None	--	#4-6/1	#4-7 Str.	.20-.64	15,000 (67)	3	1/2 (12.70)	3.2 (1.45) 4.4 (2.00) 4.8 (2.63)
D57S	Socket	SA04	To	To	(5.08-16.26)				
SD57C	Clevis	CA04	266.8-26/7	300-37 Str.					
SD70N	None	--	#2-7/1	#1-7 Str.	.30-.75	20,000 (89)	4	1/2 (12.70)	4.7 (2.14) 6.0 (2.72) 6.4 (2.90)
SD70S	Socket	SA06	To	To	(7.62-19.05)				
SD70C	Clevis	CA06	397.5-18/1	397.5-37 Str.					
SD86N	None	--	#3/0-6/1	3/0-19 Str.	.46-.94	25,000 (111)	4	1/2 (12.70)	5.4 (2.45) 6.8 (3.09) 7.1 (3.22)
SD86S	Socket	SA07	To	To	(10.16-23.88)				
SD86C	Clevis	CA06	556-26/7	650-61 Str.					
SD112N	None	--	#3/0-6/1	4/0-19 Str.	.50-1.20	30,000 (133)	5	1/2 (12.70)	8.4 (3.81) 9.9 (4.5) 10.4 (4.73)
SD112S	Socket	SA1013	To	To	(12.80-30.48)				
SD112C	Clevis	CA1013	954-54/7	1033.5-61 Str.					
SD130N	None	--	336.4-26/7	397.5-19 Str.	.70-1.39	35,000 (156)	5	5/8 (15.88)	13.2 (6.00) 15.3 (6.95) 15.5 (7.04)
SD130S	Socket	SA1013	To	To	(17.78-35.30)				
SD130C	Clevis	CA1013	1272-54/19	1431-61 Str.					
SD155N	None	--	1,033.5 (36/1)	1,100-91 Str.	1.18-1.55	30,000 (133)	5	5/8 (15.88)	15.5 (7.00) 17.3 (7.85) 17.3 (7.85)
SD155S	Socket	SA1613	To	To	(29.97-38.61)				
SD155C	Clevis	CA1613	1510.5 (54/19)	1,700-127 Str.					
SD185N	None	--	1,192.5 (45/7)	1,272-61 Str.	1.30-1.85	50,000 (222)	5	5/8 (15.88)	21.0 (9.53) 22.7 (10.30) 22.3 (10.11)
SD185S	Socket	SA1417	To	To	(33.02-46.99)				
SD185C	Clevis	CA1517033	2,156 (84/19)	2,500-127 Str.					

- NOTES:
- (1) Sag Eye Ultimate Strength is 60% of Ultimate Body Strength without fitting.
 - (2) Rated slip strength as a % of conductor RBS varies with conductor type, size and stranding. Minimum slip strength rating on standard strength conductors is 40% RBS (Partial Tension). For most standard strength conductors, minimum slip strength of this clamp series is 60% RBS (Normal Tension). (Consult factory for slip strength test data on specific clamp & conductor combinations.)
 - (3) Recommended torque on u-bolts: 1/2" -- 480 in-lbs., 5/8" -- 720 in-lbs.
 - (4) Bolt and Nut may be substituted for clevis pin by adding suffix "BNK" to catalog number.
 - (5) For corona-free applications on EHV lines, add suffix "CRF" to catalog number. Example SD130NCRF.



ALUMINUM
STD2

DEADENDS BOLTED DOUBLE GROOVE STRAIN CLAMP ALUMINUM

TA-2

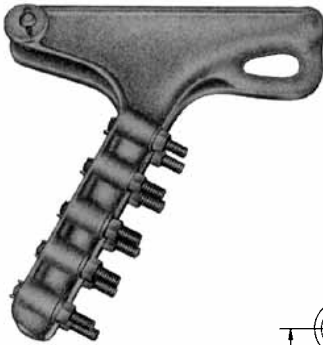

Made with double groove keeper to accommodate twin conductor. For transmission line construction with all aluminum, ACSR or aluminum alloy conductor.

Material: Body and Keeper—356-T6 aluminum alloy
Hardware—galvanized steel
Sockets and clevises—ductile iron, galvanized
Cotter Pin—stainless steel

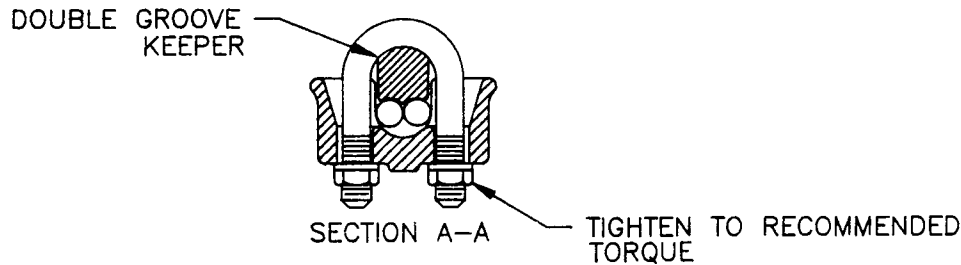
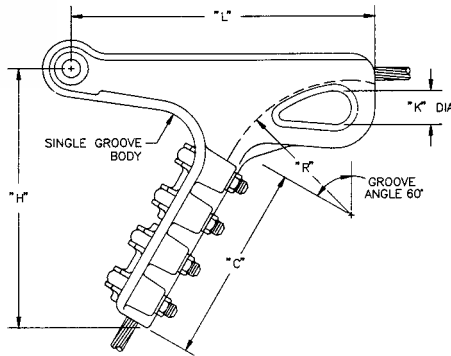

CATALOG NUMBER	CLAMPING RANGE			ULTIMATE BODY STRENGTH LBS.	U-BOLTS		DIMENSIONS						APPROX. WT. EACH LBS.	
	ACSR	ALUMINUM	INCHES		NO.	SIZE	L	H	C	K	PD	R		X
SDT286N	1/0-6/1	2/0-7 STR.	.398	25,000	4	1/2	11-1/4	9-5/8	7-3/8	1-1/4	5/8	5	1-1/16	5.4
SDT286S	To	To	To	25,000										6.0
SDT286C	2/0-6/1	2/0-19 STR	.447	25,000										6.4
SDT2112N	3/0-6/1	4/0-7 STR	.502	30,000	5	1/2	13-1/8	11-1/2	8-1/4	1-3/8	3/4	6-1/2	1-3/8	8.4
SDT2112S	To	To	To	30,000										9.9
SDT2112C	4/0-6/1	4/0-19 STR	.562	25,000										10.0
SDT2185N	226.8-26/7	336.4-19 STR	.642	50,000	5	1/2	17	18	12-3/8	1-1/2	1	12	1-7/8	21.0
SDT2185S	To	To	To	30,000										22.7
SDT2185C	556.5-18/1	556.5-37 STR	.879	30,000										22.3

- NOTES:
- (1) Sag Eye Ultimate Strength is 60% of Ultimate Body Strength without fitting.
 - (2) Rated slip strength as a % of conductor RBS varies with conductor type, size and stranding. Minimum slip strength rating on standard strength conductors is 40% RBS (Partial Tension). For most standard strength conductors, minimum slip strength of this clamp series is 60% RBS (Normal Tension). (Consult factory for slip strength test data on specific clamp & conductor combinations.)
 - (3) Recommended torque on u-bolts: 1/2" -- 480 in-lbs., 5/8" -- 720 in-lbs.
 - (4) Bolt and Nut may be substituted for clevis pin by adding suffix "BNK" to catalog number.
 - (5) For corona-free applications on EHV lines, add suffix "CRF" to catalog number. Example SD130NCRF.



DEADENDS BOLTED QUADRANT STRAIN CLAMP ALUMINUM

ALUMINUM
PG/DE

TA-3

For distribution and light transmission construction with all aluminum, ACSR or aluminum alloy conductor.

Material: Body and Keeper—356-T6 aluminum alloy
Hardware—galvanized steel
Sockets and Clevises—ductile iron, galvanized
Cotter Pin—#302 stainless steel

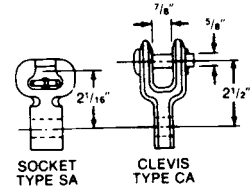
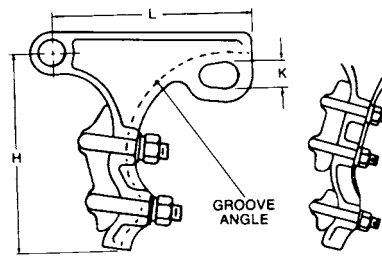
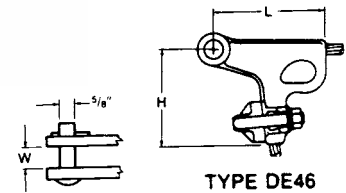

CATALOG NUMBER	DIMENSIONS INCHES (MM)			
	L	W	H	K
DE46	3-7/8 (98.30)	11/16 (17.46)	3-13/16 (96.84)	7/8 (22.10)
PG46	4-1/16 (103.18)	11/16 (17.46)	4-3/4 (120.65)	1 (25.40)
PG57	5-1/2 (139.7)	11/16 (17.46)	5-5/16 (134.87)	1 (25.40)
PG70	6-7/16 (163.51)	25/32 (19.84)	7 (177.80)	1-1/8 (28.58)
PG86	12-5/16 (312.74)	1-1/16 (26.99)	11 (279.40)	1-1/4 (31.75)
PG86L	6-9/16 (166.69)	1-1/16 (26.99)	7-7/16 (188.91)	1 (25.40)
PG100L	9-7/8 (250.83)	1-3/16 (30.16)	9-5/16 (236.54)	1-1/4 (31.75)

CATALOG NUMBER	FITTING		CLAMPING RANGE		ULTIMATE BODY STRENGTH LBS. (KN)	U-BOLTS		GROOVE ANGLE	APPROX. WT. EACH LBS. (KG)	
	TYPE	CAT. NO.	ACSR	ALUMINUM		INCHES (MM)	NO.			SIZE INCHES (MM)
DE46N	None	--	#6 (6/1)	#6-7 Str.	.18-.52 (4.57-13.21)	8,000 (33)	1	1/2 (12.70)	85°	1.2 (.54)
DE46S	Socket	SA04	To	To						2.2 (1.00)
DE46C	Clevis	CA04	3/0 (6/1)	3/0-19 Str.						2.2 (1.00)
PG46N**	None	--	#6 (6/1)	#6-7 Str.	.18-.52 (4.57-13.21)	8,000 (33)	2	1/2 (12.70)	90°	1.1 (.50)
PG46S	Socket	SA04	To	To						2.4 (1.08)
PG46C	Clevis	CA04	3/0 (6/1)	3/0-19 Str.						2.7 (1.22)
PG57N**	None	--	#4 (6/1)	#3-7 Str.	.25-.57 (6.35-14.48)	10,000 (44)	2	1/2 (12.70)	90°	2.0 (.91)
PG57S	Socket	SA04	To	To						3.2 (1.45)
PG57C	Clevis	CA04	4/0 (6/1)	4/0-19 Str.						3.6 (1.63)
PG70N	None	--	101.8 (12/7)	3/0-7 Str.	.46-.73 (11.68-18.54)	15,000 (67)	2	1/2 (12.70)	85°	2.5 (1.13)
PG70S	Socket	SA04	To	To						3.8 (1.72)
PG70C	Clevis	CA04	336.4 (26/7)	400-37 Str.						4.1 (1.86)
PG86LN	None	--	134.6 (12/7)	4/0-7 Str.	.52-.88 (13.21-22.35)	15,000 (67)	2	1/2 (12.70)	70°	2.9 (1.32)
PG86LS	Socket	SA07	To	To						4.2 (1.91)
PG86LC	Clevis	CA06	556.5 (18/1)	556.5-37 Str.						4.6 (2.09)
PG100LN	None	--	3/0 (6/1)	4/0-7 Str.	.50-1.00 (12.70-25.40)	18,000 (80)	2	1/2 (12.70)	60°	4.5 (2.04)
PG100LS	Socket	SA10	To	To						5.9 (2.68)
PG100LC	Clevis	CA101	666.6 (24/7)	750-61 Str.						6.2 (2.81)

- NOTES:**
- (1) Sag Eye Ultimate Strength is 60% of Ultimate Body Strength without fitting.
 - (2) Rated slip strength as a % of conductor RBS varies with conductor type, size and stranding. Minimum slip strength rating on standard strength conductors is 40% RBS (Partial Tension). For many standard strength conductors, minimum slip strength of this clamp series is 60% RBS (Normal Tension). (Consult factory for slip strength test data on specific clamp & conductor combinations.)
 - (3) Recommended torque on u-bolts: 3/8" -- 240 in-lbs., 1/2" -- 480 in-lbs.
 - (4) Bolt and Nut may be substituted for clevis pin by adding suffix "BNK" to catalog number.

**RUS Listed



DEADENDS BOLTED QUADRANT STRAIN CLAMP ALUMINUM

ALUMINUM
AR1/AR2

TA-4



These clamps are used primarily for deadending aluminum substation cable bus.

During installation the cable will slide free under the U-bolts, or if preferred, U-bolts may be removed and cable laid in clamp grooves from the side.

These clamps are compact for greatest phase clearance.

Material: Body and Keeper—356-T6 aluminum alloy
Hardware—galvanized steel
Sockets and Clevises—ductile iron, galvanized
Cotter Pin—#302 stainless steel

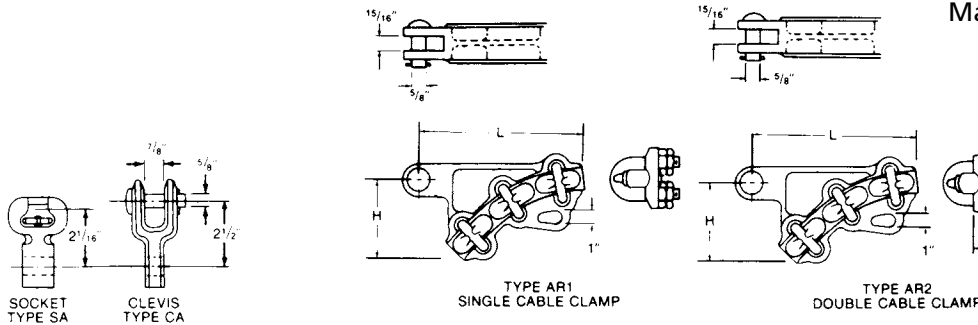

CATALOG NUMBER	FITTING		CLAMPING RANGE			ULTIMATE BODY STRENGTH LBS. (KN)	U-BOLTS		DIMENSIONS INCHES (MM)			APPROX. WT. EACH LBS. (KG)
	TYPE	CAT. NO.	ACSR	ALUMINUM	INCHES (MM)		NO.	SIZE INCHES (MM)	L	W	H	
AR1100N	None	--	477 (18/1)	500	.811-1.152	15,000	3	1/2	9-1/8	--	3-7/8	3.5 (1.59)
AR1100S	Socket	SA06	To	To	(20.60-29.26)	(67)		(12.70)	(231.78)		(98.43)	4.8 (2.18)
AR1100C	Clevis	CA06	874.5 (54/7)	1000 MCM								5.2 (2.36)
AR1150N	None	--	900 (54/7)	1000	1.150-1.412	15,000	3	5/8	10-1/2	--	4-3/8	5.2 (2.36)
AR1150S	Socket	SA06	To	To	(29.21-35.86)	(67)		(15.88)	(266.70)		(111.13)	6.5 (2.95)
AR1150C	Clevis	CA06	1351.5 (45/7)	1500 MCM								6.9 (3.13)
AR1200N	None	--	1351.5 (45/7)	1500	1.411-1.632	15,000	3	5/8	12-3/4	--	5	6.0 (2.72)
AR1200S	Socket	SA06	To	To	(35.84-41.45)	(67)		(15.88)	(323.85)		(127)	7.3 (3.31)
AR1200C	Clevis	CA06	1780 (84/19)	2000 MCM								7.7 (3.49)
AR2025N	None	--	1/0 (6/1)	1/0	.365-.574	8,000	3	3/8	8-1/16	21/32	3-5/32	2.7 (1.22)
AR2025S	Socket	SA06	To	To	(9.27-14.58)	(36)		(9.53)	(204.7)	(16.67)	(80.17)	4.0 (1.81)
AR2025C	Clevis	CA06	4/0 (6/1)	250-19 Str.								4.4 (2.00)
AR2050N	None	--	159 (12/7)	250	.574-.813	10,000	3	1/2	8-3/4	7/8	3-1/4	3.5 (1.59)
AR2050S	Socket	SA06	To	To	(14.58-20.65)	(44)		(12.70)	(222.25)	(22.23)	(82.55)	4.8 (2.18)
AR2050C	Clevis	CA06	477 (36/1)	500 MCM								5.2 (2.36)
AR2100N	None	--	477 (18/1)	500	.811-1.152	15,000	3	1/2	9-1/8	1-3/16	3-7/8	4.2 (1.91)
AR2100S	Socket	SA06	To	To	(20.60-29.26)	(67)		(12.70)	(231.78)	(30.16)	(98.43)	5.5 (2.49)
AR2100C	Clevis	CA06	874.5 (54/7)	1000 MCM								5.9 (2.68)
AR2150N	None	--	900 (54/7)	1000	1.150-1.412	15,000	3	5/8	10-1/2	1-21/32	4-3/8	7.5 (3.40)
AR2150S	Socket	SA06	To	To	(29.21-35.86)	(67)		(15.88)	(266.70)	(42.06)	(111.13)	8.8 (3.99)
AR2150C	Clevis	CA06	1351.5 (45/7)	1500 MCM								9.2 (4.17)
AR2200N	None	--	1351.5 (54/19)	1500	1.411-1.630	15,000	3	5/8	12-3/4	2-3/32	5	8.5 (3.86)
AR2200S	Socket	SA06	To	To	(35.84-41.40)	(67)		(15.88)	(323.85)	(53.18)	(127)	9.8 (4.45)
AR2200C	Clevis	CA06	1780 (84/19)	2000 MCM								10.2 (4.63)

- NOTES: (1) Sag Eye Ultimate Strength is 60% of Ultimate Body Strength without fitting.
 (2) Rated slip strength as a % of conductor RBS varies with conductor type, size and stranding. Minimum slip strength rating on standard strength conductors is 40% RBS (Partial Tension). For many standard strength conductors, minimum slip strength of this clamp series is 60% RBS (Normal Tension). (Consult factory for slip strength test data on specific clamp & conductor combinations.)
 (3) Recommended torque on u-bolts: 3/8" -- 240 in-lbs., 1/2" -- 480 in-lbs.
 (4) Bolt and Nut may be substituted for clevis pin by adding suffix "BNK" to catalog number.

DEADENDS BOLTED QUADRANT STRAIN CLAMP BRONZE

BRONZE
BSD

TA-5

For heavy duty application using copper or Copperweld® conductor.

Material: Body—high strength aluminum bronze alloy
 Keeper—electrical bronze
 Hardware—galvanized steel
 Sockets and Clevises—ductile iron, galvanized
 Cotter Pin—#302 stainless steel

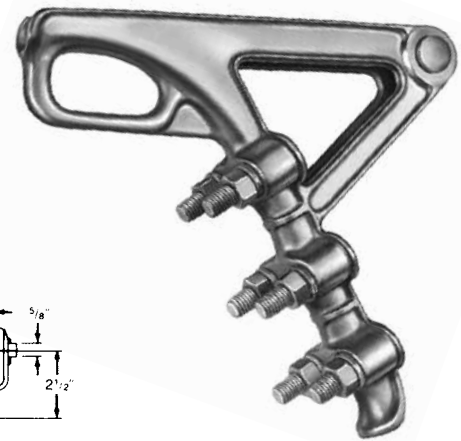

CATALOG NUMBER	DIMENSIONS INCHES (MM)				
	L	W	C	K	PD
BSD55	10 (254)	11/16 (17.46)	7-1/2 (190.50)	1-1/4 (31.75)	5/8 (15.88)
BSD68	11 (279.40)	3/4 (19.05)	9-1/2 (241.30)	1-5/16 (33.34)	5/8 (15.88)
BSD84	12 (304.80)	1 (25.40)	12 (304.80)	1-1/4 (31.75)	5/8 (15.88)
BSD112	13-1/8 (333.38)	1-3/8 (34.93)	8-1/4 (209.60)	1-1/2 (38.10)	3/4 (19.05)
BSD130	14 (355.60)	1-7/16 (36.51)	9-1/2 (241.30)	1-23/32 (43.7)	3/4 (19.05)

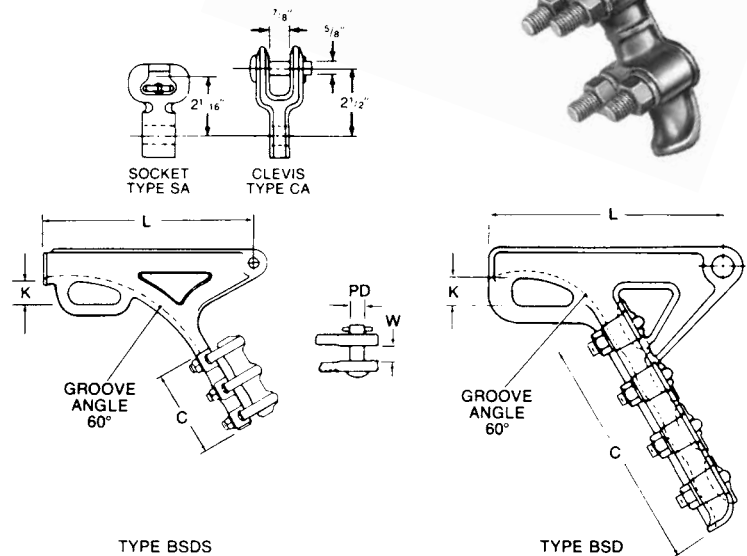

CATALOG NUMBER	FITTING		CLAMPING RANGE		ULTIMATE BODY STRENGTH LBS. (KN)	U-BOLTS		APPROX. WT. EACH LBS. (KG)
	TYPE	CAT. NO.	COPPER	INCHES (MM)		NO.	SIZE INCHES (MM)	
BSD55N	None	--		.200-.500	18,000 (80)	3	1/2	6.4 (2.90)
BSD55S	Socket	SA04	#4 Sol.-4/0 Str.	(5.08-13.97)	18,000 (80)	3	(12.70)	7.7 (3.49)
BSD55C	Clevis	CA04			18,000 (80)	3		7.2 (3.27)
BSD68N	None	--		.300-.680	25,000 (111)	4	1/2	8.7 (3.95)
BSD68S	Socket	SA04	1/0 Sol.-350-19 Str.	(7.62-17.27)	20,000 (89)	4	(12.70)	10.0 (4.54)
BSD68C	Clevis	CA04			18,000 (80)	4		10.0 (4.54)
BSD84N	None	--		.475-.840	25,000 (111)	4	1/2	12.7 (5.76)
BSD84S	Socket	SA06	4/0 Str.-500 MCM	(12.07-21.34)	25,000 (111)	4	(12.70)	14.0 (6.35)
BSD84C	Clevis	CA06			25,000 (111)	4		14.4 (6.53)
BSD112N	None	--		.710-1.15	35,000 (156)	5	1/2	14.8 (6.71)
BSD112S	Socket	SA1013	400-1000 MCM	(18.03-29.21)	30,000 (133)	5	(12.70)	16.3 (7.39)
BSD112C	Clevis	CA1013			25,000 (111)	5		16.8 (7.62)
BSD130N	None	--		.710-1.42	35,000 (156)	5	5/8	24.5 (11.11)
BSD130S	Socket	SA1113	400-1500 MCM	(18.03-36.07)	30,000 (133)	5	(15.88)	26.0 (11.79)
BSD130C	Clevis	CA1013			25,000 (111)	5		26.5 (12.02)

- NOTES: (1) Sag Eye Ultimate Strength is 60% of Ultimate Body Strength without fitting.
 (2) Rated slip strength as a % of conductor RBS varies with conductor type, size and stranding. Minimum slip strength rating on standard strength conductors is 40% RBS (Partial Tension). For most standard strength conductors, minimum slip strength of this clamp series is 60% RBS (Normal Tension). (Consult factory for slip strength test data on specific clamp & conductor combinations).
 (3) Recommended torque on u-bolts: 1/2" -- 480 in-lbs., 5/8" -- 720 in-lbs.
 (4) Bolt and Nut may be substituted for clevis pin by adding suffix "BNK" to catalog number.



DEADENDS BOLTED QUADRANT STRAIN CLAMP BRONZE

BRONZE
BR1/BR2

TA-6

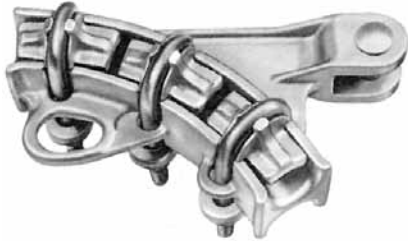

These clamps are used primarily for deadending copper substation cable bus.

When installing, cable will slide freely under the U-bolts. If preferred, U-bolts may be removed and cable laid in clamp grooves from the side.

These clamps are compact for greatest phase clearance.

Material: Body and Keeper—high strength bronze
Hardware—galvanized steel
Sockets and Clevises—ductile iron, galvanized
Cotter Pin—#302 stainless steel

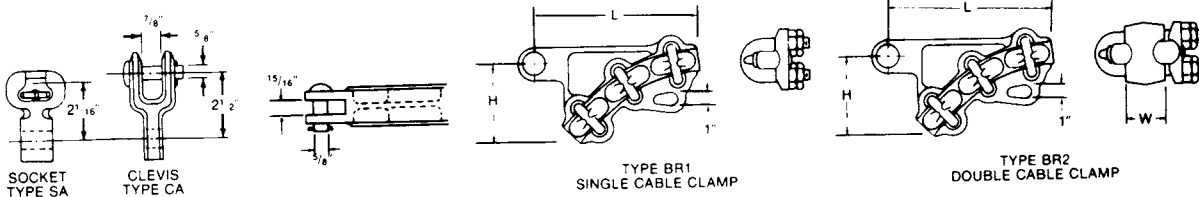

CATALOG NUMBER	FITTING		CLAMPING RANGE		ULTIMATE BODY STRENGTH LBS. (KN)	U-BOLTS		DIMENSIONS INCHES (MM)			APPROX. WT. EACH LBS. (KG)
	TYPE	CAT. NO.	COPPER	INCHES (MM)		NO.	SIZE INCHES (MM)	L	W	H	
BR1025N	None	--	2/0 Sol.	.365-.574 (9.27-14.58)	8,000 (36)	3	3/8 (9.53)	8-1/16 (204.79)	--	3-5/32 (80.17)	5.4 (2.45)
BR1025S	Socket	SA06	To								
BR1025C	Clevis	CA06	250-19 Str.								
BR1050N	None	--	250-19 Str.	.574-.813 (14.58-20.65)	10,000 (44)	3	1/2 (12.70)	8-7/8 (225.43)	--	3-3/8 (85.73)	7.0 (3.18)
BR1050S	Socket	SA06	To								
BR1050C	Clevis	CA06	500 MCM								
BR1100N	None	--	500	.811-1.152 (20.60-29.26)	15,000 (67)	3	1/2 (12.70)	9-1/8 (231.78)	--	3-7/8 (98.43)	9.2 (4.17)
BR1100S	Socket	SA06	To								
BR1100C	Clevis	CA06	1000 MCM								
BR1150N	None	--	1000	1.150-1.412 (29.21-35.86)	15,000 (67)	3	5/8 (15.88)	10-1/2 (266.70)	--	4-3/8 (111.13)	13.4 (6.08)
BR1150S	Socket	SA06	To								
BR1150C	Clevis	CA06	1500 MCM								
BR1200N	None	--	1500 MCM	1.411-1.632 (35.84-41.40)	15,000 (67)	3	5/8 (15.88)	12-3/4 (323.85)	--	5 (127)	15.0 (6.80)
BR1200S	Socket	SA06	To								
BR1200C	Clevis	CA06	2000-Str.								
BR2025N	None	--	2/0 Sol.	.365-.574 (9.27-14.58)	8,000 (36)	3	3/8 (9.53)	8-1/16 (204.79)	21/32 (16.67)	3-5/32 (80.17)	5.7 (2.59)
BR2025S	Socket	SA06	To								
BR2025C	Clevis	CA06	250-19 Str.								
BR2050N	None	--	250-19 Str.	.574-.813 (14.58-20.65)	10,000 (44)	3	1/2 (12.70)	8-3/4 (222.25)	7/8 (22.23)	3-1/4 (82.55)	10.0 (4.54)
BR2050S	Socket	SA06	To								
BR2050C	Clevis	CA06	500 MCM								
BR2100N	None	--	500	.811-1.152 (20.60-29.26)	15,000 (67)	3	1/2 (12.70)	9-1/8 (231.78)	1-3/16 (30.16)	3-7/8 (98.43)	14.0 (6.35)
BR2100S	Socket	SA06	To								
BR2100C	Clevis	CA06	1000 MCM								

- NOTES: (1) Sag Eye Ultimate Strength is 60% of Ultimate Body Strength without fitting.
 (2) Rated slip strength as a % of conductor RBS varies with conductor type, size and stranding. Minimum slip strength rating on standard strength conductors is 40% RBS (Partial Tension). For many standard strength conductors, slip strength ratings will meet 60% RBS (Normal Tension). (Consult factory for slip strength test data on specific clamp & conductor combinations).
 (3) Recommended torque on u-bolts: 3/8" -- 240 in-lbs., 1/2" -- 480 in-lbs.
 (4) Bolt and Nut may be substituted for clevis pin by adding suffix "BNK" to catalog number.

DEADENDS BOLTED QUADRANT STRAIN CLAMP DUCTILE IRON

DUCTILE IRON
SWDE/MD

TA-7

For deadending static wires.

May be used to deadend copper or Copperweld® phase conductors. Magnetic induction heating will occur.

Material: Body and Keeper—galvanized ductile iron
Sockets and Clevises—ductile iron, galvanized
Cotter Pin—#302 stainless steel



CATALOG NUMBER	DIMENSIONS INCHES (MM)			
	L	H	C	W
MD52N	2-25/32	4-3/32	2-1/8	5/8
MD52S	(70.61)	(103.89)	(54.10)	(15.88)
MD52C				
SWDE46N	6	5-1/2	4-3/8	5/8
SWDE46S	(152.40)	(139.70)	(111.12)	(15.88)
SWDE46C				
SWDE55N	8	8-5/8	7-3/8	11/16
SWDE55S	(203.20)	(219.08)	(187.33)	(17.46)
SWDE55C				
SWDE84N	10-3/4	10-5/8	8-7/16	15/16
SWDE84S	(273.05)	(270.00)	(214.38)	(23.88)
SWDE84C				

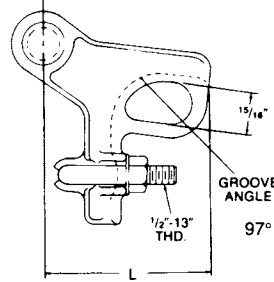
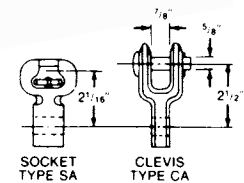

FIGURE 4



SOCKET TYPE SA
CLEVIS TYPE CA

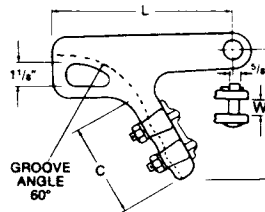

FIGURE 1

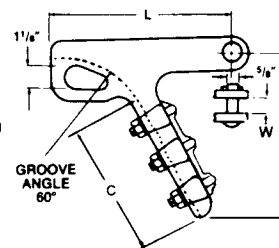

FIGURE 2

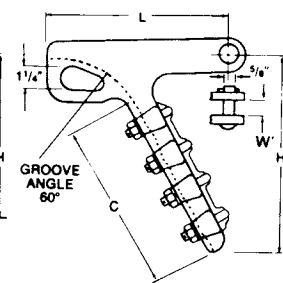

FIGURE 3

CATALOG NUMBER	FITTING		FIGURE NUMBER	CLAMPING RANGE				INCHES (MM)	ULTIMATE BODY STRENGTH LBS. (KN)	U-BOLTS		APPROX. WT. EACH LBS. (KG)
				GALV. STEEL			COPPER			NO.	SIZE INCHES (MM)	
	TYPE	CAT. NO.		DIA.	NO. STR.	GRADE						
MD52N	None	--	4	ACSR	---	---	#6 Sol.	.160-.563 (4.06-14.30)	12,000 (53)	1	1/2 (12.70)	1.9 (.86)
MD52S	Socket	SA04		#6 (6/1)								
MD52C	Clevis	CA04		4/0 (6/1)								
SWDE46N	None	--	1	3/8 (9.53)	7	Utilities High Str. Utilities	#6 Str.	.18-.46 (4.57-11.68)	15,000 (67)	2	1/2 (12.70)	4.1 (1.86)
SWDE46S	Socket	SA04		7/16 (11.11)								
SWDE46C	Clevis	CA04		3/16 (4.76)								
SWDE55N	None	--	2	1/4 (6.35)	7	All Grades Within Clamping And Strength Rating	#4 (7)	.22-.55 (5.59-13.97)	19,000 (85)	3	1/2 (12.70)	6.0 (3.08)
SWDE55S	Socket	SA04		5/16 (7.94)								
SWDE55C	Clevis	CA04		3/8 (9.53)								
				7/16 (11.11)								
SWDE84N	None	--	3	3/8 (9.53)	7	2/0 Sol.	.36-.84 (8.89-21.34)	30,000 (133)	4	1/2 (12.70)	11.0 (4.99)	
SWDE84S	Socket	SA07		thru								
SWDE84C	Clevis	CA06		3/4 (19.05)								
				7		500 Str.		25,000 (111)				12.35 (5.60)
				7								12.7 (5.76)

- NOTES:
- (1) Sag Eye Ultimate Strength is 60% of Ultimate Body Strength without fitting.
 - (2) Rated slip strength as a % of conductor RBS varies with cable size and stranding. Minimum slip strength on standard shield wire cables is 40% RBS (Partial Tension). For many shield wire cables, minimum slip strength of this clamp series is 60% RBS (Normal Tension). (Consult factory for slip strength test data on specific clamp & conductor combinations).
 - (3) Recommended torque on u-bolts: 1/2" -- 480 in-lbs.
 - (4) Bolt and Nut may be substituted for clevis pin by adding suffix "BNK" to catalog number.



DEADENDS BOLTED STRAIGHT LINE STRAIN CLAMP DUCTILE IRON

DUCTILE IRON
MDE

TA-8

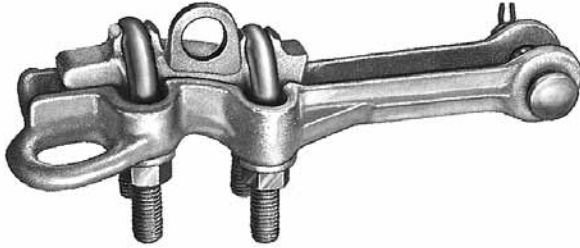

For deadending static wires.

May be used to deadend copper or Copperweld® phase conductors. Magnetic induction heating will occur.

Material: Body and Keeper—galvanized ductile iron
Hardware—galvanized steel
Sockets and Clevises—ductile iron, galvanized
Cotter Pin—#302 stainless steel

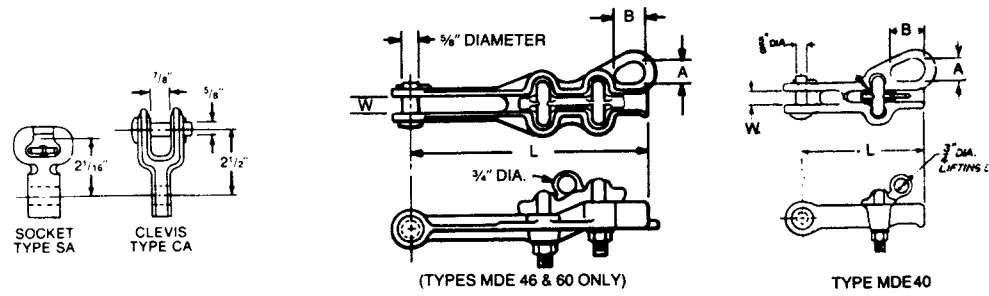

CATALOG NUMBER	FITTING		CLAMPING RANGE INCHES (MM)	ULTIMATE BODY STRENGTH LBS. (KN)	U-BOLTS		DIMENSIONS INCHES (MM)			APPROX. WT. EACH LBS. (KG)
	TYPE	CAT. NO.			NO.	SIZE INCHES (MM)	L	W	A x B	
MDE40N	None	--	.16-.40	5,000	1	1/2 (12.70)	6-3/16 (157.16)	13/16 (20.6)	7/8 x 1-1/4 (22.2 x 31.8)	2.1 (.95)
MDE40S	Socket	SA04	(4.06-10.16)	(22)						3.4 (1.54)
MDE40C	Clevis	CA04		(22)						3.7 (1.68)
MDE46N	None	--	.18-.46	6,000	2	3/8 (9.53)	7-1/2 (190.5)	3/4 (19.05)	7/8 x 1-1/4 (22.2 x 31.8)	2.5 (1.13)
MDE46S	Socket	SA04	(4.57-11.68)	(27)						3.8 (1.72)
MDE46C	Clevis	CA04		(27)						4.1 (1.86)
MDE60N	None	--	.36-.60	8,000	2	1/2 (12.70)	8-15/16 (227.01)	3/4 (19.05)	7/8 x 1-1/4 (22.2 x 31.8)	3.8 (1.72)
MDE60S	Socket	SA04	(9.14-15.24)	(36)						5.0 (2.27)
MDE60C	Clevis	CA04		(36)						5.4 (2.45)
876722000	None	--	.46-.86 (11.68-21.84)	10,000 (44)	2	1/2 (12.70)	9-1/4 (234.95)	3/4 (19.05)	1 x 1-7/16 (25.4 x 36.5)	3.8 (1.72)
876822000	None	--	.65-1.25 (16.51-31.75)	10,000 (44)	2	1/2 (12.70)	11 (279.40)	3/4 (19.05)	1 x 1-13/16 (25.4 x 36.5)	5.5 (2.49)
876922000	None	--	.86-1.55 (21.84-39.37)	10,000 (44)	2	5/8 (15.88)	12.5 (317.50)	3/4 (19.05)	1-1/18 x 2-1/8 (27.0 x 54.0)	7.9 (3.58)

- NOTES: (1) Sag Eye Ultimate Strength is 60% of Ultimate Body Strength without fitting.
 (2) Rated slip strength as a % of conductor RBS varies with cable size and stranding. Minimum slip strength on standard shield wire cables is 40% RBS (Partial Tension). (Consult factory for slip strength test data on specific clamp & conductor combinations.)
 (3) Recommended torque on u-bolts: 1/2" -- 480 in-lbs.
 (4) Bolt and Nut may be substituted for clevis pin by adding suffix "BNK" to catalog number.



DEADENDS BOLTED CIRCULAR CLAMP DUCTILE IRON

DUCTILE IRON
DDC

For deadending static wires.

May be used to deadend copper or Copperweld® phase conductors. Magnetic induction heating will occur.

Material: Body and Keeper—ductile iron, galvanized
Bolts and Washers—galvanized steel (lubricated)
Grommet—neoprene
Clevis Pin—galvanized steel
Sockets and Clevises—ductile iron, hot dip galvanized
Cotter Pin—#302 stainless steel
Spring Clip—zinc plated steel

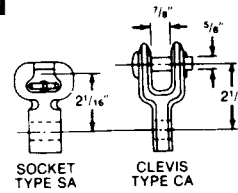

TYPE DDC

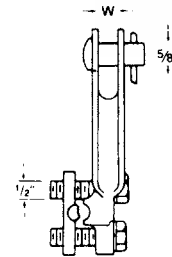
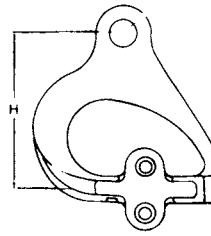

CATALOG NUMBER	FITTING		CLAMPING RANGE INCHES (MM)	ULTIMATE BODY STRENGTH LBS. (KN)	DIMENSIONS INCHES (MM)		APPROX. WT. EACH LBS. (KG)
	TYPE	CAT. NO.			W	H	
DDC55N	None	--	.16-.55	16,000	13/16	5-3/16	3.5 (1.59)
DDC55S	Socket	SA05	(4.06-13.97)	(71)	(20.64)	(131.76)	4.8 (2.18)
DDC55C	Clevis	CA05					5.1 (3.09)

CATALOG NUMBER	FITTING		CLAMPING RANGE INCHES (MM)		ULTIMATE BODY STRENGTH LBS. (KN)	DIMENSIONS INCHES (MM)		APPROX. WT. EACH LBS. (KG)
	TYPE	CAT. NO.	SMALL GROOVE	LARGE GROOVE		W	H	
805002000	None	--	.12-.19 (3.05-4.83)	.19-.38 (4.83-9.65)	8,000 (36)	11/16 (17.46)	2-7/16 (61.91)	1.5 (.68)
885002000	None	--	.20-.50 (5.08-12.70)		10,000 (44)	11/16 (17.46)	4-5/16 (109.54)	2.4 (1.09)
785002000	None	—	.16-.33	.33-.55	14,000	3/4	4-1/4	3.9 (1.77)
785012000	Socket	SA04	(4.06-8.38)	(8.38-13.97)	(62)	(19.05)	(107.95)	5.4 (2.45)



CATALOG NO. 80500



CATALOG NO. 88500



CATALOG NO. 78500

NOTE: Recommended torque on bolts; 1/2"—480 in. lbs.

DUCTILE DEADEND THIMBLE TYPE DDT

DUCTILE IRON
DDT

Provides a convenient and efficient means for loop deadending of steel static wire and formed-wire guy grips.

Material: Body—ductile iron, galvanized
Clevis Pin—galvanized steel
Cotter Pin—#302 stainless steel



CATALOG NUMBER	CONDUCTOR RANGE INCHES (MM)	ULTIMATE BODY STRENGTH LBS. (KN)	DIMENSIONS					APPROX. WT. EACH LBS.
			L	B	W	H	PD	
DDT07	0-875 (0-22.23)	40,000 (178)	5-3/8 (136.53)	2-5/16 (58.74)	7/8 (22.23)	2-1/4 (57.15)	3/4 (19)	2.5 (1.13)
DDT12*	0-1.0 (0-25.40)	60,000 (267)	7-13/16 (45.97)	3-3/4 (95.25)	1-5/16 (33.27)	3-3/4 (95.25)	1 (25)*	5.7 (2.5)

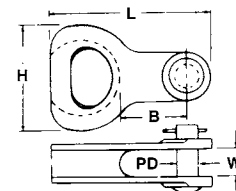

* Bolt, Nut & Cotter Pin are standard.



DEADENDS

COMPRESSION UNI-GRIP® (ONE DIE) EYE TYPE, SINGLE TONGUE ACSR CONDUCTORS

ALUMINUM/STEEL
A01/A03

TA-10

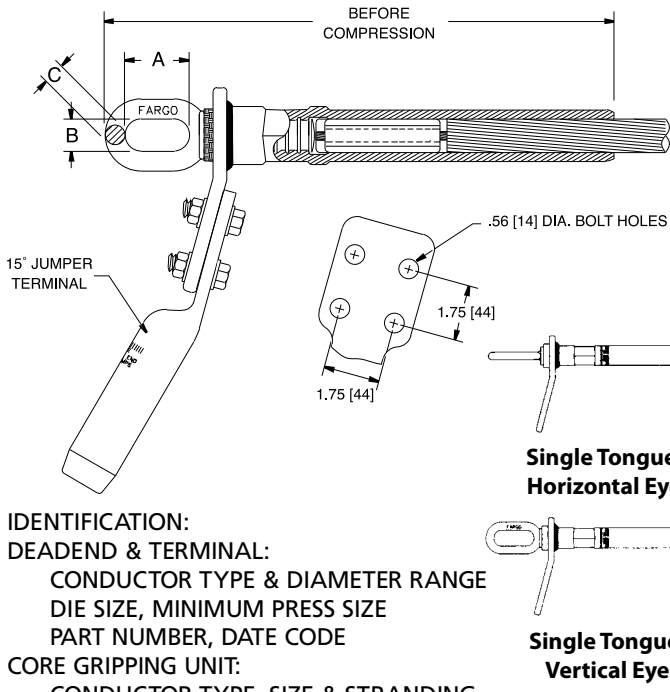

Full Tension deadend assembly for ACSR conductors consists of a prefilled aluminum deadend body precompressed onto a steel eye, a prefilled 15° jumper terminal, mounting hardware and core gripping unit. Deadend and terminal are shrink wrapped together for shipment packing.

Material: Body—Seamless extruded Aluminum Alloy tube
Eye—Galvanized forged steel
Terminal—Seamless extruded Aluminum Alloy tube
Hardware—Aluminum Alloy

- Notes: (1) For XL repair deadend add suffix "XL" and repair cutoff length in inches. Example: A0112451XL24
(2) Suffix "NT" omits jumper terminal. Example: A0112451NT
(3) Suffix "NPNT" omits both jumper terminal and deadend tongue. Example: A0112451NPNT
(4) Consult factory for Self-Dampening (SD), Trapezoidal (TW) and Metric ACSR Conductors.
(5) Deadends are EHV rated where conductor is 1.0 in. (25.4 mm) O.D. or larger.

IDENTIFICATION:
DEADEND & TERMINAL:
CONDUCTOR TYPE & DIAMETER RANGE
DIE SIZE, MINIMUM PRESS SIZE
PART NUMBER, DATE CODE
CORE GRIPPING UNIT:
CONDUCTOR TYPE, SIZE & STRANDING

VERTICAL EYE CATALOG NUMBER	HORIZONTAL EYE CATALOG NUMBER	KCMIL	STRANDING AL/ST	CODE WORD	OUTSIDE DIAMETER (IN.)	LENGTH BEFORE COMPRESSION IN (MM)	A	B	C	PAD WIDTH	BOLT HOLES	DIE SIZE	MINIMUM PRESS SIZE (TONS)
A010710	A030710	266.8	26/7	Partridge	0.642	12.2 (310)	2.0 (50)	1.0 (25)	.41 (10)	2.0 (50)	2	07CD	12
A010812	A030812	336.4	18/1	Merlin	0.684	13.2 (336)	2.0 (50)	1.0 (25)	.41 (10)	2.0 (50)	2	08CD	12
A010813	A030813	336.4	26/7	Linnet	0.72	13.2 (336)	2.0 (50)	1.0 (25)	.41 (10)	2.0 (50)	2	08CD	12
A010914	A030914	336.4	30/7	Oriole	0.741	13.2 (336)	2.0 (50)	1.0 (25)	.41 (10)	2.0 (50)	2	09CD	12
A010815	A030815	397.5	18/1	Chickadee	0.743	13.2 (336)	2.0 (50)	1.0 (25)	.41 (10)	2.0 (50)	2	08CD	12
A010917	A030917	397.5	26/7	Ibis	0.783	14.0 (356)	2.0 (50)	1.0 (25)	.52 (13)	2.0 (50)	2	09CD	12
A011018	A031018	397.5	30/7	Lark	0.806	14.9 (378)	2.0 (50)	1.0 (25)	.52 (13)	2.0 (50)	2	10CD	60
A010919	A030919	477.0	18/1	Pelican	0.814	14.0 (356)	2.0 (50)	1.0 (25)	.52 (13)	2.0 (50)	2	09CD	12
A010920	A030920	477.0	24/7	Flicker	0.846	14.0 (356)	2.0 (50)	1.0 (25)	.52 (13)	2.0 (50)	2	09CD	12
A0110211	A0310211	477.0	26/7	Hawk	0.858	14.9 (378)	2.0 (50)	1.0 (25)	.52 (13)	2.0 (50)	2	10CD	60
A011122	A031122	477.0	30/7	Hen	0.883	16.3 (413)	2.0 (50)	1.0 (25)	.62 (15)	3.0 (76)	4	11CD	60
A011023	A031023	556.5	18/1	Osprey	0.879	14.9 (378)	2.0 (50)	1.0 (25)	.52 (13)	2.0 (50)	2	10CD	60
A011024	A031024	556.5	24/7	Parakeet	0.914	14.9 (378)	2.0 (50)	1.0 (25)	.52 (13)	2.0 (50)	2	10CD	60
A011025	A031025	556.5	26/7	Dove	0.927	14.9 (378)	2.0 (50)	1.0 (25)	.52 (13)	2.0 (50)	2	10CD	60
A011126	A031126	556.5	30/7	Eagle	0.953	16.3 (413)	2.0 (50)	1.0 (25)	.62 (15)	3.0 (76)	4	11CD	60
A011127	A031127	605.0	24/7	Peacock	0.953	16.3 (413)	2.0 (50)	1.0 (25)	.62 (15)	3.0 (76)	4	11CD	60
A011128	A031128	605.0	26/7	Squab	0.966	16.3 (413)	2.0 (50)	1.0 (25)	.62 (15)	3.0 (76)	4	11CD	60
A011030	A031030	636.0	36/1	Swift	0.93	14.9 (378)	2.0 (50)	1.0 (25)	.52 (13)	2.0 (50)	2	10CD	60
A011031	A031031	636.0	18/1	Kingbird	0.94	14.9 (378)	2.0 (50)	1.0 (25)	.52 (13)	2.0 (50)	2	10CD	60



DEADENDS

COMPRESSION UNI-GRIP® (ONE DIE)

EYE TYPE, SINGLE TONGUE

ACSR CONDUCTORS (CONTINUED)

TA-11

VERTICAL EYE CATALOG NUMBER	HORIZONTAL EYE CATALOG NUMBER	KCMIL	STRANDING AL/ST	CODE WORD	OUTSIDE DIAMETER (IN.)	LENGTH BEFORE COMPRESSION IN (MM)	A	B	C	PAD WIDTH	BOLT HOLES	DIE SIZE	MINIMUM PRESS SIZE (TONS)
A011132	A031132	636.0	24/7	Rook	0.977	16.3 (413)	2.0 (50)	1.0 (25)	.62 (15)	3.0 (76)	4	11CD	60
A011133	A031133	636.0	26/7	Grosbeak	0.99	16.3 (413)	2.0 (50)	1.0 (25)	.62 (15)	3.0 (76)	4	11CD	60
A011234	A031234	636.0	30/19	Egret	1.019	17.2 (436)	2.0 (50)	1.0 (25)	.62 (15)	3.0 (76)	4	12CD	60
A011136	A031136	666.6	24/7	Flamingo	1	16.3 (413)	2.0 (50)	1.0 (25)	.62 (15)	3.0 (76)	4	11CD	60
A011137	A031137	666.6	26/7	Gannett	1.014	16.3 (413)	2.0 (50)	1.0 (25)	.62 (15)	3.0 (76)	4	11CD	60
A011138	A031138	715.5	24/7	Stilt	1.036	16.3 (413)	2.0 (50)	1.0 (25)	.62 (15)	3.0 (76)	4	11CD	60
A011239	A031239	715.5	26/7	Starling	1.051	17.2 (436)	2.0 (50)	1.0 (25)	.62 (15)	3.0 (76)	4	12CD	60
A011141	A031141	795.0	36/1	Coot	1.04	16.3 (413)	2.0 (50)	1.0 (25)	.62 (15)	3.0 (76)	4	11CD	60
A011242	A031242	795.0	45/7	Tern	1.063	17.2 (436)	2.0 (50)	1.0 (25)	.62 (15)	3.0 (76)	4	12CD	60
A0112431	A0312431	795.0	24/7	Cuckoo	1.092	17.2 (436)	2.0 (50)	1.0 (25)	.62 (15)	3.0 (76)	4	12CD	60
A0112441	A0312441	795.0	54/7	Condor	1.092	17.2 (436)	2.0 (50)	1.0 (25)	.62 (15)	3.0 (76)	4	12CD	60
A0112451	A0312451	795.0	26/7	Drake	1.108	17.2 (436)	2.0 (50)	1.0 (25)	.62 (15)	3.0 (76)	4	12CD	60
A011346	A031346	795.0	30/19	Mallard	1.14	19.6 (496)	2.5 (63)	1.2 (30)	.78 (19)	3.0 (76)	4	13CD	60
A011247	A031247	900.0	45/7	Ruddy	1.131	17.2 (436)	2.0 (50)	1.0 (25)	.62 (15)	3.0 (76)	4	12CD	60
A011348	A031348	900.0	54/7	Canary	1.162	19.6 (496)	2.5 (63)	1.2 (30)	.78 (19)	3.0 (76)	4	13CD	60
A011350	A031350	954.0	45/7	Rail	1.165	19.6 (496)	2.5 (63)	1.2 (30)	.78 (19)	3.0 (76)	4	13CD	60
A0113511	A0313511	954.0	54/7	Cardinal	1.196	19.6 (496)	2.5 (63)	1.2 (30)	.78 (19)	3.0 (76)	4	13CD	60
A011353	A031353	1033.5	45/7	Ortolan	1.212	19.6 (496)	2.5 (63)	1.2 (30)	.78 (19)	3.0 (76)	4	13CD	60
A011454	A031454	1033.5	54/7	Curlew	1.245	20.6 (522)	2.5 (63)	1.2 (30)	.78 (19)	3.0 (76)	4	14CD	60
A011455	A031455	1113.0	45/7	Bluejay	1.259	20.6 (522)	2.5 (63)	1.2 (30)	.78 (19)	3.0 (76)	4	14CD	60
A011456	A031456	1113.0	54/19	Finch	1.293	20.6 (522)	2.5 (63)	1.2 (30)	.78 (19)	3.0 (76)	4	14CD	60
A011457	A031457	1192.5	45/7	Bunting	1.302	20.6 (522)	2.5 (63)	1.2 (30)	.78 (19)	3.0 (76)	4	14CD	60
A011558	A031558	1192.5	54/19	Grackle	1.338	21.5 (545)	2.5 (63)	1.2 (30)	.78 (19)	3.0 (76)	4	15CD	60
A0115591	A0315591	1272.0	45/7	Bittern	1.345	21.5 (545)	2.5 (63)	1.2 (30)	.78 (19)	3.0 (76)	4	15CD	60
A011560	A031560	1272.0	54/19	Pheasant	1.382	21.5 (545)	2.5 (63)	1.2 (30)	.78 (19)	3.0 (76)	4	15CD	60
A011561	A031561	1351.5	45/7	Dipper	1.386	21.5 (545)	2.5 (63)	1.2 (30)	.78 (19)	3.0 (76)	4	15CD	60
A011562	A031562	1351.5	54/19	Martin	1.424	21.5 (545)	2.5 (63)	1.2 (30)	.78 (19)	3.0 (76)	4	15CD	60
A011663	A031663	1431.0	45/7	Bobolink	1.427	23.5 (596)	2.5 (63)	1.2 (30)	.94 (23)	3.0 (76)	4	16CD	60
A011667	A031667	1590.0	45/7	Lapwing	1.504	23.5 (596)	2.5 (63)	1.2 (30)	.94 (23)	3.0 (76)	4	16CD	60
A0117681	A0317681	1590.0	54/19	Falcon	1.545	24.4 (621)	2.5 (63)	1.2 (30)	.94 (23)	4.0 (101)	4	17CD	60
A011769	A031769	1780.0	84/19	Chukar	1.602	24.4 (621)	2.5 (63)	1.2 (30)	.94 (23)	4.0 (101)	4	17CD	60
A011871	A031871	2034.5	72/7	Mockingbird	1.681	25.3 (643)	2.5 (63)	1.2 (30)	.94 (23)	4.0 (101)	4	18CD	100
A011972	A031972	2156.0	84/19	Bluebird	1.762	25.3 (643)	3.0 (76)	1.5 (38)	1.1 (27)	4.0 (101)	4	19CD	100
A011973	A031973	2167.0	72/7	Kiwi	1.735	25.3 (643)	3.0 (76)	1.5 (38)	1.1 (27)	4.0 (101)	4	19CD	100
A011974	A031974	2312.0	76/19	Thrasher	1.802	25.3 (643)	3.0 (76)	1.5 (38)	1.1 (27)	4.0 (101)	4	19CD	100
A012075	A032075	2515.0	76/19	Joree	1.808	28.7 (729)	3.0 (76)	1.5 (38)	1.1 (27)	4.0 (101)	4	20CD	100



DEADENDS

COMPRESSION UNI-GRIP® (ONE DIE) EYE TYPE, DOUBLE TONGUE ACSR CONDUCTORS

ALUMINUM/STEEL
A02/A04

TA-12

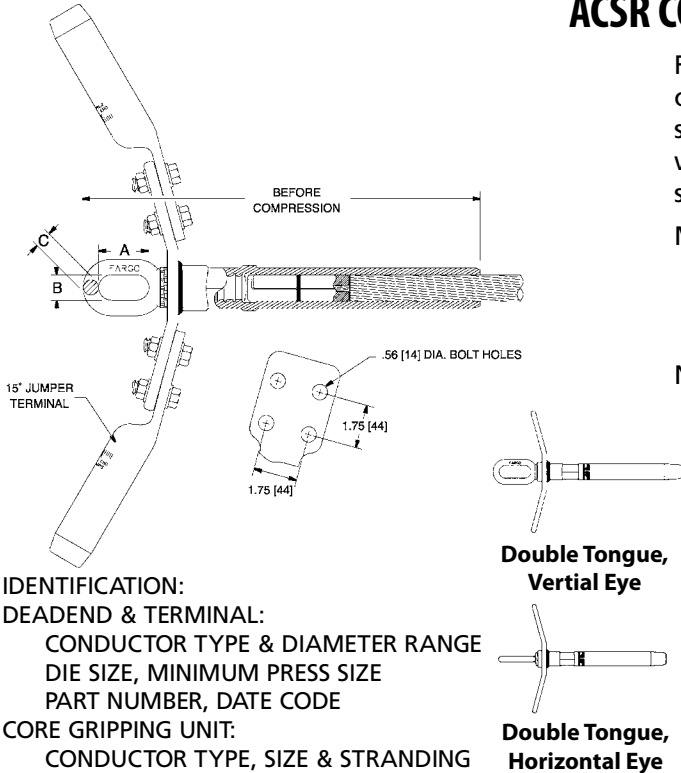

IDENTIFICATION:
DEADEND & TERMINAL:
CONDUCTOR TYPE & DIAMETER RANGE
DIE SIZE, MINIMUM PRESS SIZE
PART NUMBER, DATE CODE
CORE GRIPPING UNIT:
CONDUCTOR TYPE, SIZE & STRANDING

Full Tension deadend assembly for ACSR conductors consists of a prefilled aluminum deadend body precompressed onto a steel eye, two prefilled 15° jumper terminals, mounting hardware and core wire gripping unit. Deadend and terminal are shrink wrapped together for shipment packing.

Material: Body—Seamless extruded Aluminum Alloy tube
Eye—Galvanized forged steel
Terminal—Seamless extruded Aluminum Alloy tube
Hardware—Aluminum Alloy

- Notes: (1) For XL repair deadend add suffix "XL" and repair cutoff length in inches.
Example: A0312451XL24
(2) Suffix "NT" omits jumper terminal.
Example: A0412451NT
(3) Suffix "NPNT" omits both jumper terminal and deadend tongue.
Example: A0412451NPNT
(4) Consult factory for Self-Dampening (SD) and Trapezoidal (TW) conductors.
(5) Deadends are EHV rated where conductor is 1.0 in. (25.4 mm) O.D. or larger.

VERTICAL EYE CATALOG NUMBER	HORIZONTAL EYE CATALOG NUMBER	KCMIL	STRANDING AL/ST	CODE WORD	OUTSIDE DIAMETER (IN.)	LENGTH BEFORE COMPRESSION IN (MM)	A	B	C	PAD WIDTH	BOLT HOLES	DIE SIZE	MINIMUM PRESS SIZE (TONS)
A020710	A040710	266.8	26/7	Partridge	0.642	12.2 (310)	2.0 (50)	1.0 (25)	.41 (10)	2.0 (50)	2	07CD	12
A020812	A040812	336.4	18/1	Merlin	0.684	13.2 (336)	2.0 (50)	1.0 (25)	.41 (10)	2.0 (50)	2	08CD	12
A020813	A040813	336.4	26/7	Linnet	0.72	13.2 (336)	2.0 (50)	1.0 (25)	.41 (10)	2.0 (50)	2	08CD	12
A020914	A040914	336.4	30/7	Oriole	0.741	13.2 (336)	2.0 (50)	1.0 (25)	.41 (10)	2.0 (50)	2	09CD	12
A020815	A040815	397.5	18/1	Chickadee	0.743	13.2 (336)	2.0 (50)	1.0 (25)	.41 (10)	2.0 (50)	2	08CD	12
A020917	A040917	397.5	26/7	Ibis	0.783	14.0 (356)	2.0 (50)	1.0 (25)	.52 (13)	2.0 (50)	2	09CD	12
A021018	A041018	397.5	30/7	Lark	0.806	14.9 (378)	2.0 (50)	1.0 (25)	.52 (13)	2.0 (50)	2	10CD	60
A020919	A040919	477.0	18/1	Pelican	0.814	14.0 (356)	2.0 (50)	1.0 (25)	.52 (13)	2.0 (50)	2	09CD	60
A020920	A040920	477.0	24/7	Flicker	0.846	14.0 (356)	2.0 (50)	1.0 (25)	.52 (13)	2.0 (50)	2	09CD	60
A0210211	A0410211	477.0	26/7	Hawk	0.858	14.9 (378)	2.0 (50)	1.0 (25)	.52 (13)	2.0 (50)	2	10CD	60
A021122	A041122	477.0	30/7	Hen	0.883	16.3 (413)	2.0 (50)	1.0 (25)	.62 (15)	3.0 (76)	4	11CD	60
A021023	A041023	556.5	18/1	Osprey	0.879	14.9 (378)	2.0 (50)	1.0 (25)	.52 (13)	2.0 (50)	2	10CD	60
A021024	A041024	556.5	24/7	Parakeet	0.914	14.9 (378)	2.0 (50)	1.0 (25)	.52 (13)	2.0 (50)	2	10CD	60
A021025	A041025	556.5	26/7	Dove	0.927	14.9 (378)	2.0 (50)	1.0 (25)	.52 (13)	2.0 (50)	2	10CD	60
A021126	A041126	556.5	30/7	Eagle	0.953	16.3 (413)	2.0 (50)	1.0 (25)	.62 (15)	3.0 (76)	4	11CD	60
A021127	A041127	605.0	24/7	Peacock	0.953	16.3 (413)	2.0 (50)	1.0 (25)	.62 (15)	3.0 (76)	4	11CD	60
A021128	A041128	605.0	26/7	Squab	0.966	16.3 (413)	2.0 (50)	1.0 (25)	.62 (15)	3.0 (76)	4	11CD	60
A021030	A041030	636.0	36/1	Swift	0.93	14.9 (378)	2.0 (50)	1.0 (25)	.52 (13)	2.0 (50)	2	10CD	60
A021031	A041031	636.0	18/1	Kingbird	0.94	14.9 (378)	2.0 (50)	1.0 (25)	.52 (13)	2.0 (50)	2	10CD	60

Continued on next page



DEADENDS

COMPRESSION UNI-GRIP® (ONE DIE)

EYE TYPE, DOUBLE TONGUE

ACSR CONDUCTORS (CONTINUED)

TA-13

VERTICAL EYE CATALOG NUMBER	HORIZONTAL EYE CATALOG NUMBER	KCMIL	STRANDING AL/ST	CODE WORD	OUTSIDE DIAMETER (IN.)	LENGTH BEFORE COMPRESSION IN (MM)	A	B	C	PAD WIDTH	BOLT HOLES	DIE SIZE	MINIMUM PRESS SIZE (TONS)
A021132	A041132	636.0	24/7	Rook	0.977	16.3 (413)	2.0 (50)	1.0 (25)	.62 (15)	3.0 (76)	4	11CD	60
A021133	A041133	636.0	26/7	Grosbeak	0.99	16.3 (413)	2.0 (50)	1.0 (25)	.62 (15)	3.0 (76)	4	11CD	60
A021234	A041234	636.0	30/19	Egret	1.019	17.2 (436)	2.0 (50)	1.0 (25)	.62 (15)	3.0 (76)	4	12CD	60
A021136	A041136	666.6	24/7	Flamingo	1	16.3 (413)	2.0 (50)	1.0 (25)	.62 (15)	3.0 (76)	4	11CD	60
A021137	A041137	666.6	26/7	Gannett	1.014	16.3 (413)	2.0 (50)	1.0 (25)	.62 (15)	3.0 (76)	4	11CD	60
A021138	A041138	715.5	24/7	Stilt	1.036	16.3 (413)	2.0 (50)	1.0 (25)	.62 (15)	3.0 (76)	4	11CD	60
A021239	A041239	715.5	26/7	Starling	1.051	17.2 (436)	2.0 (50)	1.0 (25)	.62 (15)	3.0 (76)	4	12CD	60
A021141	A041141	795.0	36/1	Coot	1.04	16.3 (413)	2.0 (50)	1.0 (25)	.62 (15)	3.0 (76)	4	11CD	60
A021242	A041242	795.0	45/7	Tern	1.063	17.2 (436)	2.0 (50)	1.0 (25)	.62 (15)	3.0 (76)	4	12CD	60
A0212431	A0412431	795.0	24/7	Cuckoo	1.092	17.2 (436)	2.0 (50)	1.0 (25)	.62 (15)	3.0 (76)	4	12CD	60
A0212441	A0412441	795.0	54/7	Condor	1.092	17.2 (436)	2.0 (50)	1.0 (25)	.62 (15)	3.0 (76)	4	12CD	60
A0212451	A0412451	795.0	26/7	Drake	1.108	17.2 (436)	2.0 (50)	1.0 (25)	.62 (15)	3.0 (76)	4	12CD	60
A021346	A041346	795.0	30/19	Mallard	1.14	19.6 (496)	2.5 (63)	1.2 (30)	.78 (19)	3.0 (76)	4	13CD	60
A021247	A041247	900.0	45/7	Ruddy	1.131	17.2 (436)	2.0 (50)	1.0 (25)	.62 (15)	3.0 (76)	4	12CD	60
A021348	A041348	900.0	54/7	Canary	1.162	19.6 (496)	2.5 (63)	1.2 (30)	.78 (19)	3.0 (76)	4	13CD	60
A021350	A041350	954.0	45/7	Rail	1.165	19.6 (496)	2.5 (63)	1.2 (30)	.78 (19)	3.0 (76)	4	13CD	60
A0213511	A0413511	954.0	54/7	Cardinal	1.196	19.6 (496)	2.5 (63)	1.2 (30)	.78 (19)	3.0 (76)	4	13CD	60
A021353	A041353	1033.5	45/7	Ortolan	1.212	19.6 (496)	2.5 (63)	1.2 (30)	.78 (19)	3.0 (76)	4	13CD	60
A021454	A041454	1033.5	54/7	Curlew	1.245	20.6 (522)	2.5 (63)	1.2 (30)	.78 (19)	3.0 (76)	4	14CD	60
A021455	A041455	1113.0	45/7	Bluejay	1.259	20.6 (522)	2.5 (63)	1.2 (30)	.78 (19)	3.0 (76)	4	14CD	60
A021456	A041456	1113.0	54/19	Finch	1.293	20.6 (522)	2.5 (63)	1.2 (30)	.78 (19)	3.0 (76)	4	14CD	60
A021457	A041457	1192.5	45/7	Bunting	1.302	20.6 (522)	2.5 (63)	1.2 (30)	.78 (19)	3.0 (76)	4	14CD	60
A021558	A041558	1192.5	54/19	Grackle	1.338	21.5 (545)	2.5 (63)	1.2 (30)	.78 (19)	3.0 (76)	4	15CD	60
A0215591	A0415591	1272.0	45/7	Bittern	1.345	21.5 (545)	2.5 (63)	1.2 (30)	.78 (19)	3.0 (76)	4	15CD	60
A021560	A041560	1272.0	54/19	Pheasant	1.382	21.5 (545)	2.5 (63)	1.2 (30)	.78 (19)	3.0 (76)	4	15CD	60
A021561	A041561	1351.5	45/7	Dipper	1.386	21.5 (545)	2.5 (63)	1.2 (30)	.78 (19)	3.0 (76)	4	15CD	60
A021562	A041562	1351.5	54/19	Martin	1.424	21.5 (545)	2.5 (63)	1.2 (30)	.78 (19)	3.0 (76)	4	15CD	60
A021663	A041663	1431.0	45/7	Bobolink	1.427	23.5 (596)	2.5 (63)	1.2 (30)	.94 (23)	3.0 (76)	4	16CD	60
A021664	A041664	1431.0	54/19	Plover	1.465	23.5 (596)	2.5 (63)	1.2 (30)	.94 (23)	3.0 (76)	4	16CD	60
A021667	A041667	1590.0	45/7	Lapwing	1.504	23.5 (596)	2.5 (63)	1.2 (30)	.94 (23)	3.0 (76)	4	16CD	60
A0217681	A0417681	1590.0	54/19	Falcon	1.545	24.4 (621)	2.5 (63)	1.2 (30)	.94 (23)	4.0 (101)	4	17CD	60
A021769	A041769	1780.0	84/19	Chukar	1.602	24.4 (621)	2.5 (63)	1.2 (30)	.94 (23)	4.0 (101)	4	17CD	60
A021871	A041871	2034.5	72/7	Mockingbird	1.681	25.3 (643)	2.5 (63)	1.2 (30)	.94 (23)	4.0 (101)	4	18CD	100
A021972	A041972	2156.0	84/19	Bluebird	1.762	27.7 (704)	3.0 (76)	1.5 (38)	1.1 (27)	4.0 (101)	4	19CD	100
A021973	A041973	2167.0	72/7	Kiwi	1.735	27.7 (704)	3.0 (76)	1.5 (38)	1.1 (27)	4.0 (101)	4	19CD	100
A021974	A041974	2312.0	76/19	Thrasher	1.802	27.7 (704)	3.0 (76)	1.5 (38)	1.1 (27)	4.0 (101)	4	19CD	100
A022075	A042075	2515.0	76/19	Joree	1.808	28.7 (729)	3.0 (76)	1.5 (38)	1.1 (27)	4.0 (101)	4	20CD	100



DEADENDS

COMPRESSION UNI-GRIP® (ONE DIE)

ADJUSTABLE CLEVIS TYPE

ACSR CONDUCTORS

ALUMINUM/STEEL
A09/A10

TA-14

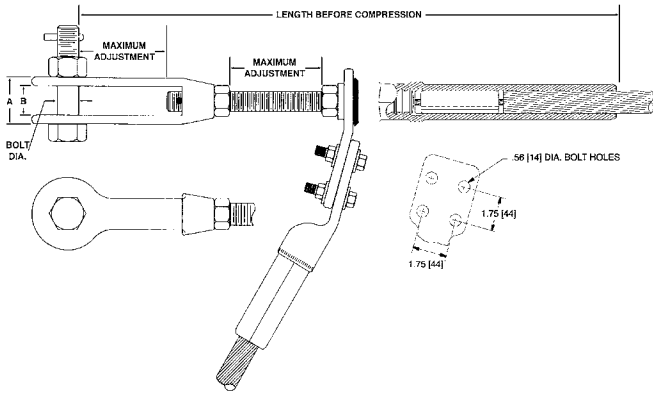

Full Tension deadend assembly for ACSR conductors consists of a prefilled aluminum deadend body precompressed onto a steel adjustable clevis. Single tongue deadends are supplied with one jumper terminal and double tongue deadends are supplied with two jumper terminals, mounting hardware and core wire gripping unit. Deadend and terminal are shrink wrapped together for shipment packing.

Material: Body—Seamless extruded Aluminum Alloy tube
 Clevis—Galvanized forged steel
 Terminal—Seamless extruded Aluminum Alloy tube
 Terminal Hardware—Aluminum Alloy
 Cotter Pin—304 Stainless Steel

IDENTIFICATION:

DEADEND & TERMINAL:

CONDUCTOR TYPE & DIAMETER RANGE
 DIE SIZE, MINIMUM PRESS SIZE
 PART NUMBER, DATE CODE

CORE GRIPPING UNIT:

CONDUCTOR TYPE, SIZE & STRANDING

- Notes:**
- (1) For XL repair deadend add suffix "XL" and repair cutoff length in inches.
Example: A0912451XL24
 - (2) Suffix "NT" omits jumper terminal.
Example: A0912451NT
 - (3) Suffix "NPNT" omits both jumper terminal and deadend tongue.
Example: A0912451NPNT
 - (4) Consult factory for Self-Dampening (SD), Trapezoidal (TW) conductors and Metric Conductors.
 - (5) Deadends are EHV rated where conductor is 1.0 in. (25.4 mm) O.D. or larger.

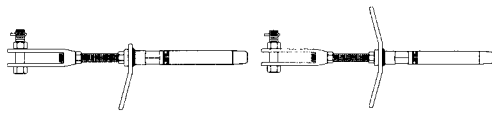

Single Tongue, Adjustable Clevis

Double Tongue, Adjustable Clevis

SINGLE TONGUE CATALOG NUMBER	DOUBLE TONGUE CATALOG NUMBER	KCMIL	STRANDING AL/ST	CODE WORD	OUTSIDE DIAMETER (IN.)	LENGTH BEFORE COMPRESSION IN (MM)	A	B	MAX ADJUST.	BOLT DIAMETER	SINGLE TONGUE PAD WIDTH	BOLT HOLES	DIE SIZE	MINIMUM PRESS SIZE (TONS)
A090812	A100812	336.4	18/1	Merlin	0.684	19.3 (491)	1.7 (43)	1.1 (28)	2.9 (73)	.62 (16)	2.0 (50)	2	08CD	12
A090813	A100813	336.4	26/7	Linnet	0.72	19.3 (491)	1.7 (43)	1.1 (28)	2.9 (73)	.62 (16)	2.0 (50)	2	08CD	12
A090914	A100914	336.4	30/7	Oriole	0.741	19.3 (491)	1.7 (43)	1.1 (28)	2.9 (73)	.62 (16)	2.0 (50)	2	09CD	12
A090815	A100815	397.5	18/1	Chickadee	0.743	19.3 (491)	1.7 (43)	1.1 (28)	2.9 (73)	.62 (16)	2.0 (50)	2	08CD	12
A090917	A100917	397.5	26/7	Ibis	0.783	20.2 (512)	1.7 (43)	1.1 (28)	2.9 (73)	.62 (16)	2.0 (50)	2	09CD	12
A091018	A101018	397.5	30/7	Lark	0.806	21.0 (534)	1.7 (43)	1.1 (28)	2.9 (73)	.75 (19)	2.0 (50)	2	10CD	60
A090919	A100919	477.0	18/1	Pelican	0.814	20.2 (512)	1.7 (43)	1.1 (28)	2.9 (73)	.62 (16)	2.0 (50)	2	09CD	12
A090920	A100920	477.0	24/7	Flicker	0.846	20.2 (512)	1.7 (43)	1.1 (28)	2.9 (73)	.62 (16)	2.0 (50)	2	09CD	12
A0910211	A1010211	477.0	26/7	Hawk	0.858	21.0 (534)	1.7 (43)	1.1 (28)	2.8 (71)	.75 (19)	2.0 (50)	2	10CD	60
A091122	A101122	477.0	30/7	Hen	0.883	24.3 (617)	2.4 (61)	1.4 (35)	3.5 (88)	1.0 (25)	3.0 (76)	4	11CD	60
A091023	A101023	556.5	18/1	Osprey	0.879	21.0 (534)	1.7 (43)	1.1 (28)	2.8 (71)	.75 (19)	2.0 (50)	2	10CD	60
A091024	A101024	556.5	24/7	Parakeet	0.914	21.0 (534)	1.7 (43)	1.1 (28)	2.8 (71)	.75 (19)	2.0 (50)	2	10CD	60
A091025	A101025	556.5	26/7	Dove	0.927	21.0 (534)	1.7 (43)	1.1 (28)	2.8 (71)	.75 (19)	2.0 (50)	2	10CD	60
A091126	A101126	556.5	30/7	Eagle	0.953	24.3 (617)	2.4 (61)	1.4 (35)	3.5 (88)	1.0 (25)	3.0 (76)	4	11CD	60
A091127	A101127	605.0	24/7	Peacock	0.953	24.3 (617)	2.4 (61)	1.4 (35)	3.5 (88)	1.0 (25)	3.0 (76)	4	11CD	60
A091128	A101128	605.0	26/7	Squab	0.966	24.3 (617)	2.4 (61)	1.4 (35)	3.5 (88)	1.0 (25)	3.0 (76)	4	11CD	60
A091030	A101030	636.0	36/1	Swift	0.93	21.0 (534)	1.7 (43)	1.1 (28)	2.8 (71)	.75 (19)	2.0 (50)	2	10CD	60

Continued on next page



DEADENDS

COMPRESSION UNI-GRIP® (ONE DIE)

ADJUSTABLE CLEVIS TYPE

ACSR CONDUCTORS (CONTINUED)

TA-15

SINGLE TONGUE CATALOG NUMBER	DOUBLE TONGUE CATALOG NUMBER	KCMIL	STRANDING AL/ST	CODE WORD	OUTSIDE DIAMETER (IN.)	LENGTH BEFORE COMPRESSION IN (MM)	A	B	MAX ADJUST.	BOLT DIAMETER	SINGLE TONGUE PAD WIDTH	BOLT HOLES	DIE SIZE	MINIMUM PRESS SIZE (TONS)
A091031	A101031	636.0	18/1	Kingbird	0.94	21.0 (534)	1.7 (43)	1.1 (28)	2.8 (71)	.75 (19)	2.0 (50)	2	10CD	60
A091132	A101132	636.0	24/7	Rook	0.977	24.3 (617)	2.4 (61)	1.4 (35)	3.5 (88)	1.0 (25)	3.0 (76)	4	11CD	60
A091133	A101133	636.0	26/7	Grosbeak	0.99	24.3 (617)	2.4 (61)	1.4 (35)	3.5 (88)	1.0 (25)	3.0 (76)	4	11CD	60
A091234	A101234	636.0	30/19	Egret	1.019	25.2 (640)	2.4 (61)	1.4 (35)	3.5 (88)	1.0 (25)	3.0 (76)	4	12CD	60
A091136	A101136	666.6	24/7	Flamingo	1	24.3 (617)	2.4 (61)	1.4 (35)	3.5 (88)	1.0 (25)	3.0 (76)	4	11CD	60
A091137	A101137	666.6	26/7	Gannett	1.014	24.3 (617)	2.4 (61)	1.4 (35)	3.5 (88)	1.0 (25)	3.0 (76)	4	11CD	60
A091138	A101138	715.5	24/7	Stilt	1.036	24.3 (617)	2.4 (61)	1.4 (35)	3.5 (88)	1.0 (25)	3.0 (76)	4	11CD	60
A091239	A101239	715.5	26/7	Starling	1.051	25.2 (640)	2.4 (61)	1.4 (35)	3.5 (88)	1.0 (25)	3.0 (76)	4	12CD	60
A091141	A101141	795.0	36/1	Coot	1.04	24.3 (617)	2.4 (61)	1.4 (35)	3.5 (88)	1.0 (25)	3.0 (76)	4	11CD	60
A091242	A101242	795.0	45/7	Tern	1.063	25.2 (640)	2.4 (61)	1.4 (35)	3.5 (88)	1.0 (25)	3.0 (76)	4	12CD	60
A0912431	A1012431	795.0	24/7	Cuckoo	1.092	25.2 (640)	2.4 (61)	1.4 (35)	3.5 (88)	1.0 (25)	3.0 (76)	4	12CD	60
A0912441	A1012441	795.0	54/7	Condor	1.092	25.2 (640)	2.4 (61)	1.4 (35)	3.5 (88)	1.0 (25)	3.0 (76)	4	12CD	60
A0912451	A1012451	795.0	26/7	Drake	1.108	25.2 (640)	2.4 (61)	1.4 (35)	3.5 (88)	1.0 (25)	3.0 (76)	4	12CD	60
A091346	A101346	795.0	30/19	Mallard	1.14	27.0 (686)	2.4 (61)	1.4 (35)	3.5 (88)	1.0 (25)	3.0 (76)	4	13CD	60
A091247	A101247	900.0	45/7	Ruddy	1.131	25.2 (640)	2.4 (61)	1.4 (35)	3.5 (88)	1.0 (25)	3.0 (76)	4	12CD	60
A091348	A101348	900.0	54/7	Canary	1.162	27.0 (686)	2.4 (61)	1.4 (35)	3.5 (88)	1.0 (25)	3.0 (76)	4	13CD	60
A091350	A101350	954.0	45/7	Rail	1.165	27.0 (686)	2.4 (61)	1.4 (35)	3.5 (88)	1.0 (25)	3.0 (76)	4	13CD	60
A0913511	A1013511	954.0	54/7	Cardinal	1.196	27.0 (686)	2.4 (61)	1.4 (35)	3.5 (88)	1.0 (25)	3.0 (76)	4	13CD	60
A091353	A101353	1033.5	45/7	Ortolan	1.212	27.0 (686)	2.4 (61)	1.4 (35)	3.5 (88)	1.0 (25)	3.0 (76)	4	13CD	60
A091454	A101454	1033.5	54/7	Curlew	1.245	28.0 (712)	2.4 (61)	1.4 (35)	3.5 (88)	1.0 (25)	3.0 (76)	4	14CD	60
A091455	A101455	1113.0	45/7	Bluejay	1.259	28.0 (712)	2.4 (61)	1.4 (35)	3.5 (88)	1.0 (25)	3.0 (76)	4	14CD	60
A091456	A101456	1113.0	54/19	Finch	1.293	28.0 (712)	2.4 (61)	1.4 (35)	3.5 (88)	1.0 (25)	3.0 (76)	4	14CD	60
A091457	A101457	1192.5	45/7	Bunting	1.302	28.0 (712)	2.4 (61)	1.4 (35)	3.5 (88)	1.0 (25)	3.0 (76)	4	14CD	60
A091558	A101558	1192.5	54/19	Grackle	1.338	33.4 (849)	2.4 (61)	1.4 (35)	3.5 (88)	1.0 (25)	3.0 (76)	4	15CD	60
A0915591	A1015591	1272.0	45/7	Bittern	1.345	33.4 (849)	2.4 (61)	1.4 (35)	3.5 (88)	1.0 (25)	3.0 (76)	4	15CD	60
A091560	A101560	1272.0	54/19	Pheasant	1.382	33.4 (849)	2.4 (61)	1.4 (35)	3.5 (88)	1.0 (25)	3.0 (76)	4	15CD	60
A091561	A101561	1351.5	45/7	Dipper	1.386	33.4 (849)	2.4 (61)	1.4 (35)	3.5 (88)	1.0 (25)	3.0 (76)	4	15CD	60
A091562	A101562	1351.5	54/19	Martin	1.424	33.4 (849)	2.4 (61)	1.4 (35)	3.5 (88)	1.0 (25)	3.0 (76)	4	15CD	60
A091663	A101663	1431.0	45/7	Bobolink	1.427	33.9 (862)	2.4 (61)	1.6 (40)	4.4 (111)	1.1 (28)	3.0 (76)	4	16CD	60
A091667	A101667	1590.0	45/7	Lapwing	1.504	33.9 (862)	2.4 (61)	1.6 (40)	4.4 (111)	1.1 (28)	3.0 (76)	4	16CD	60
A0917681	A1017681	1590.0	54/19	Falcon	1.545	35.1 (891)	2.4 (61)	1.6 (40)	4.4 (111)	1.1 (28)	4.0 (101)	4	17CD	60
A091769	A101769	1780.0	84/19	Chukar	1.602	35.1 (891)	2.4 (61)	1.6 (40)	4.4 (111)	1.1 (28)	4.0 (101)	4	17CD	60
A091871	A101871	2034.5	72/7	Mockingbird	1.681	35.8 (909)	2.4 (61)	1.6 (40)	4.4 (111)	1.1 (28)	4.0 (101)	4	18CD	100
A091972	A101972	2156.0	84/19	Bluebird	1.762	36.4 (925)	3.1 (79)	2.0 (50)	4.4 (111)	1.1 (28)	4.0 (101)	4	19CD	100
A091973	A101973	2167.0	72/7	Kiwi	1.735	36.4 (925)	3.1 (79)	2.0 (50)	4.4 (111)	1.1 (28)	4.0 (101)	4	19CD	100
A091974	A101974	2312.0	76/19	Thrasher	1.802	36.4 (925)	3.1 (79)	2.0 (50)	4.4 (111)	1.1 (28)	4.0 (101)	4	19CD	100
A092075	A102075	2515.0	76/19	Joree	1.808	37.4 (949)	3.1 (79)	2.0 (50)	4.4 (111)	1.1 (28)	4.0 (101)	4	20CD	100



DEADENDS

COMPRESSION UNI-GRIP® (ONE DIE) EYE TYPE, SINGLE TONGUE ALLOY & ACAR CONDUCTORS

ALUMINUM/STEEL
AB01/AB03

TA-16

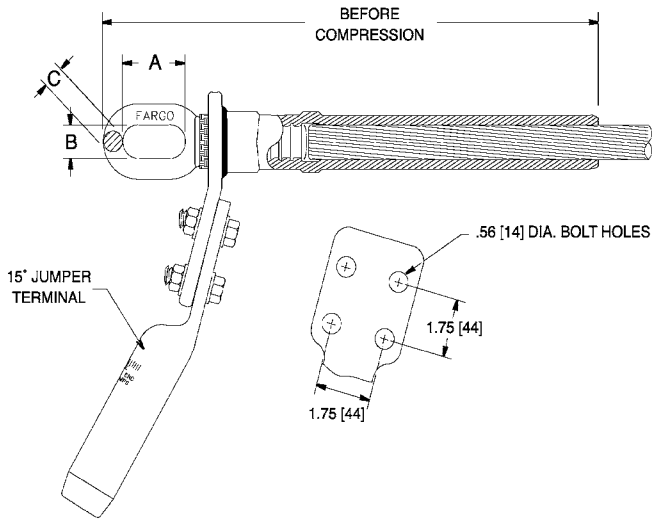

Full Tension deadend assembly for Alloy and ACAR conductors consists of a prefilled aluminum deadend body pre-compressed onto a steel eye, a prefilled 15° jumper terminal and mounting hardware. Deadend and terminal are shrink wrapped together for shipment packing.

Material: Body—Seamless extruded Aluminum Alloy tube
Eye—Galvanized forged steel
Terminal—Seamless extruded Aluminum Alloy tube
Hardware—Aluminum Alloy

- Notes:** (1) For XL repair deadend add suffix "XL" and repair cutoff length in inches.
Example: AB011212XL24
(2) Suffix "NT" omits jumper terminal.
Example: AB011212NT
(3) Suffix "NPNT" omits both jumper terminal and deadend tongue.
Example: AB011212NPNT
(4) Deadends are EHV rated where conductor is 1.0 in. (25.4 mm) O.D. or larger.

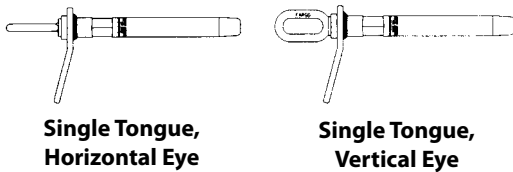

IDENTIFICATION:
DEADEND & TERMINAL:
CONDUCTOR TYPE & DIAMETER RANGE
DIE SIZE, MINIMUM PRESS SIZE
PART NUMBER, DATE CODE

VERTICAL EYE CATALOG NUMBER	HORIZONTAL EYE CATALOG NUMBER	CONDUCTOR O.D. RANGE (IN.)	AAAC / ACAR KCMIL RANGE	LENGTH BEFORE COMPRESSION IN (MM)	A	B	C	PAD WIDTH	BOLT HOLES	DIE SIZE	MINIMUM PRESS SIZE (TONS)
AB010707	AB030707	0.595-0.680	281.4-312.8	12.2 (310)	2.0 (50)	1.0 (25)	0.41 (10)	1.7 (44)	2	07CD	12
AB010808	AB030808	0.681-0.765	394.5-419.6	13.2 (336)	2.0 (50)	1.0 (25)	0.41 (10)	1.7 (44)	2	08CD	12
AB010909	AB030909	0.766-0.855	465.4-503.6	14.0 (356)	2.0 (50)	1.0 (25)	0.52 (13)	2.2 (56)	2	09CD	12
AB011010	AB031010	0.856-0.950	545.0-657.3	14.9 (378)	2.0 (50)	1.0 (25)	0.52 (13)	2.2 (56)	2	10CD	60
AB011111	AB031111	0.950-1.045	739.8-740.8	16.3 (413)	2.0 (50)	1.0 (25)	0.62 (15)	3.0 (76)	4	11CD	60
AB011212	AB031212	1.026-1.131	833.6-932.6	17.2 (436)	2.0 (50)	1.0 (25)	0.62 (15)	3.0 (76)	4	12CD	60
AB011313	AB031313	1.140-1.235	1000-1127	19.6 (496)	2.5 (63)	1.2 (30)	0.78 (19)	3.0 (76)	4	13CD	60
AB011414	AB031414	1.236-1.330	1172-1300	20.6 (523)	2.5 (63)	1.2 (30)	0.78 (19)	3.0 (76)	4	14CD	60
AB011515	AB031515	1.331-1.425	1361-1500	21.5 (546)	2.5 (63)	1.2 (30)	0.78 (19)	3.0 (76)	4	15CD	60
AB011616	AB031616	1.426-1.520	1534-1703	23.5 (597)	2.5 (63)	1.2 (30)	0.94 (23)	3.0 (76)	4	16CD	60
AB011717	AB031717	1.521-1.615	1750-1933	24.4 (620)	2.5 (63)	1.2 (30)	0.94 (23)	3.0 (76)	4	17CD	100
AB011919	AB031919	1.630-1.805	2000-2300	25.3 (643)	3.0 (76)	1.5 (38)	1.1 (27)	4.0 (101)	4	19CD	100
AB012020	AB032020	1.806-1.900	2493-2500	28.7 (729)	3.0 (76)	1.5 (38)	1.1 (27)	4.0 (101)	4	20CD	100

DEADENDS

COMPRESSION UNI-GRIP® (ONE DIE)

EYE TYPE, DOUBLE TONGUE

ALLOY & ACAR CONDUCTORS

ALUMINUM/STEEL
AB02/AB04

TA-17

Full Tension deadend assembly for Alloy and ACAR conductors consists of a prefilled aluminum deadend body precompressed onto a steel eye, two prefilled 15° jumper terminals and mounting hardware. Deadend and terminal are shrink wrapped together for shipment packing.

Material: Body—Seamless extruded Aluminum Alloy tube
 Eye—Galvanized forged steel
 Terminal—Seamless extruded Aluminum Alloy tube
 Hardware—Aluminum Alloy

- Notes:** (1) For XL repair deadend add suffix "XL" and repair cutoff length in inches.
 Example: AB041313XL24
- (2) Suffix "NT" omits jumper terminal.
 Example: AB041313NT
- (3) Suffix "NPNT" omits both jumper terminal and deadend tongue.
 Example: AB041313NPNT
- (4) Consult factory for Self-Dampening (SD) and Trapezoidal (TW) conductors.
- (5) Deadends are EHV rated where conductor is 1.0 in. (25.4 mm) O.D. or larger.

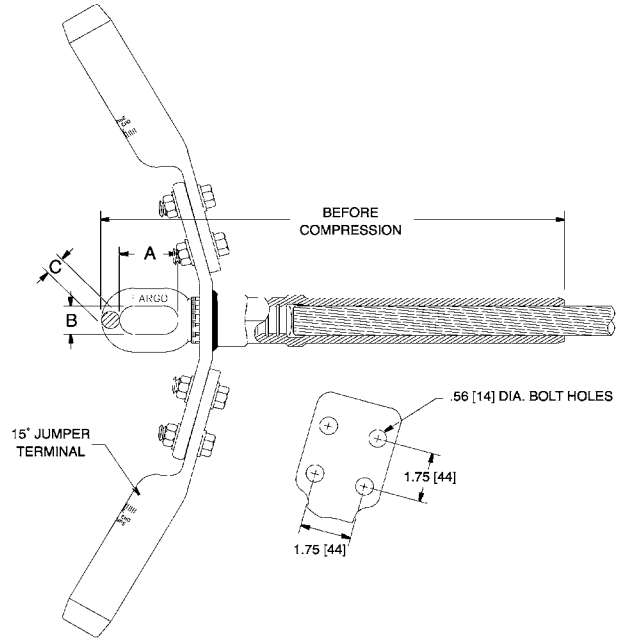

IDENTIFICATION:
DEADEND & TERMINAL:
 CONDUCTOR TYPE & DIAMETER RANGE
 DIE SIZE, MINIMUM PRESS SIZE
 PART NUMBER, DATE CODE

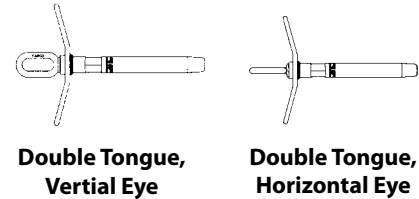

VERTICAL EYE CATALOG NUMBER	HORIZONTAL EYE CATALOG NUMBER	CONDUCTOR O.D. RANGE (IN.)	AAAC / ACAR KCMIL RANGE	LENGTH BEFORE COMPRESSION IN (MM)	A	B	C	PAD WIDTH	BOLT HOLES	DIE SIZE	MINIMUM PRESS SIZE (TONS)
AB020707	AB040707	0.595-0.680	281.4-312.8	12.2 (310)	2.0 (50)	1.0 (25)	0.41 (10)	1.7 (44)	2	07CD	12
AB020808	AB040808	0.681-0.765	394.5-419.6	13.2 (336)	2.0 (50)	1.0 (25)	0.41 (10)	1.7 (44)	2	08CD	12
AB020909	AB040909	0.766-0.855	465.4-503.6	14.0 (356)	2.0 (50)	1.0 (25)	0.52 (13)	2.2 (56)	2	09CD	12
AB021010	AB041010	0.856-0.950	545.0-657.3	14.9 (378)	2.0 (50)	1.0 (25)	0.52 (13)	2.2 (56)	2	10CD	60
AB021111	AB041111	0.950-1.045	739.8-740.8	16.3 (413)	2.0 (50)	1.0 (25)	0.62 (15)	3.0 (76)	4	11CD	60
AB021212	AB041212	1.026-1.131	833.6-932.6	17.2 (436)	2.0 (50)	1.0 (25)	0.62 (15)	3.0 (76)	4	12CD	60
AB021313	AB041313	1.140-1.235	1000-1127	19.6 (496)	2.5 (63)	1.2 (30)	0.78 (19)	3.0 (76)	4	13CD	60
AB021414	AB041414	1.236-1.330	1172-1300	20.6 (523)	2.5 (63)	1.2 (30)	0.78 (19)	3.0 (76)	4	14CD	60
AB021515	AB041515	1.331-1.425	1361-1500	21.5 (546)	2.5 (63)	1.2 (30)	0.78 (19)	3.0 (76)	4	15CD	60
AB021616	AB041616	1.426-1.520	1534-1703	23.5 (597)	2.5 (63)	1.2 (30)	0.94 (23)	3.0 (76)	4	16CD	60
AB021717	AB041717	1.521-1.615	1750-1933	24.4 (620)	2.5 (63)	1.2 (30)	0.94 (23)	3.0 (76)	4	17CD	100
AB021919	AB041919	1.630-1.805	2000-2300	25.3 (643)	3.0 (76)	1.5 (38)	1.1 (27)	4.0 (101)	4	19CD	100
AB022020	AB042020	1.806-1.900	2493-2500	28.7 (729)	3.0 (76)	1.5 (38)	1.1 (27)	4.0 (101)	4	20CD	100



DEADENDS

COMPRESSION UNI-GRIP® (ONE DIE)

ADJUSTABLE CLEVIS TYPE

ALLOY & ACAR CONDUCTORS

ALUMINUM/STEEL
AB09/AB10

TA-18

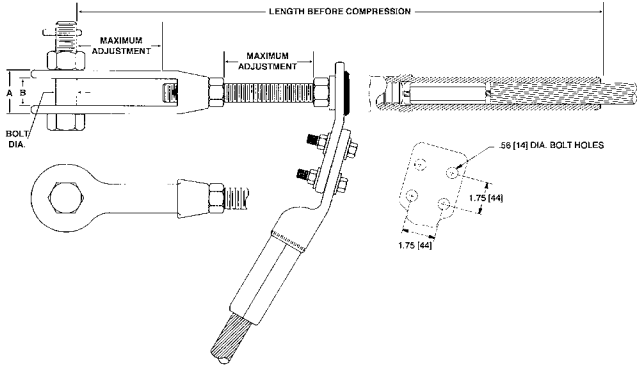

Full Tension deadend assembly for Alloy & ACAR conductors consists of a prefilled aluminum deadend body precompressed onto a steel adjustable clevis. Single tongue deadends are supplied with one jumper terminal and double tongue deadends are supplied with two jumper terminals and mounting hardware. Deadend and terminal are shrink wrapped together for shipment packing.

Material: Body—Seamless extruded Aluminum Alloy tube
 Clevis—Galvanized forged steel
 Terminal—Seamless extruded Aluminum Alloy tube
 Terminal Hardware—Aluminum Alloy
 Cotter Pin—304 Stainless Steel

IDENTIFICATION:
DEADEND & TERMINAL:
 CONDUCTOR TYPE & DIAMETER RANGE
 DIE SIZE, MINIMUM PRESS SIZE
 PART NUMBER, DATE CODE

- Notes:**
- (1) For XL repair deadend add suffix "XL" and repair cutoff length in inches.
 Example: AB091212XL24
 - (2) Suffix "NT" omits jumper terminal.
 Example: AB091212NT
 - (3) Suffix "NPNT" omits both jumper terminal and deadend tongue.
 Example: AB091212NPNT
 - (4) Deadends are EHV rated where conductor is 1.0 in. (25.4 mm) O.D. or larger.

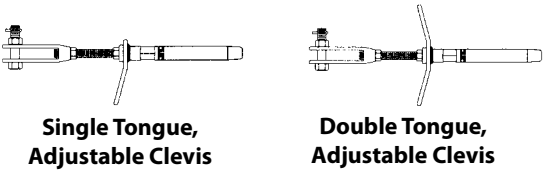

SINGLE TONGUE CATALOG NUMBER	DOUBLE TONGUE CATALOG NUMBER	CONDUCTOR O.D. RANGE (IN.)	AAAC / ACAR KCMIL RANGE	LENGTH BEFORE COMPRESSION IN (MM)	A	B	MAX. ADJUST	BOLT DIAMETER	PAD WIDTH IN (MM)	PAD BOLTS	DIE SIZE	MINIMUM PRESS SIZE (TONS)
AB090808	AB100808	0.681-0.765	394.5-419.6	19.3 (491)	1.7 (43)	1.1 (28)	2.9 (73)	0.62 (16)	1.7 (44)	2	08CD	12
AB090909	AB100909	0.766-0.855	465.4-503.6	20.2 (512)	1.7 (43)	1.1 (28)	2.9 (73)	0.62 (16)	2.2 (56)	2	09CD	12
AB091010	AB101010	0.856-0.950	545.0-657.3	21.0 (534)	1.7 (43)	1.1 (28)	2.8 (71)	0.75 (19)	2.2 (56)	2	10CD	60
AB091111	AB101111	0.950-1.045	739.8-740.8	24.3 (617)	2.4 (61)	1.4 (35)	3.5 (88)	1.0 (25)	3.0 (76)	4	11CD	60
AB091212	AB101212	1.026-1.131	833.6-932.6	25.2 (640)	2.4 (61)	1.4 (35)	3.5 (88)	1.0 (25)	3.0 (76)	4	12CD	60
AB091313	AB101313	1.140-1.235	1000-1127	27.0 (686)	2.4 (61)	1.4 (35)	3.5 (88)	1.0 (25)	3.0 (76)	4	13CD	60
AB091414	AB101414	1.236-1.330	1172-1300	28.0 (712)	2.4 (61)	1.4 (35)	3.5 (88)	1.0 (25)	3.0 (76)	4	14CD	60
AB091515	AB101515	1.331-1.425	1361-1500	33.4 (849)	2.4 (61)	1.4 (35)	3.5 (88)	1.0 (25)	3.0 (76)	4	15CD	60
AB091616	AB101616	1.426-1.520	1534-1703	33.9 (862)	2.4 (61)	1.6 (41)	4.4 (111)	1.1 (28)	3.0 (76)	4	16CD	60
AB091717	AB101717	1.521-1.615	1750-1933	35.1 (891)	2.4 (61)	1.6 (41)	4.4 (111)	1.1 (28)	3.0 (76)	4	17CD	100
AB091919	AB101919	1.630-1.805	2000-2300	36.4 (925)	3.1 (79)	2.0 (50)	4.4 (111)	1.1 (28)	4.0 (102)	4	19CD	100
AB092090	AB102020	1.806-1.900	2493-2500	37.4 (949)	3.1 (79)	2.0 (50)	4.4 (111)	1.1 (28)	4.0 (102)	4	20CD	100

DEADENDS

COMPRESSION UNI-GRIP® (ONE DIE)

EYE TYPE, SINGLE TONGUE

ALL ALUMINUM (AAC) CONDUCTORS

ALUMINUM/STEEL
C01/C03

TA-19

Full Tension deadend assembly for All Aluminum AAC conductors consists of a prefilled aluminum deadend body pre-compressed onto a steel eye, a prefilled 15° jumper terminal and mounting hardware. Deadend and terminal are shrink wrapped together for shipment packing.

Material: Body—Seamless extruded Aluminum Alloy tube
 Eye—Galvanized forged steel
 Terminal—Seamless extruded Aluminum Alloy tube
 Hardware—Aluminum Alloy

- Notes:** (1) For XL repair deadend add suffix "XL" and repair cutoff length in inches.
 Example: C011414XL18
- (2) Suffix "NT" omits jumper terminal.
 Example: C011414NT
- (3) Suffix "NPNT" omits both jumper terminal and dead-end tongue.
 Example: C01141421NPNT
- (4) Deadends are EHV rated where conductor is 1.0 in. (25.4 mm) O.D. or larger.

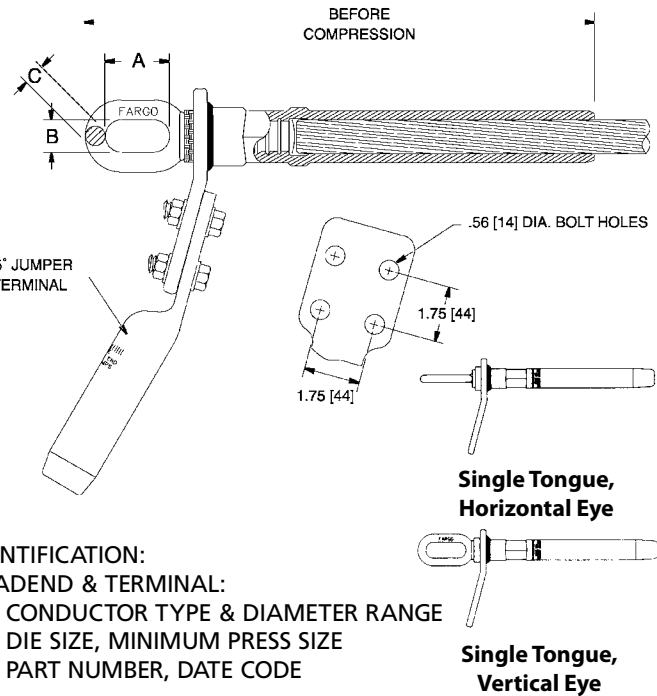

IDENTIFICATION:
DEADEND & TERMINAL:
 CONDUCTOR TYPE & DIAMETER RANGE
 DIE SIZE, MINIMUM PRESS SIZE
 PART NUMBER, DATE CODE

VERTICAL EYE CATALOG NUMBER	HORIZONTAL EYE CATALOG NUMBER	KCMIL	STRANDS	CODE WORD	OUTSIDE DIAMETER (IN.)	LENGTH BEFORE COMPRESSION IN (MM)	A	B	C	PAD WIDTH	BOLT HOLES	DIE SIZE	MINIMUM PRESS SIZE (TONS)
C010707	C030707	300.0	19	Peony	0.629	10.1 (257)	2.0 (50)	1.0 (25)	.41 (10)	2.0 (50)	2	07CD	12
C010707	C030707	336.4	19	Tulip	0.666	10.1 (257)	2.0 (50)	1.0 (25)	.41 (10)	2.0 (50)	2	07CD	12
C010707	C030707	350.0	19	Daffodil	0.679	10.1 (257)	2.0 (50)	1.0 (25)	.41 (10)	2.0 (50)	2	07CD	12
C010808	C030808	397.5	19	Canna	0.724	10.7 (272)	2.0 (50)	1.0 (25)	.41 (10)	2.0 (50)	2	08CD	12
C010808	C030808	400.0	19	Four-O'Clock	0.726	10.7 (272)	2.0 (50)	1.0 (25)	.41 (10)	2.0 (50)	2	08CD	12
C010909	C030909	450.0	19	Goldentuft	0.770	11.3 (287)	2.0 (50)	1.0 (25)	.52 (13)	2.0 (50)	2	09CD	12
C010909	C030909	450.0	37	Yarrow	0.772	11.3 (287)	2.0 (50)	1.0 (25)	.52 (13)	2.0 (50)	2	09CD	12
C010909	C030909	477.0	19	Cosmos	0.792	11.3 (287)	2.0 (50)	1.0 (25)	.52 (13)	2.0 (50)	2	09CD	12
C010909	C030909	477.0	37	Syringa	0.795	11.3 (287)	2.0 (50)	1.0 (25)	.52 (13)	2.0 (50)	2	09CD	12
C010909	C030909	500.0	19	Zinnia	0.811	11.3 (287)	2.0 (50)	1.0 (25)	.52 (13)	2.0 (50)	2	09CD	12
C010909	C030909	500.0	37	Hyacinth	0.813	11.3 (287)	2.0 (50)	1.0 (25)	.52 (13)	2.0 (50)	2	09CD	12
C010909	C030909	550.0	37	Ganzania	0.853	11.3 (287)	2.0 (50)	1.0 (25)	.52 (13)	2.0 (50)	2	09CD	12
C011010	C031010	556.5	19	Dahlia	0.856	11.9 (302)	2.0 (50)	1.0 (25)	.52 (13)	2.0 (50)	2	10CD	60
C011010	C031010	556.5	37	Mistletoe	0.858	11.9 (302)	2.0 (50)	1.0 (25)	.52 (13)	2.0 (50)	2	10CD	60
C011010	C031010	600.0	37	Meadowsweet	0.891	11.9 (302)	2.0 (50)	1.0 (25)	.52 (13)	2.0 (50)	2	10CD	60
C011010	C031010	636.0	37	Orchid	0.918	11.9 (302)	2.0 (50)	1.0 (25)	.52 (13)	2.0 (50)	2	10CD	60
C011010	C031010	650.0	37	Heuchera	0.928	11.9 (302)	2.0 (50)	1.0 (25)	.52 (13)	2.0 (50)	2	10CD	60
C011111	C031111	700.0	37	Verbena	0.963	13.0 (329)	2.0 (50)	1.0 (25)	.52 (13)	2.0 (50)	4	11CD	60
C011111	C031111	700.0	61	Flag	0.964	13.0 (329)	2.0 (50)	1.0 (25)	.52 (13)	2.0 (50)	4	11CD	60

Continued on next page



DEADENDS
COMPRESSION UNI-GRIP® (ONE DIE)
EYE TYPE, SINGLE TONGUE
ALL ALUMINUM (AAC) CONDUCTORS
(CONTINUED)

TA-20

VERTICAL EYE CATALOG NUMBER	HORIZONTAL EYE CATALOG NUMBER	KCMIL	STRANDS	CODE WORD	OUTSIDE DIAMETER (IN.)	LENGTH BEFORE COMPRESSION IN (MM)	A	B	C	PAD WIDTH	BOLT HOLES	DIE SIZE	MINIMUM PRESS SIZE (TONS)
C011111	C031111	715.5	37	Violet	0.974	13.0 (329)	2.0 (50)	1.0 (25)	.52 (13)	2.0 (50)	4	11CD	60
C011111	C031111	715.5	61	Nasturtium	0.975	13.0 (329)	2.0 (50)	1.0 (25)	.52 (13)	2.0 (50)	4	11CD	60
C011111	C031111	750.0	37	Petunia	0.997	13.0 (329)	2.0 (50)	1.0 (25)	.52 (13)	2.0 (50)	4	11CD	60
C011111	C031111	750.0	61	Cattail	0.998	13.0 (329)	2.0 (50)	1.0 (25)	.62 (15)	3.0 (76)	4	11CD	60
C011111	C031111	795.0	37	Arbutus	1.026	13.0 (329)	2.0 (50)	1.0 (25)	.62 (15)	3.0 (76)	4	11CD	60
C011111	C031111	795.0	61	Lilac	1.028	13.0 (329)	2.0 (50)	1.0 (25)	.62 (15)	3.0 (76)	4	11CD	60
C011111	C031111	800.0	37	Fuchsia	1.029	13.0 (329)	2.0 (50)	1.0 (25)	.62 (15)	3.0 (76)	4	11CD	60
C011111	C031111	800.0	61	Heliotrope	1.031	13.0 (329)	2.0 (50)	1.0 (25)	.62 (15)	3.0 (76)	4	11CD	60
C011212	C031212	874.5	37	Anemone	1.077	13.6 (344)	2.0 (50)	1.0 (25)	.62 (15)	3.0 (76)	4	12CD	60
C011212	C031212	874.5	61	Crocus	1.078	13.6 (344)	2.0 (50)	1.0 (25)	.62 (15)	3.0 (76)	4	12CD	60
C011212	C031212	900.0	37	Cockscomb	1.092	13.6 (344)	2.0 (50)	1.0 (25)	.62 (15)	3.0 (76)	4	12CD	60
C011212	C031212	900.0	61	Snapdragon	1.094	13.6 (344)	2.0 (50)	1.0 (25)	.62 (15)	3.0 (76)	4	12CD	60
C011212	C031212	954.0	37	Magnolia	1.124	13.6 (344)	2.0 (50)	1.0 (25)	.62 (15)	3.0 (76)	4	12CD	60
C011212	C031212	954.0	61	Goldenrod	1.126	13.6 (344)	2.0 (50)	1.0 (25)	.62 (15)	3.0 (76)	4	12CD	60
C011313	C031313	1000.0	37	Hawkweed	1.151	15.6 (397)	2.5 (63)	1.2 (30)	.78 (19)	3.0 (76)	4	13CD	60
C011313	C031313	1000.0	61	Camellia	1.152	15.6 (397)	2.5 (63)	1.2 (30)	.78 (19)	3.0 (76)	4	13CD	60
C011313	C031313	1033.5	37	Bluebell	1.170	15.6 (397)	2.5 (63)	1.2 (30)	.78 (19)	3.0 (76)	4	13CD	60
C011313	C031313	1033.5	61	Larkspur	1.172	15.6 (397)	2.5 (63)	1.2 (30)	.78 (19)	3.0 (76)	4	13CD	60
C011313	C031313	1113.0	61	Marigold	1.216	15.6 (397)	2.5 (63)	1.2 (30)	.78 (19)	3.0 (76)	4	13CD	60
C011414	C031414	1192.5	61	Hawthorn	1.258	16.4 (417)	2.5 (63)	1.2 (30)	.78 (19)	3.0 (76)	4	14CD	60
C011414	C031414	1272.0	61	Narcissus	1.300	16.4 (417)	2.5 (63)	1.2 (30)	.78 (19)	3.0 (76)	4	14CD	60
C011515	C031515	1351.5	61	Columbine	1.340	17.0 (431)	2.5 (63)	1.2 (30)	.78 (19)	3.0 (76)	4	15CD	60
C011515	C031515	1431.0	61	Carnation	1.379	17.0 (431)	2.5 (63)	1.2 (30)	.78 (19)	3.0 (76)	4	15CD	60
C011515	C031515	1510.5	61	Gladiolus	1.417	17.0 (431)	2.5 (63)	1.2 (30)	.78 (19)	3.0 (76)	4	15CD	60
C011616	C031616	1590.0	61	Coreopsis	1.454	18.7 (474)	2.5 (63)	1.2 (30)	.94 (23)	3.0 (76)	4	16CD	60
C011616	C031616	1590.0	91	Dogwood	1.454	18.7 (474)	2.5 (63)	1.2 (30)	.94 (23)	3.0 (76)	4	16CD	60
C011717	C031717	1750.0	61	Jessamine	1.525	19.3 (491)	2.5 (63)	1.2 (30)	.94 (23)	4.0 (101)	4	17CD	60
C011919	C031919	2000.0	91	Cowslip	1.630	22.0 (560)	3.0 (76)	1.5 (38)	1.1 (27)	4.0 (101)	4	19CD	100
C011919	C031919	2250.0	91	Sagebrush	1.729	22.0 (560)	3.0 (76)	1.5 (38)	1.1 (27)	4.0 (101)	4	19CD	100
C011919	C031919	2300.0	61	Pigweed	1.748	22.0 (560)	3.0 (76)	1.5 (38)	1.1 (27)	4.0 (101)	4	19CD	100
C012020	C032020	2500.0	91	Lupine	1.823	22.7 (577)	3.0 (76)	1.5 (38)	1.1 (27)	4.0 (101)	4	20CD	100
C012020	C032020	2750.0	91	Bitterroot	1.912	22.7 (577)	3.0 (76)	1.5 (38)	1.1 (27)	4.0 (101)	4	20CD	100

DEADENDS

COMPRESSION UNI-GRIP® (ONE DIE)

EYE TYPE, DOUBLE TONGUE

ALL ALUMINUM (AAC) CONDUCTORS

ALUMINUM/STEEL
C02/C04

TA-21

Full Tension deadend assembly for All Aluminum (AAC) conductor consists of a prefilled aluminum deadend body pre-compressed onto a steel eye, two prefilled 15° jumper terminals and mounting hardware. Deadend and terminal are shrink wrapped together for shipment packing.

Material: Body—Seamless extruded Aluminum Alloy tube
 Eye—Galvanized forged steel
 Terminal—Seamless extruded Aluminum Alloy tube
 Hardware—Aluminum Alloy

- Notes:** (1) For XL repair deadend add suffix "XL" and repair cutoff length in inches.
 Example: C041212XL18
- (2) Suffix "NT" omits jumper terminal.
 Example: C041212NT
- (3) Suffix "NPNT" omits both jumper terminal and deadend tongue.
 Example: C041212NPNT
- (4) Consult factory for Self-Dampening (SD) and Trapezoidal (TW) conductors.
- (5) Deadends are EHV rated where conductor is 1.0 in. (25.4 mm) O.D. or larger.

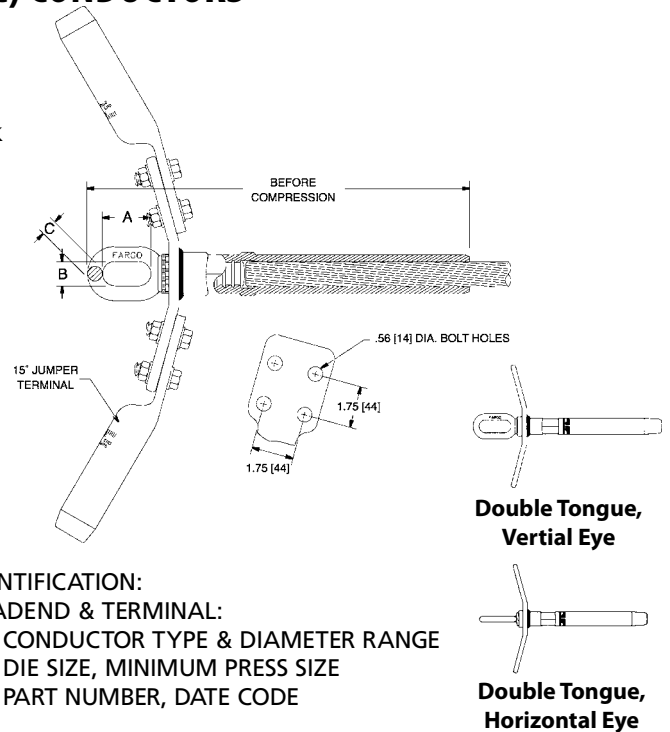

IDENTIFICATION:
 DEADEND & TERMINAL:
 CONDUCTOR TYPE & DIAMETER RANGE
 DIE SIZE, MINIMUM PRESS SIZE
 PART NUMBER, DATE CODE

VERTICAL EYE CATALOG NUMBER	HORIZONTAL EYE CATALOG NUMBER	KCMIL	STRANDS	CODE WORD	OUTSIDE DIAMETER (IN.)	LENGTH BEFORE COMPRESSION IN (MM)	A	B	C	PAD WIDTH	BOLT HOLES	DIE SIZE	MINIMUM PRESS SIZE (TONS)
C020707	C040707	300.0	19	Peony	0.629	10.1 (257)	2.0 (50)	1.0 (25)	.41 (10)	2.0 (50)	2	07CD	12
C020707	C040707	336.4	19	Tulip	0.666	10.1 (257)	2.0 (50)	1.0 (25)	.41 (10)	2.0 (50)	2	07CD	12
C020707	C040707	350.0	19	Daffodil	0.679	10.1 (257)	2.0 (50)	1.0 (25)	.41 (10)	2.0 (50)	2	07CD	12
C020808	C040808	397.5	19	Canna	0.724	10.7 (272)	2.0 (50)	1.0 (25)	.41 (10)	2.0 (50)	2	08CD	12
C020808	C040808	400.0	19	Four-O'Clock	0.726	10.7 (272)	2.0 (50)	1.0 (25)	.41 (10)	2.0 (50)	2	08CD	12
C020909	C040909	450.0	19	Goldentuft	0.770	11.3 (287)	2.0 (50)	1.0 (25)	.52 (13)	2.0 (50)	2	09CD	12
C020909	C040909	450.0	37	Yarrow	0.772	11.3 (287)	2.0 (50)	1.0 (25)	.52 (13)	2.0 (50)	2	09CD	12
C020909	C040909	477.0	19	Cosmos	0.792	11.3 (287)	2.0 (50)	1.0 (25)	.52 (13)	2.0 (50)	2	09CD	12
C020909	C040909	477.0	37	Syringa	0.795	11.3 (287)	2.0 (50)	1.0 (25)	.52 (13)	2.0 (50)	2	09CD	12
C020909	C040909	500.0	19	Zinnia	0.811	11.3 (287)	2.0 (50)	1.0 (25)	.52 (13)	2.0 (50)	2	09CD	12
C020909	C040909	500.0	37	Hyacinth	0.813	11.3 (287)	2.0 (50)	1.0 (25)	.52 (13)	2.0 (50)	2	09CD	12
C020909	C040909	550.0	37	Ganzania	0.853	11.3 (287)	2.0 (50)	1.0 (25)	.52 (13)	2.0 (50)	2	09CD	12
C021010	C041010	556.5	19	Dahlia	0.856	11.9 (302)	2.0 (50)	1.0 (25)	.52 (13)	2.0 (50)	2	10CD	60
C021010	C041010	556.5	37	Mistletoe	0.858	11.9 (302)	2.0 (50)	1.0 (25)	.52 (13)	2.0 (50)	2	10CD	60
C021010	C041010	600.0	37	Meadowsweet	0.891	11.9 (302)	2.0 (50)	1.0 (25)	.52 (13)	2.0 (50)	2	10CD	60
C021010	C041010	636.0	37	Orchid	0.918	11.9 (302)	2.0 (50)	1.0 (25)	.52 (13)	2.0 (50)	2	10CD	60
C021010	C041010	650.0	37	Heuchera	0.928	11.9 (302)	2.0 (50)	1.0 (25)	.52 (13)	2.0 (50)	2	10CD	60
C021111	C041111	700.0	37	Verbena	0.963	13.0 (329)	2.0 (50)	1.0 (25)	.62 (15)	3.0 (76)	4	11CD	60
C021111	C041111	700.0	61	Flag	0.964	13.0 (329)	2.0 (50)	1.0 (25)	.62 (15)	3.0 (76)	4	11CD	60

Continued on next page



DEADENDS
COMPRESSION UNI-GRIP® (ONE DIE)
EYE TYPE, DOUBLE TONGUE
ALL ALUMINUM (AAC) CONDUCTORS
(CONTINUED)

TA-22

VERTICAL EYE CATALOG NUMBER	HORIZONTAL EYE CATALOG NUMBER	KCMIL	STRANDS	CODE WORD	OUTSIDE DIAMETER (IN.)	LENGTH BEFORE COMPRESSION IN (MM)	A	B	C	PAD WIDTH	BOLT HOLES	DIE SIZE	MINIMUM PRESS SIZE (TONS)
C021111	C041111	715.5	37	Violet	0.974	13.0 (329)	2.0 (50)	1.0 (25)	.62 (15)	3.0 (76)	4	11CD	60
C021111	C041111	715.5	61	Nasturtium	0.975	13.0 (329)	2.0 (50)	1.0 (25)	.62 (15)	3.0 (76)	4	11CD	60
C021111	C041111	750.0	37	Petunia	0.997	13.0 (329)	2.0 (50)	1.0 (25)	.62 (15)	3.0 (76)	4	11CD	60
C021111	C041111	750.0	61	Cattail	0.998	13.0 (329)	2.0 (50)	1.0 (25)	.62 (15)	3.0 (76)	4	11CD	60
C021111	C041111	795.0	37	Arbutus	1.026	13.0 (329)	2.0 (50)	1.0 (25)	.62 (15)	3.0 (76)	4	11CD	60
C021111	C041111	795.0	61	Lilac	1.028	13.0 (329)	2.0 (50)	1.0 (25)	.62 (15)	3.0 (76)	4	11CD	60
C021111	C041111	800.0	37	Fuchsia	1.029	13.0 (329)	2.0 (50)	1.0 (25)	.62 (15)	3.0 (76)	4	11CD	60
C021111	C041111	800.0	61	Heliotrope	1.031	13.0 (329)	2.0 (50)	1.0 (25)	.62 (15)	3.0 (76)	4	11CD	60
C021212	C041212	874.5	37	Anemone	1.077	13.6 (344)	2.0 (50)	1.0 (25)	.62 (15)	3.0 (76)	4	12CD	60
C021212	C041212	874.5	61	Crocus	1.078	13.6 (344)	2.0 (50)	1.0 (25)	.62 (15)	3.0 (76)	4	12CD	60
C021212	C041212	900.0	37	Cockscomb	1.092	13.6 (344)	2.0 (50)	1.0 (25)	.62 (15)	3.0 (76)	4	12CD	60
C021212	C041212	900.0	61	Snapdragon	1.094	13.6 (344)	2.0 (50)	1.0 (25)	.62 (15)	3.0 (76)	4	12CD	60
C021212	C041212	954.0	37	Magnolia	1.124	13.6 (344)	2.0 (50)	1.0 (25)	.62 (15)	3.0 (76)	4	12CD	60
C021212	C041212	954.0	61	Goldenrod	1.126	13.6 (344)	2.0 (50)	1.0 (25)	.62 (15)	3.0 (76)	4	12CD	60
C021313	C041313	1000.0	37	Hawkweed	1.151	15.6 (397)	2.5 (63)	1.2 (30)	.78 (19)	3.0 (76)	4	13CD	60
C021313	C041313	1000.0	61	Camellia	1.152	15.6 (397)	2.5 (63)	1.2 (30)	.78 (19)	3.0 (76)	4	13CD	60
C021313	C041313	1033.5	37	Bluebell	1.170	15.6 (397)	2.5 (63)	1.2 (30)	.78 (19)	3.0 (76)	4	13CD	60
C021313	C041313	1033.5	61	Larkspur	1.172	15.6 (397)	2.5 (63)	1.2 (30)	.78 (19)	3.0 (76)	4	13CD	60
C021313	C041313	1113.0	61	Marigold	1.216	15.6 (397)	2.5 (63)	1.2 (30)	.78 (19)	3.0 (76)	4	13CD	60
C021414	C041414	1192.5	61	Hawthorn	1.258	16.4 (417)	2.5 (63)	1.2 (30)	.78 (19)	3.0 (76)	4	14CD	60
C021414	C041414	1272.0	61	Narcissus	1.300	16.4 (417)	2.5 (63)	1.2 (30)	.78 (19)	3.0 (76)	4	14CD	60
C021515	C041515	1351.5	61	Columbine	1.340	17.0 (431)	2.5 (63)	1.2 (30)	.78 (19)	3.0 (76)	4	15CD	60
C021515	C041515	1431.0	61	Carnation	1.379	17.0 (431)	2.5 (63)	1.2 (30)	.78 (19)	3.0 (76)	4	15CD	60
C021515	C041515	1510.5	61	Gladiolus	1.417	17.0 (431)	2.5 (63)	1.2 (30)	.78 (19)	3.0 (76)	4	15CD	60
C021616	C041616	1590.0	61	Coreopsis	1.454	18.7 (474)	2.5 (63)	1.2 (30)	.94 (23)	3.0 (76)	4	16CD	60
C021616	C041616	1590.0	91	Dogwood	1.454	18.7 (474)	2.5 (63)	1.2 (30)	.94 (23)	3.0 (76)	4	16CD	60
C021717	C041717	1750.0	61	Jessamine	1.525	19.3 (491)	2.5 (63)	1.2 (30)	.94 (23)	4.0 (101)	4	17CD	60
C021919	C041919	2000.0	91	Cowslip	1.630	22.0 (560)	3.0 (76)	1.5 (38)	1.1 (27)	4.0 (101)	4	19CD	100
C021919	C041919	2250.0	91	Sagebrush	1.729	22.0 (560)	3.0 (76)	1.5 (38)	1.1 (27)	4.0 (101)	4	19CD	100
C021919	C041919	2300.0	61	Pigweed	1.748	22.0 (560)	3.0 (76)	1.5 (38)	1.1 (27)	4.0 (101)	4	19CD	100
C022020	C042020	2500.0	91	Lupine	1.823	22.7 (577)	3.0 (76)	1.5 (38)	1.1 (27)	4.0 (101)	4	20CD	100
C022020	C042020	2750.0	91	Bitterroot	1.912	22.7 (577)	3.0 (76)	1.5 (38)	1.1 (27)	4.0 (101)	4	20CD	100

DEADENDS

COMPRESSION UNI-GRIP® (ONE DIE)

ADJUSTABLE CLEVIS TYPE

ALL ALUMINUM (AAC) CONDUCTORS



ALUMINUM/STEEL
C09/C10

Full Tension deadend assembly for All Aluminum (AAC) conductors consists of a prefilled aluminum deadend body precompressed onto a steel adjustable clevis. Single tongue deadends are supplied with one jumper terminal and double tongue deadends are supplied with two jumper terminals and mounting hardware. Deadend and terminal are shrink wrapped together for shipment packing.

Material: Body—Seamless extruded Aluminum Alloy tube
Clevis—Galvanized forged steel
Terminal—Seamless extruded Aluminum Alloy tube
Terminal Hardware—Aluminum Alloy
Cotter Pin—304 Stainless Steel

- Notes:** (1) For XL repair deadend add suffix "XL" and repair cutoff length in inches.
Example: C091212XL18
(2) Suffix "NT" omits jumper terminal.
Example: C091212NT
(3) Suffix "NPNT" omits both jumper terminal and deadend tongue.
Example: C091212NPNT
(4) Deadends are EHV rated where conductor is 1.0 in. (25.4 mm) O.D. or larger.

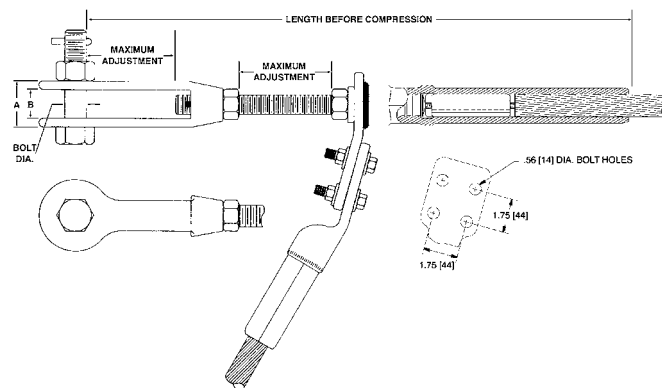

IDENTIFICATION:
DEADEND & TERMINAL:
CONDUCTOR TYPE & DIAMETER RANGE
DIE SIZE, MINIMUM PRESS SIZE
PART NUMBER, DATE CODE

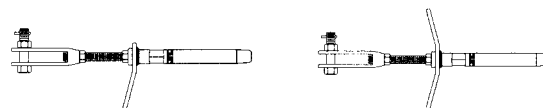

Single Tongue,
Adjustable Clevis

Double Tongue,
Adjustable Clevis

SINGLE TONGUE CATALOG NUMBER	DOUBLE TONGUE CATALOG NUMBER	KCMIL	STRANDS	CODE WORD	OUTSIDE DIAMETER (IN.)	LENGTH BEFORE COMPRESSION IN (MM)	A	B	MAX ADJUST.	BOLT DIAMETER	SINGLE TONGUE PAD WIDTH	BOLT HOLES	DIE SIZE	MINIMUM PRESS SIZE (TONS)
C090808	C100808	397.5	19	Canna	0.724	16.9 (430)	1.7 (43)	1.1 (28)	2.9 (73)	.62 (16)	2.0 (50)	2	08CD	12
C090808	C100808	400.0	19	Four-O'Clock	0.726	16.9 (430)	1.7 (43)	1.1 (28)	2.9 (73)	.62 (16)	2.0 (50)	2	08CD	12
C090909	C100909	450.0	19	Goldentuft	0.770	17.5 (444)	1.7 (43)	1.1 (28)	2.9 (73)	.62 (16)	2.0 (50)	2	09CD	12
C090909	C100909	450.0	37	Yarrow	0.772	17.5 (444)	1.7 (43)	1.1 (28)	2.9 (73)	.62 (16)	2.0 (50)	2	09CD	12
C090909	C100909	477.0	19	Cosmos	0.792	17.5 (444)	1.7 (43)	1.1 (28)	2.9 (73)	.62 (16)	2.0 (50)	2	09CD	12
C090909	C100909	477.0	37	Syringa	0.795	17.5 (444)	1.7 (43)	1.1 (28)	2.9 (73)	.62 (16)	2.0 (50)	2	09CD	12
C090909	C100909	500.0	19	Zinnia	0.811	17.5 (444)	1.7 (43)	1.1 (28)	2.9 (73)	.62 (16)	2.0 (50)	2	09CD	12
C090909	C100909	500.0	37	Hyacinth	0.813	17.5 (444)	1.7 (43)	1.1 (28)	2.9 (73)	.62 (16)	2.0 (50)	2	09CD	12
C090909	C100909	550.0	37	Ganzania	0.853	17.5 (444)	1.7 (43)	1.1 (28)	2.9 (73)	.62 (16)	2.0 (50)	2	09CD	12
C091010	C101010	556.5	19	Dahlia	0.856	18.0 (458)	1.7 (43)	1.1 (28)	2.8 (71)	.75 (19)	2.0 (50)	2	10CD	60
C091010	C101010	556.5	37	Mistletoe	0.858	18.0 (458)	1.7 (43)	1.1 (28)	2.8 (71)	.75 (19)	2.0 (50)	2	10CD	60
C091010	C101010	600.0	37	Meadowsweet	0.891	18.0 (458)	1.7 (43)	1.1 (28)	2.8 (71)	.75 (19)	2.0 (50)	2	10CD	60
C091010	C101010	636.0	37	Orchid	0.918	18.0 (458)	1.7 (43)	1.1 (28)	2.8 (71)	.75 (19)	2.0 (50)	2	10CD	60
C091010	C101010	650.0	37	Heuchera	0.928	18.0 (458)	1.7 (43)	1.1 (28)	2.8 (71)	.75 (19)	2.0 (50)	2	10CD	60
C091111	C101111	700.0	37	Verbena	0.963	21.0 (533)	2.4 (61)	1.4 (35)	3.5 (88)	1.0 (25)	3.0 (76)	4	11CD	60
C091111	C101111	700.0	61	Flag	0.964	21.0 (533)	2.4 (61)	1.4 (35)	3.5 (88)	1.0 (25)	3.0 (76)	4	11CD	60
C091111	C101111	715.5	37	Violet	0.974	21.0 (533)	2.4 (61)	1.4 (35)	3.5 (88)	1.0 (25)	3.0 (76)	4	11CD	60
C091111	C101111	715.5	61	Nasturtium	0.975	21.0 (533)	2.4 (61)	1.4 (35)	3.5 (88)	1.0 (25)	3.0 (76)	4	11CD	60

Continued on next page



DEADENDS
COMPRESSION UNI-GRIP® (ONE DIE)
ADJUSTABLE CLEVIS TYPE
ALL ALUMINUM (AAC) CONDUCTORS
(CONTINUED)

TA-24

SINGLE TONGUE CATALOG NUMBER	DOUBLE TONGUE CATALOG NUMBER	KCMIL	STRANDS	CODE WORD	OUTSIDE DIAMETER (IN.)	LENGTH BEFORE COMPRESSION IN (MM)	A	B	MAX ADJUST.	BOLT DIAMETER	SINGLE TONGUE PAD WIDTH	BOLT HOLES	DIE SIZE	MINIMUM PRESS SIZE (TONS)
C091111	C101111	750.0	37	Petunia	0.997	21.0 (533)	2.4 (61)	1.4 (35)	3.5 (88)	1.0 (25)	3.0 (76)	4	11CD	60
C091111	C101111	750.0	61	Cattail	0.998	21.0 (533)	2.4 (61)	1.4 (35)	3.5 (88)	1.0 (25)	3.0 (76)	4	11CD	60
C091111	C101111	795.0	37	Arbutus	1.026	21.0 (533)	2.4 (61)	1.4 (35)	3.5 (88)	1.0 (25)	3.0 (76)	4	11CD	60
C091111	C101111	795.0	61	Lilac	1.028	21.0 (533)	2.4 (61)	1.4 (35)	3.5 (88)	1.0 (25)	3.0 (76)	4	11CD	60
C091111	C101111	800.0	37	Fuchsia	1.029	21.0 (533)	2.4 (61)	1.4 (35)	3.5 (88)	1.0 (25)	3.0 (76)	4	11CD	60
C091111	C101111	800.0	61	Heliotrope	1.031	21.0 (533)	2.4 (61)	1.4 (35)	3.5 (88)	1.0 (25)	3.0 (76)	4	11CD	60
C091212	C101212	874.5	37	Anemone	1.077	21.6 (549)	2.4 (61)	1.4 (35)	3.5 (88)	1.0 (25)	3.0 (76)	4	12CD	60
C091212	C101212	874.5	61	Crocus	1.078	21.6 (549)	2.4 (61)	1.4 (35)	3.5 (88)	1.0 (25)	3.0 (76)	4	12CD	60
C091212	C101212	900.0	37	Cockscomb	1.092	21.6 (549)	2.4 (61)	1.4 (35)	3.5 (88)	1.0 (25)	3.0 (76)	4	12CD	60
C091212	C101212	900.0	61	Snapdragon	1.094	21.6 (549)	2.4 (61)	1.4 (35)	3.5 (88)	1.0 (25)	3.0 (76)	4	12CD	60
C091212	C101212	954.0	37	Magnolia	1.124	21.6 (549)	2.4 (61)	1.4 (35)	3.5 (88)	1.0 (25)	3.0 (76)	4	12CD	60
C091212	C101212	954.0	61	Goldenrod	1.126	21.6 (549)	2.4 (61)	1.4 (35)	3.5 (88)	1.0 (25)	3.0 (76)	4	12CD	60
C091313	C101313	1000.0	37	Hawkweed	1.151	23.1 (587)	2.4 (61)	1.4 (35)	3.5 (88)	1.0 (25)	3.0 (76)	4	13CD	60
C091313	C101313	1000.0	61	Camellia	1.152	23.1 (587)	2.4 (61)	1.4 (35)	3.5 (88)	1.0 (25)	3.0 (76)	4	13CD	60
C091313	C101313	1033.5	37	Bluebell	1.170	23.1 (587)	2.4 (61)	1.4 (35)	3.5 (88)	1.0 (25)	3.0 (76)	4	13CD	60
C091313	C101313	1033.5	61	Larkspur	1.172	23.1 (587)	2.4 (61)	1.4 (35)	3.5 (88)	1.0 (25)	3.0 (76)	4	13CD	60
C091313	C101313	1113.0	61	Marigold	1.216	23.1 (587)	2.4 (61)	1.4 (35)	3.5 (88)	1.0 (25)	3.0 (76)	4	13CD	60
C091414	C101414	1192.5	61	Hawthorn	1.258	23.8 (605)	2.4 (61)	1.4 (35)	3.5 (88)	1.0 (25)	3.0 (76)	4	14CD	60
C091414	C101414	1272.0	61	Narcissus	1.300	23.8 (605)	2.4 (61)	1.4 (35)	3.5 (88)	1.0 (25)	3.0 (76)	4	14CD	60
C091515	C101515	1351.5	61	Columbine	1.340	28.9 (735)	2.4 (61)	1.4 (35)	3.5 (88)	1.0 (25)	3.0 (76)	4	15CD	60
C091515	C101515	1431.0	61	Carnation	1.379	28.9 (735)	2.4 (61)	1.4 (35)	3.5 (88)	1.0 (25)	3.0 (76)	4	15CD	60
C091515	C101515	1510.5	61	Gladiolus	1.417	28.9 (735)	2.4 (61)	1.4 (35)	3.5 (88)	1.0 (25)	3.0 (76)	4	15CD	60
C091616	C101616	1590.0	61	Coreopsis	1.454	29.1 (740)	2.6 (66)	1.6 (40)	4.4 (111)	1.1 (28)	3.0 (76)	4	16CD	60
C091616	C101616	1590.0	91	Dogwood	1.454	29.1 (740)	2.6 (66)	1.6 (40)	4.4 (111)	1.1 (28)	3.0 (76)	4	16CD	60
C091717	C101717	1750.0	61	Jessamine	1.525	30.0 (762)	2.6 (66)	1.6 (40)	4.4 (111)	1.1 (28)	4.0 (101)	4	17CD	60
C091919	C101919	2000.0	91	Cowslip	1.630	30.7 (780)	3.1 (79)	2.0 (50)	4.4 (111)	1.1 (28)	4.0 (101)	4	19CD	100
C091919	C101919	2250.0	91	Sagebrush	1.729	30.7 (780)	3.1 (79)	2.0 (50)	4.4 (111)	1.1 (28)	4.0 (101)	4	19CD	100
C091919	C101919	2300.0	61	Pigweed	1.748	30.7 (780)	3.1 (79)	2.0 (50)	4.4 (111)	1.1 (28)	4.0 (101)	4	19CD	100
C092020	C102020	2500.0	91	Lupine	1.823	31.4 (797)	3.1 (79)	2.0 (50)	4.4 (111)	1.1 (28)	4.0 (101)	4	20CD	100
C092020	C102020	2750.0	91	Bitterroot	1.912	31.4 (797)	3.1 (79)	2.0 (50)	4.4 (111)	1.1 (28)	4.0 (101)	4	20CD	100



DEADENDS COMPRESSION CONVENTIONAL TWO-DIE SYSTEM

ALUMINUM/STEEL
SEDA/DEDA

TA-25

Full Tension deadend assemblies for ACSR and ACSS (SSAC) conductors consists of an aluminum deadend body, a steel eye, a 15° jumper terminal and mounting hardware. Terminal and tongue have NEMA hole spacing. Deadend assembly components and product label are shrink wrapped together for shipment packing.

- Material:
- Body – Seamless extruded Aluminum Alloy tube
 - Eye– Galvanized forged steel
 - Terminal–Seamless extruded Aluminum Alloy tube
 - Hardware–Aluminum Alloy

IDENTIFICATION:
CONDUCTOR SIZE, STRANDING & TYPE DIE
SIZE, MINIMUM PRESS SIZE
FARGO DATE CODE

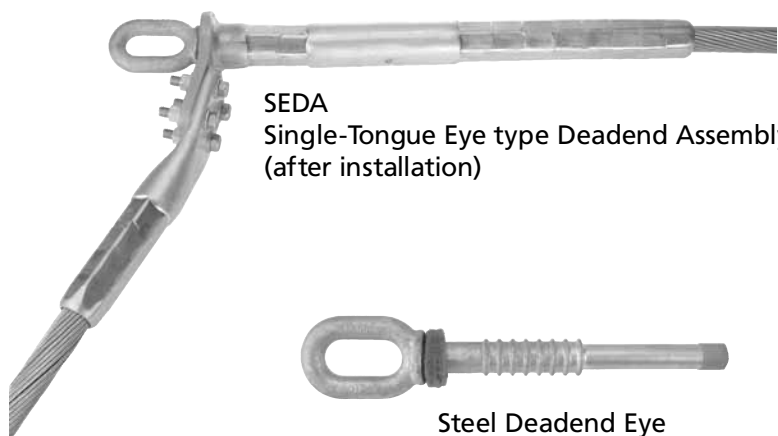

SEDA
Single-Tongue Eye type Deadend Assembly
(after installation)



Steel Deadend Eye



Deadend Body
(Single Tongue)



Jumper Terminal



DEADENDS

COMPRESSION CONVENTIONAL (2-DIE)

ACSR CONDUCTORS

ALUMINUM/STEEL
SEDA/DEDA

TA-26

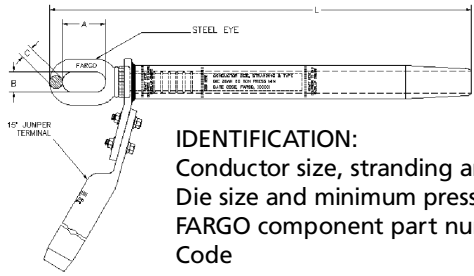

IDENTIFICATION:
 Conductor size, stranding and type
 Die size and minimum press size
 FARGO component part number Date
 Code

Full Tension deadend assemblies for ACSR conductors consist of an aluminum deadend body, steel deadend eye, 15° jumper terminal and terminal mounting hardware. Terminal and tongue have NEMA hole spacing.

Material: Body – Seamless extruded Aluminum Alloy tube
 Eye – Galvanized forged steel
 Terminal –Seamless extruded Aluminum Alloy tube
 Terminal Hardware – 1/2-13 Aluminum Alloy

SINGLE TONGUE (1) DEADEND ASSEMBLY CATALOG NUMBER	ACSR CONDUCTOR (2)			COMPONENT CATALOG NUMBER			# PAD BOLTS	DIMENSIONS (IN.) (L BEFORE COMPRESSION)				DIE SIZE(4)	
	CODE WORD	KCMIL	STRAND AL / STL	ALUMINUM BODY	STEEL EYE	TERMINAL 15°(3)		L	A	B	C	ALUM	STEEL
SEDA7829	Pigeon	3/0	6/1	12546A	133517	30546	2	15.1	2.50	1.00	0.49	75AH	75SH
SEDA7929	Penguin	4/0	6/1	12609	134520	30609	2	16.6	2.50	1.00	0.49	76AH	75SH
SEDA1102	Waxwing	266.8	18/1	12657	130114	30657	2	17.2	2.50	1.00	0.49	76AH	74SH
SEDA1109	Partridge	266.8	26/7	12688	130126	30688	2	19.3	2.50	1.00	0.49	76AH	76SH
SEDA1209	Ostrich	300.0	26/7	12740	130128	30740	2	19.9	2.50	1.00	0.49	20AH	10SH
SEDA1302	Merlin	336.4	18/1	12740	130115	30740	2	17.6	2.50	1.00	0.49	20AH	74SH
SEDA1309	Linnet	336.4	26/7	12800	130129	30800	2	20.7	2.50	1.00	0.49	20AH	10SH
SEDA1313	Oriole	336.4	30/7	12800	130234	30800	2	20.7	2.50	1.00	0.49	20AH	12SH
SEDA1502	Chickadee	397.5	18/1	12800	130117	30800	2	17.7	2.50	1.00	0.49	20AH	74SH
SEDA1508	Brant	397.5	24/7	12845	130128	30845	2	23.2	2.50	1.00	0.49	20AH	10SH
SEDA1509	Ibis	397.5	26/7	12845	130131	30845	2	23.2	2.50	1.00	0.49	20AH	10SH
SEDA1513	Lark	397.5	30/7	12845	130236	30845	2	23.2	2.50	1.00	0.49	20AH	12SH
SEDA1802	Pelican	477.0	18/1	12883	130217	30883	2	18.6	2.50	1.00	0.49	24AH	75SH
SEDA1808	Flicker	477.0	24/7	12922	130331	30922	2	19.5	2.50	1.00	0.49	24AH	10SH
SEDA1809	Hawk	477.0	26/7	12922	130234	30922	2	19.5	2.50	1.00	0.55	24AH	12SH
SEDA1813	Hen	477.0	30/7	12922	130440	30922	2	19.5	2.50	1.00	0.55	24AH	12SH
SEDA2202	Osprey	556.5	18/1	12922	130419	30922	2	19.5	2.50	1.00	0.55	24AH	75SH
SEDA2208	Parakeet	556.5	24/7	12990	130332	30990	2	19.8	2.50	1.00	0.55	24AH	10SH
SEDA2209	Dove	556.5	26/7	12990	130436	30990	2	19.8	2.50	1.00	0.55	24AH	12SH
SEDA2213	Eagle	556.5	30/7	12107C	130843	30107	4	22.5	2.62	1.00	0.67	27AH	14SH
SEDA2408	Peacock	605.0	24/7	12107	130734	30107	4	22.2	2.50	1.00	0.55	27AH	12SH
SEDA2409	Squab	605.0	26/7	12107	130737	30107	4	22.2	2.50	1.00	0.55	27AH	12SH
SEDA2413	Wood Duck	605.0	30/7	12107C	130845	30107	4	22.5	2.62	1.24	0.67	27AH	14SH
SEDA2417	Teal	605.0	30/19	12107C	130845	30107	4	22.5	2.62	1.24	0.67	27AH	14SH
SEDA2508	Rook	636.0	24/7	12107	130735	30107	4	20.5	2.50	1.00	0.55	27AH	12SH
SEDA2509	Grosbeak	636.0	26/7	12107	130739	30107	4	20.5	2.50	1.00	0.55	27AH	12SH
SEDA2513	Scoter	636.0	30/7	12107C	130846	30107	4	22.5	2.62	1.24	0.67	27AH	14SH
SEDA2517	Egret	636.0	30/19	12107C	130846	30107	4	22.5	2.62	1.24	0.67	27AH	14SH
SEDA2808	Flamingo	666.6	24/7	12107	130736	30107	4	20.5	2.50	1.00	0.55	27AH	12SH
SEDA2809	Gannet	666.6	26/7	12107	130440	30107	4	20.5	2.50	1.00	0.55	27AH	12SH
SEDA3008	Stilt	715.5	24/7	12117	131037	30117	4	23.4	2.62	1.24	0.67	30AH	12SH
SEDA3009	Starling	715.5	26/7	12117	130840	30117	4	23.4	2.62	1.24	0.67	30AH	14SH
SEDA3017	Redwing	715.5	30/19	12117	130950	30117	4	23.4	2.62	1.24	0.67	30AH	16SH
SEDA3318	Tern	795.0	45/7	12117	131429	30117	4	23.4	2.62	1.24	0.67	30AH	10SH
SEDA3308	Cuckoo	795.0	24/7	12117	131039	30117	4	23.4	2.62	1.24	0.67	30AH	12SH
SEDA3321	Condor	795.0	54/7	12117	131039	30117	4	23.4	2.62	1.24	0.67	30AH	12SH
SEDA3309	Drake	795.0	26/7	12117	130843	30117	4	23.4	2.62	1.24	0.67	30AH	14SH
SEDA3317	Mallard	795.0	30/19	12126	130951	30126	4	23.7	2.62	1.24	0.67	30AH	16SH
SEDA3721	Crane	874.5	54/7	12126	131040	30126	4	23.7	2.62	1.24	0.67	30AH	12SH
SEDA3818	Ruddy	900.0	45/7	12126	131431	30126	4	23.7	2.62	1.24	0.67	30AH	10SH

Continued on next page



DEADENDS

COMPRESSION CONVENTIONAL (2-DIE)

ACSR CONDUCTORS (CONTINUED)

TA-27

SINGLE TONGUE (1) DEADEND ASSEMBLY CATALOG NUMBER	ACSR CONDUCTOR (2)			COMPONENT CATALOG NUMBER			# PAD BOLTS	DIMENSIONS (IN.) (L BEFORE COMPRESSION)				DIE SIZE(4)	
	CODE WORD	KCMIL	STRAND AL / STL	ALUMINUM BODY	STEEL EYE	TERMINAL 15°(3)		L	A	B	C	ALUM	STEEL
SEDA3821	Canary	900.0	54/7	12126	131240	30126	4	23.7	2.62	1.24	0.67	30AH	14SH
SEDA4118	Rail	954.0	45/7	12126	131432	30126	4	23.7	2.62	1.24	0.67	30AH	10SH
SEDA4119	Towhee	954.0	48/7	12126	131036	30126	4	23.7	2.62	1.24	0.67	30AH	14SH
SEDA4121	Cardinal	954.0	54/7	12126	1308453	30126	4	23.7	2.62	1.24	0.67	30AH	14SH
SEDA4117	Canvasback	954.0	30/19	12134	132256	30132	4	27.0	2.62	1.24	0.94	34AH	18SH
SEDA4418	Ortolan	1033.5	45/7	12127	1310H328	30127	4	24.7	2.62	1.24	0.78	34AH	10SH
SEDA4421	Curlew	1033.5	54/7	12127	131243	30127	4	24.7	2.62	1.24	0.78	34AH	14SH
SEDA4718	Bluejay	1113.0	45/7	12136A	131634	30132	4	25.7	2.62	1.24	0.78	34AH	12SH
SEDA4724	Finch	1113.0	54/19	12136A	131545	30136	4	26.0	2.62	1.24	0.78	34AH	14SH
SEDA4918	Bunting	1192.5	45/7	12136A	131635	30136	4	26.0	2.62	1.24	0.78	34AH	12SH
SEDA4924	Grackle	1192.5	54/19	12141	131546	30141	4	26.6	2.62	1.24	0.78	36AH	14SH
SEDA5118	Bittern	1272.0	45/7	12141	131834	30141	4	26.6	2.62	1.24	0.78	36AH	12SH
SEDA5124	Pheasant	1272.0	54/19	12145	131950	30141	4	26.6	2.62	1.24	0.78	36AH	16SH
SEDA5218	Dipper	1351.5	45/7	12145	131837	30141	4	26.6	2.62	1.24	0.78	36AH	12SH
SEDA5224	Martin	1351.5	54/19	12151	132249	30149	4	27.1	2.62	1.24	0.94	38AH	16SH
SEDA5418	Bobolink	1431.0	45/7	12145	131839	30141	4	26.6	2.62	1.24	0.78	36AH	12SH
SEDA5424	Plover	1431.0	54/19	12151	132253	30149	4	27.1	2.62	1.24	0.94	38AH	16SH
SEDA5618	Nuthatch	1510.5	45/7	12151	132140	30149	4	27.1	2.62	1.24	0.94	38AH	12SH
SEDA5624	Parrot	1510.5	54/19	12157	132053	30157	4	29.1	2.62	1.24	0.94	40AH	16SH
SEDA5718	Lapwing	1590.0	45/7	12157	132140	30157	4	29.1	2.62	1.24	0.94	40AH	12SH
SEDA5724	Falcon	1590.0	54/19	12157	132254	30157	4	29.1	2.62	1.24	0.94	40AH	18SH
SEDA6028	Chukar	1780.0	84/19	12167	132346	30167	4	29.7	2.62	1.24	0.94	42AH	14SH
SEDA6105	Seahawk	1869.0	68/7	12167	132129	30167	4	29.7	2.62	1.24	0.94	42AH	12SH
SEDA6205	Mockingbird	2034.5	72/7	12167	132235	30167	4	29.7	2.62	1.24	0.94	42AH	14SH
SEDA6210	Roadrunner	2057.0	76/19	12167	132348	30167	4	29.7	2.62	1.24	0.94	42AH	12SH
SEDA6328	Bluebird	2156.0	84/19	12184	132450	30184	4	32.2	3.00	1.50	1.08	44AH	16SH
SEDA6425	Kiwi	2167.0	72/7	12181	132137	30181	4	32.2	3.00	1.50	1.08	44AH	12SH
SEDA6610	Thrasher	2312.0	76/19	12188	132645	30184	4	32.2	3.00	1.50	1.08	44AH	14SH

- (1) TO SPECIFY DOUBLE TONGUE DEADEND ASSEMBLY, CHANGE FIRST CHARACTER OF CATALOG NUMBER FROM "S" TO "D". TO SPECIFY DEADEND ASSEMBLY WITHOUT JUMPER TERMINAL, ADD "NT" SUFFIX TO CATALOG NUMBER.
- (2) DEADENDS ARE FULL-TENSION RATED FOR ACSR CONDUCTORS WITH STANDARD STRENGTH STEEL CORES.
- (3) 15 DEGREE JUMPER TERMINAL ALLOWS FOR 0 OR 30 DEGREE JUMPER TAKE-OFF ANGLE FROM 15 DEGREE DEADEND TONGUE. SEPARATELY ORDERED STRAIGHT TERMINALS MAY BE SPECIFIED BY CHANGING TERMINAL COMPONENT CATALOG NO. PREFIX FROM "30" TO "33".
- (4) COMPRESSION PRESS MINIMUM SIZE:
 20AH AND SMALLER - 12 TON 10SH AND SMALLER - 12 TON
 24AH THROUGH 40AH - 60 TON 12SH AND LARGER - 60 TON
 42AH AND LARGER - 100 TON
- (5) TO SPECIFY OPTIONAL STAINLESS STEEL TERMINAL HARDWARE, INCLUDING REQUIRED BELLEVILLE WASHERS, ADD "SS" SUFFIX TO CATALOG NUMBER OF DEADEND ASSEMBLY OR SEPARATELY ORDERED TERMINAL. JOINT COMPOUND: USE FARGO UJC-16 JOINT COMPOUND. OR, FOR LOWEST RESISTANCE CONNECTION, INSTALL WITH FARGO HTJC-16 COMPOUND - SEE TABLE BELOW FOR NUMBER OF 16 OZ. TUBES REQUIRED PER COMPONENT.
- (6) DEADENDS ARE EHV RATED WHERE CONDUCTOR IS 1.0 IN. (25.4 MM) O.D. OR LARGER.

FARGO Type UJC16 or HTJC16 Joint Compound required (cartridges per fitting)														
Component	Catalog Series	Die Size												
		74AH	75AH	76AH	20AH	24AH	27AH	30AH	34AH	36AH	38AH	40AH	42AH	44AH
Deadend Body	12 / 15	0.03	0.05	0.08	0.15	0.24	0.34	0.50	0.56	0.62	0.82	0.90	1.10	1.20
Jumper Terminal	30 / 33	0.03	0.03	0.03	0.04	0.06	0.07	0.10	0.14	0.16	0.18	0.22	0.25	0.30



DEADENDS

COMPRESSION CONVENTIONAL (2-DIE)

ACSS CONDUCTORS

ALUMINUM/STEEL
SEDA/DEDA-SSAC

TA-28

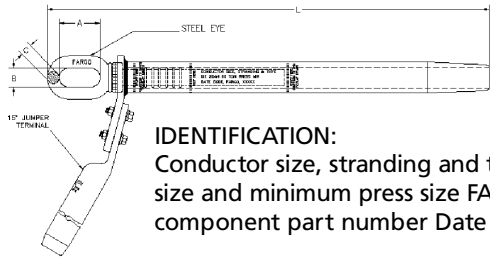

IDENTIFICATION:
Conductor size, stranding and type Die size and minimum press size FARGO component part number Date Code

Full Tension deadend assemblies for ACSS conductors consist of an aluminum deadend body, steel deadend eye, 15° jumper terminal and terminal mounting hardware. Terminal and tongue have NEMA hole spacing.

Material: Body – Seamless extruded Aluminum Alloy tube
Eye – Galvanized forged steel
Terminal – Seamless extruded Aluminum Alloy tube
Terminal Hardware – 1/2-13 Aluminum Alloy⁽⁵⁾

SINGLE TONGUE (1) DEADEND ASSEMBLY CATALOG NUMBER	ACSS CONDUCTOR (2)			COMPONENT CATALOG NUMBER			# PAD BOLTS	DIMENSIONS (IN.) (L BEFORE COMPRESSION)				DIE SIZE(4)	
	CODE WORD	KCMIL	STRAND AL / STL	ALUMINUM BODY	STEEL EYE	TERMINAL 15° (3)		L	A	B	C	ALUM	STEEL
SEDA1109SSAC	Partridge	266.8	26/7	12734SSAC	130126	30734SSAC	2	19.3	2.50	1.00	0.49	76AH	10SH
SEDA1113SSAC	Junco	266.8	30/7	12740SSAC	130131	30740SSAC	2	19.9	2.50	1.00	0.49	20AH	10SH
SEDA1209SSAC	Ostrich	300.0	26/7	12740SSAC	130128	30740SSAC	2	19.9	2.50	1.00	0.49	20AH	10SH
SEDA1309SSAC	Linnet	336.4	26/7	12800SSAC	130129	30800SSAC	2	20.7	2.50	1.00	0.49	20AH	12SH
SEDA1313SSAC	Oriole	336.4	30/7	12800SSAC	130232	30800SSAC	2	20.7	2.50	1.00	0.49	20AH	12SH
SEDA1508SSAC	Brant	397.5	24/7	12845SSAC	130128	30845SSAC	2	23.2	2.50	1.00	0.49	20AH	10SH
SEDA1509SSAC	Ibis	397.5	26/7	12845SSAC	1302301	30845SSAC	2	23.2	2.50	1.00	0.49	20AH	12SH
SEDA1513SSAC	Lark	397.5	30/7	12845SSAC	130236	30845SSAC	2	23.2	2.50	1.00	0.49	20AH	12SH
SEDA1808SSAC	Flicker	477.0	24/7	12922SSAC	130235	30922SSAC	2	24.2	2.50	1.00	0.49	24AH	12SH
SEDA1809SSAC	Hawk	477.0	26/7	12922SSAC	130234	30922SSAC	2	24.3	2.50	1.00	0.55	24AH	12SH
SEDA1813SSAC	Hen	477.0	30/7	12922SSAC	130841	30922SSAC	2	24.7	2.62	1.24	0.67	24AH	14SH
SEDA2208SSAC	Parakeet	556.5	24/7	12990SSAC	130233	30990SSAC	2	25.0	2.50	1.00	0.55	24AH	12SH
SEDA2209SSAC4	Dove	556.5	26/7	12102SSAC	131037	30107SSAC	4	26.1	2.62	1.24	0.67	27AH	12SH
SEDA2213SSAC	Eagle	556.5	30/7	12102SSAC	130843	30107SSAC	4	26.1	2.62	1.24	0.67	27AH	14SH
SEDA2408SSAC	Peacock	605.0	24/7	12107SSAC	130234	30107SSAC	4	25.7	2.50	1.00	0.55	27AH	12SH
SEDA2409SSAC	Squab	605.0	26/7	12102SSAC	130849	30107SSAC	4	26.1	2.62	1.24	0.67	27AH	14SH
SEDA2213SSAC	Wood Duck	605.0	30/7	12102SSAC	130952	30107SSAC	4	26.1	2.62	1.24	0.67	27AH	16SH
SEDA2417SSAC	Teal	605.0	30/19	12102SSAC	130952	30107SSAC	4	26.1	2.62	1.24	0.67	27AH	16SH
SEDA2508SSAC	Rook	636.0	24/7	12107SSAC	130735	30107SSAC	4	25.7	2.50	1.00	0.55	27AH	12SH
SEDA2509SSAC	Grosbeak	636.0	26/7	12102SSAC	130839	30107SSAC	4	26.1	2.62	1.24	0.67	27AH	14SH
SEDA2513SSAC	Scoter	636.0	30/7	12102SSAC	130953	30107SSAC	4	26.1	2.62	1.24	0.67	27AH	16SH
SEDA2517SSAC	Egret	636.0	30/19	12102SSAC	130953	30107SSAC	4	26.1	2.62	1.24	0.67	27AH	16SH
SEDA2808SSAC	Flamingo	666.0	24/7	12107SSAC	130735	30107SSAC	4	25.7	2.50	1.00	0.55	27AH	12SH
SEDA2809SSAC	Gannet	666.0	26/7	12107SSAC	130841	30107SSAC	4	26.1	2.62	1.24	0.67	27AH	14SH
SEDA3008SSAC	Stilt	715.5	24/7	12110SSAC	130848	30117SSAC	4	27.4	2.62	1.24	0.67	30AH	14SH
SEDA3009SSAC	Starling	715.5	26/7	12110SSAC	131242	30117SSAC	4	27.4	2.62	1.24	0.67	30AH	14SH
SEDA3017SSAC	Redwing	715.5	30/19	12110SSAC	130950	30117SSAC	4	27.4	2.62	1.24	0.67	30AH	16SH
SEDA3318SSAC	Tern	795.0	45/7	12110SSAC	131030	30117SSAC	4	27.4	2.62	1.24	0.67	30AH	12SH
SEDA3308SSAC	Cuckoo	795.0	24/7	12110SSAC	131242	30117SSAC	4	27.4	2.62	1.24	0.67	30AH	14SH
SEDA3321SSAC	Condor	795.0	54/7	12117SSAC	131242	30117SSAC	4	27.4	2.62	1.24	0.67	30AH	14SH
SEDA3309SSAC	Drake	795.0	26/7	12122SSAC	130952	30126SSAC	4	28.0	2.62	1.24	0.67	30AH	16SH
SEDA3317SSAC	Mallard	795.0	30/19	12122SSAC	130951	30126SSAC	4	28.0	2.62	1.24	0.67	30AH	16SH
SEDA3818SSAC	Ruddy	900.0	45/7	12126SSAC	131032	30126SSAC	4	28.0	2.62	1.24	0.67	30AH	12SH
SEDA3821SSAC	Canary	900.0	54/7	12126SSAC	131242	30126SSAC	4	28.0	2.62	1.24	0.67	30AH	14SH
SEDA4118SSAC	Rail	954.0	45/7	12126SSAC	131032	30126SSAC	4	28.0	2.62	1.24	0.67	30AH	12SH
SEDA4119SSAC	Towhee	954.0	48/7	12126SSAC	130847	30126SSAC	4	28.0	2.62	1.24	0.67	30AH	14SH
SEDA4121SSAC	Cardinal	954.0	54/7	12126SSAC	130952	30126SSAC	4	28.0	2.62	1.24	0.67	30AH	16SH
SEDA4117SSAC	Canvasback	954.0	30/19	12134SSAC	132256	30132SSAC	4	31.4	2.62	1.24	0.94	34AH	18SH
SEDA4418SSAC	Ortolan	1033.5	45/7	12132SSAC	131632	30132SSAC	4	29.9	2.62	1.24	0.78	34AH	12SH
SEDA4421SSAC	Curlew	1033.5	54/7	12133SSAC	131948	30132SSAC	4	30.1	2.62	1.24	0.78	34AH	16SH

Continued on next page



DEADENDS

COMPRESSION CONVENTIONAL (2-DIE)

ACSS CONDUCTORS (CONTINUED)

TA-29

SINGLE TONGUE ⁽¹⁾ DEADEND ASSEMBLY CATALOG NUMBER	ACSS CONDUCTOR ⁽²⁾			COMPONENT CATALOG NUMBER			# PAD BOLTS	DIMENSIONS (IN.) (L BEFORE COMPRESSION)				DIE SIZE ⁽⁴⁾	
	CODE WORD	KCMIL	STRAND AL / STL	ALUMINUM BODY	STEEL EYE	TERMINAL 15° ⁽³⁾		L	A	B	C	ALUM	STEEL
SEDA4718SSAC	Bluejay	1113.0	45/7	12133SSAC	131634	30132SSAC	4	30.1	2.62	1.24	0.78	34AH	12SH
SEDA4724SSAC	Finch	1113.0	54/19	12136SSAC	131949	30136SSAC	4	31.0	2.62	1.24	0.78	34AH	16SH
SEDA4918SSAC	Bunting	1192.5	45/7	12136SSAC	131541	30136SSAC	4	31.0	2.62	1.24	0.78	34AH	14SH
SEDA4924SSAC	Grackle	1192.5	54/19	12136SSAC	131949	30136SSAC	4	31.0	2.62	1.24	0.78	34AH	16SH
SEDA5118SSAC	Bittern	1272.0	45/7	12145SSAC	131541	30145SSAC	4	31.8	2.62	1.24	0.78	36AH	14SH
SEDA5124SSAC	Pheasant	1272.0	54/19	12141SSAC	132250	30145SSAC	4	32.1	2.62	1.24	0.94	36AH	18SH
SEDA5218SSAC	Dipper	1351.5	45/7	12145SSAC	131540	30145SSAC	4	31.8	2.62	1.24	0.78	36AH	14SH
SEDA5224SSAC	Martin	1351.5'	54/19	12151SSAC	132250	30149SSAC	4	33.9	2.62	1.24	0.94	38AH	18SH
SEDA5418SSAC	Bobolink	1431.0	45/7	12151SSAC	1323391	30149SSAC	4	33.9	2.62	1.24	0.94	38AH	14SH
SEDA5424SSAC	Plover	1431.0	54/19	12151SSAC	132251	30149SSAC	4	33.9	2.62	1.24	0.94	38AH	18SH
SEDA5618SSAC	Nuthatch	1510.5	45/7	12151SSAC	132041	30149SSAC	4	33.9	2.62	1.24	0.94	38AH	16SH
SEDA5624SSAC	Parrot	1510.5	54/19	12157SSAC	132252	30157SSAC	4	34.9	2.62	1.24	0.94	40AH	18SH
SEDA5718SSAC	Lapwing	1590.0	45/7	12157SSAC	132042	30157SSAC	4	34.9	2.62	1.24	0.94	40AH	16SH
SEDA5724SSAC	Falcon	1590.0	54/19	12157SSAC	132254	30157SSAC	4	34.9	2.62	1.24	0.94	40AH	18SH
SEDA6028SSAC	Chukar	1780.0	84/19	12167SSAC	132248	30167SSAC	4	35.8	2.62	1.24	0.94	42AH	16SH
SEDA6210SSAC	Roadrunner	2057.0	76/19	12167SSAC	132043	30167SSAC	4	35.8	2.62	1.24	0.94	42AH	16SH
SEDA6328SSAC	Bluebird	2156.0	84/19	12184SSAC	1327516	30184SSAC	4	39.0	3.00	1.50	1.08	44AH	18SH
SEDA6610SSAC	Thrasher	2312.0	76/19	12184SSAC	132701	30184SSAC	4	39.0	3.00	1.50	1.08	44AH	18SH

- (1) TO SPECIFY DOUBLE TONGUE DEADEND ASSEMBLY, CHANGE FIRST CHARACTER OF CATALOG NUMBER FROM "S" TO "D". TO SPECIFY DEADEND ASSEMBLY WITHOUT JUMPER TERMINAL, ADD "NT" SUFFIX TO CATALOG NUMBER.
- (2) DEADENDS ARE FULL-TENSION RATED FOR ACSS CONDUCTORS WITH STANDARD, HIGH-STRENGTH (HS) AND (EHS/UHS) STEEL CORES.
- (3) 15 DEGREE JUMPER TERMINAL ALLOWS FOR 0 OR 30 DEGREE JUMPER TAKE-OFF ANGLE FROM 15 DEGREE DEADEND TONGUE. SEPARATELY ORDERED STRAIGHT TERMINALS MAY BE SPECIFIED BY CHANGING TERMINAL COMPONENT CATALOG NO. PREFIX FROM "30" TO "33".
- (4) COMPRESSION PRESS MINIMUM SIZE:
 20AH AND SMALLER - 12 TON 10SH AND SMALLER - 12 TON
 24AH THROUGH 40AH - 60 TON 20SH AND LARGER - 60 TON
 42AH AND LARGER - 100 TON
- (5) TO SPECIFY OPTIONAL STAINLESS STEEL TERMINAL HARDWARE, INCLUDING REQUIRED BELLEVILLE WASHERS, ADD "SS" SUFFIX TO CATALOG NUMBER OF DEADEND ASSEMBLY OR SEPARATELY ORDERED TERMINAL. JOINT COMPOUND: FITTINGS ARE ACSS-RATED WHEN INSTALLED WITH FARGO HTJC-16 JOINT COMPOUND - SEE TABLE BELOW FOR NUMBER OF 16 OZ. TUBES REQUIRED FOR DEADEND BODY AND TERMINAL COMPONENTS.
- (6) DEADENDS ARE EHV RATED WHERE CONDUCTOR IS 1.0 IN. (25.4 MM) O.D. OR LARGER.
- (7) DEADENDS ARE RATED FULL-TENSION ON ACSS CONDUCTORS WITH STEEL CORE STRENGTHS MA5 & LOWER.

FARGO Type HTJC-16 Joint Compound required (cartridges per fitting)												
Component	Catalog Series	Die Size										
		76AH	20AH	24AH	27AH	30AH	34AH	36AH	38AH	40AH	42AH	44AH
Deadend Body	12 / 15	0.08	0.15	0.24	0.34	0.50	0.56	0.62	0.82	0.90	1.10	1.20
Jumper Terminal	30 / 33	0.03	0.04	0.06	0.07	0.10	0.14	0.16	0.18	0.22	0.25	0.30



DEADENDS

COMPRESSION CONVENTIONAL (2-DIE) ACSS/TW CONDUCTORS

ALUMINUM/STEEL
SEDA/DEDA-STW

TA-30

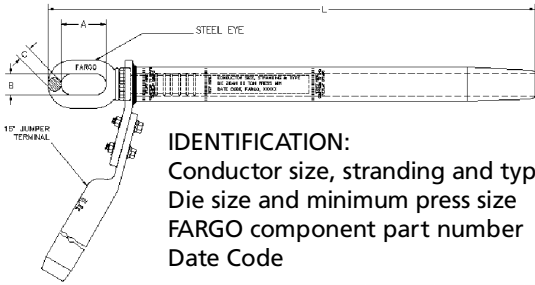

IDENTIFICATION:

Conductor size, stranding and type
Die size and minimum press size
FARGO component part number
Date Code

Full Tension deadend assemblies for ACSS conductors consist of an aluminum deadend body, steel deadend eye, 15° jumper terminal and terminal mounting hardware. Terminal and tongue have NEMA hole spacing.

Material: Body – Seamless extruded Aluminum Alloy tube
Eye – Galvanized forged steel
Terminal –Seamless extruded Aluminum Alloy tube
Terminal Hardware – 1/2-13 Aluminum Alloy⁽⁵⁾

SINGLE TONGUE (1) DEADEND ASSEMBLY CATALOG NUMBER	ACSS CONDUCTOR (2)				COMPONENT CATALOG NUMBER			# PAD BOLTS	DIMENSIONS (IN.) (L BEFORE COMPRESSION)				DIE SIZE(4)	
	CODE WORD	KCMIL	TYPE	STRAND AL/STL	ALUMINUM BODY	STEEL EYE	TERMINAL 15° (3)		L	A	B	C	ALUM	STEEL
SEDA1323STW	Oriole/TW	336.4	23	16/7	12800STW	130232	30800STW	2	19.6	2.50	1.00	0.49	20AH	12SH
SEDA1813STW	Flicker/TW	477.0	13	18/7	12922STW	130235	30922STW	2	24.0	2.50	1.00	0.49	24AH	12SH
SEDA1816STW	Hawk/TW	477.0	16	18/7	12922STW	130234	30922STW	2	24.0	2.50	1.00	0.55	24AH	12SH
SEDA1823STW	Hen/TW	477.0	23	16/7	12922STW	130841	30922STW	2	24.0	2.50	1.00	0.55	24AH	14SH
SEDA2213STW	Parakeet/TW	556.5	13	18/7	12990STW	130233	30990STW	2	24.6	2.50	1.00	0.55	24AH	12SH
SEDA2216STW4	Dove/TW	556.5	16	20/7	12102STW	131037	30102STW	4	25.6	2.62	1.24	0.67	27AH	12SH
SEDA0216STW4	Calumet	565.3	16	20/7	12102STW	131037	30102STW	4	25.6	2.62	1.24	0.67	27AH	12SH
SEDA0113STW	Mohawk	571.7	13	18/7	12102STW	131034	30102STW	4	25.6	2.62	1.24	0.67	27AH	12SH
SEDA2513STW	Rook/TW	636.0	13	18/7	12107STW	130735	30102STW	4	25.3	2.50	1.00	0.55	27AH	12SH
SEDA2516STW	Grosbeak/TW	636.0	16	20/7	12102STW	130839	30102STW	4	25.6	2.62	1.24	0.67	27AH	14SH
SEDA0416STW	Oswego	664.6	16	20/7	12102STW	130839	30102STW	4	25.6	2.62	1.24	0.67	27AH	14SH
SEDA0313STW	Mystic	666.6	13	20/7	12107STW	130237	30102STW	4	25.6	2.62	1.00	0.55	27AH	12SH
SEDA0513STW	Maumee	762.8	13	20/7	12110STW	130849	30110STW	4	27.0	2.62	1.24	0.67	30AH	14SH
SEDA0616STW	Wabash	762.8	16	20/7	12110STW	130843	30110STW	4	27.0	2.62	1.24	0.67	30AH	14SH
SEDA3307STW	Tern/TW	795.0	7	17/7	12110STW	131030	30110STW	4	27.0	2.62	1.24	0.67	30AH	12SH
SEDA3313STW	Condor/TW	795.0	13	20/7	12110STW	130849	30110STW	4	27.0	2.62	1.24	0.67	30AH	14SH
SEDA3316STW	Drake/TW	795.0	16	20/7	12122STW	130952	30126STW	4	27.0	2.62	1.24	0.67	30AH	16SH
SEDA3323STW	Mallard/TW	795.0	23	22/19	12122STW	130951	30126STW	4	27.6	2.62	1.24	0.67	30AH	16SH
SEDA3813STW	Canary/TW	900.0	13	30/7	12122STW	131240	30126STW	4	27.6	2.62	1.24	0.67	30AH	14SH
SEDA0810STW	Frasier	946.7	10	35/7	12126STW	130848	30126STW	4	27.6	2.62	1.24	0.67	30AH	14SH
SEDA4107STW	Rail/TW	954.0	7	32/7	12126STW	131032	30126STW	4	27.6	2.62	1.24	0.67	30AH	12SH
SEDA4113STW	Cardinal/TW	954.0	13	20/7	12126STW	130952	30126STW	4	27.6	2.62	1.24	0.67	30AH	16SH
SEDA0707STW	Kettle	957.2	7	32/7	12126STW	131033	30126STW	4	27.6	2.62	1.24	0.67	30AH	12SH
SEDA1016STW	Suwanee	959.6	16	22/7	12126STW	130948	30126STW	4	27.6	2.62	1.24	0.67	30AH	16SH
SEDA0913STW	Columbia	966.2	13	21/7	12126STW	130949	30126STW	4	27.6	2.62	1.24	0.67	30AH	16SH
SEDA4407STW	Ortolan/TW	1033.5	7	32/7	12132STW	131632	30132STW	4	29.4	2.62	1.24	0.78	34AH	12SH
SEDA4413STW	Curlew/TW	1033.5	13	22/7	12133STW	131948	30132STW	4	29.6	2.62	1.24	0.78	34AH	16SH
SEDA4707STW	Bluejay/TW	1113.0	7	33/7	12133STW	131634	30132STW	4	29.6	2.62	1.24	0.78	34AH	12SH
SEDA4713STW	Finch/TW	1113.0	13	38/19	12133STW	131949	30132STW	4	29.6	2.62	1.24	0.78	34AH	16SH
SEDA1407STW	Genesee	1158.0	7	33/7	12132STW	130847	30132STW	4	29.4	2.62	1.24	0.67	34AH	14SH
SEDA1513STW	Hudson	1158.4	13	25/7	12133STW	131949	30132STW	4	29.6	2.62	1.24	0.78	34AH	16SH
SEDA4907STW	Bunting/TW	1192.5	7	33/7	12133STW	131541	30132STW	4	29.6	2.62	1.24	0.78	34AH	14SH
SEDA4913STW	Grackle/TW	1192.5	13	38/19	12133STW	131955	30132STW	4	29.6	2.62	1.24	0.78	34AH	16SH
SEDA1913STW	Yukon	1233.6	13	38/19	12145STW	131950	30145STW	4	30.4	2.62	1.24	0.78	36AH	16SH
SEDA1707STW	Nelson	1257.1	7	35/7	12137STW	131540	30136STW	4	30.4	2.62	1.24	0.78	34AH	14SH
SEDA5107STW	Bittern/TW	1272.0	7	35/7	12145STW	131541	30145STW	4	31.2	2.26	1.24	0.78	36AH	14SH
SEDA5113STW	Pheasant/TW	1272.0	13	39/19	12141STW	132250	30141STW	4	31.5	2.62	1.24	0.94	36AH	18SH
SEDA2313STW	Thames	1334.6	13	39/19	12141STW	132250	30141STW	4	31.5	2.62	1.24	0.94	36AH	18SH
SEDA5207STW	Dipper/TW	1351.5	7	35/7	12145STW	131540	30145STW	4	31.2	2.62	1.24	0.78	36AH	14SH
SEDA5213STW	Martin/TW	1351.5	13	39/19	12151STW	132250	30149STW	4	33.4	2.62	1.24	0.94	38AH	18SH

Continued on next page



DEADENDS

COMPRESSION CONVENTIONAL (2-DIE)

ACSS/TW CONDUCTORS (CONTINUED)

TA-31

SINGLE TONGUE ⁽¹⁾ DEADEND ASSEMBLY CATALOG NUMBER	ACSS CONDUCTOR ⁽²⁾				COMPONENT CATALOG NUMBER			# PAD BOLTS	DIMENSIONS (IN.) (L BEFORE COMPRESSION)				DIE SIZE ⁽⁴⁾	
	CODE WORD	KCMIL	TYPE	STRAND AL / STL	ALUMINUM BODY	STEEL EYE	TERMINAL 15° ⁽³⁾		L	A	B	C	ALUM	STEEL
SEDA5407STW	Bobolink/TW	1431.0	7	36/7	12151STW	1323391	30149STW	4	33.4	2.62	1.24	0.94	38AH	14SH
SEDA5413STW	Plover/TW	1431.0	13	39/19	12151STW	132251	30149STW	4	33.4	2.62	1.24	0.94	38AH	18SH
SEDA2713STW	Merrimack	1433.6	13	39/19	12151STW	132251	30149STW	4	33.4	2.62	1.24	0.94	38AH	18SH
SEDA3013STW	Rio Grande	1533.3	13	39/19	12151STW	132252	30149STW	4	33.4	2.62	1.24	0.94	38AH	18SH
SEDA2907STW	Potomac	1557.4	7	36/7	12151STW	132042	30149STW	4	33.4	2.62	1.24	0.94	38AH	16SH
SEDA5707STW	Lapwing/TW	1590.0	7	36/7	12157STW	132042	30157STW	4	33.4	2.62	1.24	0.94	40AH	16SH
SEDA5713STW	Falcon/TW	1590.0	13	42/19	12157STW	132254	30157STW	4	34.2	2.62	1.24	0.94	40AH	18SH
SEDA3107STW	Schukill	1657.4	7	36/7	12157STW	132042	30157STW	4	34.2	2.26	1.24	0.94	40AH	16SH
SEDA6008STW	Chukar/TW	1780.0	8	37/19	12167STW	132248	30167STW	4	35.1	2.62	1.24	0.94	42AH	16SH
SEDA3413STW	Cumberland	1926.9	13	42/19	12168STW	132703	30167STW	4	35.8	3.00	1.50	1.08	42AH	20SH
SEDA3607STW	Athabaska	1949.6	7	42/7	12167STW	132046	30167STW	4	35.1	2.62	1.24	0.94	42AH	16SH
SEDA6308STW	Bluebird/TW	2156.0	8	64/19	12184STW	1327516	30184STW	4	39.0	3.00	1.50	1.08	44AH	18SH

- (1) TO SPECIFY DOUBLE TONGUE DEADEND ASSEMBLY, CHANGE FIRST CHARACTER OF CATALOG NUMBER FROM "S" TO "D". TO SPECIFY DEADEND ASSEMBLY WITHOUT JUMPER TERMINAL, ADD "NT" SUFFIX TO CATALOG NUMBER.
- (2) DEADENDS ARE FULL-TENSION RATED FOR ACSS CONDUCTORS WITH STANDARD, HIGH-STRENGTH (HS) AND (EHS/UHS) STEEL CORES.
- (3) 15 DEGREE JUMPER TERMINAL ALLOWS FOR 0 OR 30 DEGREE JUMPER TAKE-OFF ANGLE FROM 15 DEGREE DEADEND TONGUE. SEPARATELY ORDERED STRAIGHT TERMINALS MAY BE SPECIFIED BY CHANGING TERMINAL COMPONENT CATALOG NO. PREFIX FROM "30" TO "33".
- (4) COMPRESSION PRESS MINIMUM SIZE:
 20AH AND SMALLER - 12 TON 10SH AND SMALLER - 12 TON
 24AH THROUGH 40AH - 60 TON 12SH AND LARGER - 60 TON
 42AH AND LARGER - 100 TON
- (5) TO SPECIFY OPTIONAL STAINLESS STEEL TERMINAL HARDWARE, INCLUDING REQUIRED BELLEVILLE WASHERS, ADD "SS" SUFFIX TO CATALOG NUMBER OF DEADEND ASSEMBLY OR SEPARATELY ORDERED TERMINAL. JOINT COMPOUND: FITTINGS ARE ACSS-RATED WHEN INSTALLED WITH FARGO HTJC-16 JOINT COMPOUND - SEE TABLE BELOW FOR NUMBER OF 16 OZ. TUBES REQUIRED FOR DEADEND BODY AND TERMINAL COMPONENTS.
- (6) DEADENDS ARE EHV RATED WHERE CONDUCTOR IS 1.0 IN. (25.4 MM) O.D. OR LARGER.
- (7) DEADENDS ARE RATED FULL-TENSION ON ACSS CONDUCTORS WITH STEEL CORE STRENGTHS MA5 & LOWER.

FARGO Type HTJC-16 Joint Compound required (cartridges per fitting)											
Component	Die Size										
	20AH	24AH	27AH	30AH	34AH	36AH	38AH	40AH	42AH	44AH	44AH
Deadend Body	0.15	0.24	0.34	0.50	0.56	0.62	0.82	0.90	1.10	1.20	1.20
Jumper Terminal	0.04	0.06	0.07	0.10	0.14	0.16	0.18	0.22	0.25	0.30	0.30



DEADEND ACCESSORIES

CONVENTIONAL TUBE SINGLE DIE ALL ALUMINUM (AAC) CONDUCTORS

TA-32

AAC CONDUCTOR INFORMATION					SEE FOOTNOTE 1 ASSEMBLY NUMBER (SUFFIX)	DEADEND CATALOG NOS.			NOTE 2 15° JUMPER TERMINAL CATALOG NOS.	ALUMINUM COMPRES- SION DIE	MIN. PRESS SIZE (TONS)
KCMIL AVG	STRANDS	CODE WORD	OUTSIDE DIAMETER (IN.)	RATED STRENGTH (LBS.)		AL. SGL. TONGUE	AL. DBL. TONGUE	STEEL EYE			
795.0	37	Arbutus	1.026	13,900	3300	21107	24107	2210	30107	27AH	60
795.0	61	Lilac	1.028	14,300	3300	21107	24107	2210	30107	27AH	60
900.0	37	Cockscomb	1.092	15,400	3800	21117	24117	2210	30117	30AH	60
900.0	61	Snapdragon	1.094	15,900	3800	21117	24117	2210	30117	30AH	60
954.0	37	Magnolia	1.124	16,400	4100	21119	24119	2210	30119	30AH	60
954.0	61	Goldenrod	1.126	16,900	4100	21119	24119	2210	30119	30AH	60
1000.0	37	Hawkweed	1.151	17,200	4200	21119	24119	2210	30119	30AH	60
1000.0	61	Camellia	1.152	17,700	4200	21119	24119	2210	30119	30AH	60
1033.5	37	Bluebell	1.170	17,700	4400	21122	24122	2212	30122	30AH	60
1033.5	61	Larkspur	1.172	18,300	4400	21122	24122	2212	30122	30AH	60
1113.0	61	Marigold	1.216	19,700	4700	21127	24127	2212	30127	34AH	60
1192.5	61	Hawthorn	1.258	21,100	4900	21132	24132	2216	30132	34AH	60
1272.0	61	Narcissus	1.300	22,000	5100	21136	24136	2216	30136	34AH	60
1351.5	61	Columbine	1.340	23,400	5200	21141	24141	2216	30141	36AH	60
1431.0	61	Carnation	1.379	24,300	5400	21145	24145	2216	30145	36AH	60
1510.5	61	Gladiolus	1.417	25,600	5600	21149	24149	2218	30149	38AH	60
1590.0	61	Coreopsis	1.454	27,000	5700	21153	24153	2218	30153	38AH	60
1590.0	91	Dogwood	1.454	27,800	5700	21153	24153	2218	30153	38AH	60
1750.0	61	Jessamine	1.525	29,700	5900	21157	24157	2221	30157	40AH	60
2000.0	91	Cowslip	1.630	34,200	6200	21169	24169	2221	30169	42AH	100
2250.0	91	Sagebrush	1.729	37,700	6500	21178	24178	2221	30178	44AH	100
2300.0	61	Pigweed	1.748	39,000	6600	21181	24181	2225	30181	44AH	100
2500.0	91	Lupine	1.823	41,900	6800	21188	24188	2225	30188	44AH	100

- (1) TO CONSTRUCT ASSEMBLY CATALOG NUMBERS
 STEP 1. CHOOSE ASSEMBLY TYPE FROM FOLLOWING:
 SEDA = SINGLE TONGUE, EYE TYPE, DEADEND ASSEMBLY
 DEDA = DOUBLE TONGUE, EYE TYPE, DEADEND ASSEMBLY
 STEP 2. REFER TO CONDUCTOR LISTING FOR ASSEMBLY NUMBER (SUFFIX)
 EXAMPLE: SEDA-3300 = SINGLE TONGUE, EYE TYPE, DEADEND
 FOR 795 KCMIL 37 STRAND "ARBUTUS"

NOTES: The Deadend assemblies include the steel eyes, aluminum bodies, and jumper terminals (with mounting hardware).
 Suffix "NT" = Assembly without jumper terminal

- (2) 15 DEGREE JUMPER TERMINAL ALLOWS FOR 0 OR 30 DEGREE JUMPER TAKE-OFF ANGLE FROM 15 DEGREE DEADEND TONGUE.
 (3) INSTALL WITH FARGO TYPE UJC JOINT COMPOUND. OR, FOR LOWEST RESISTANCE CONNECTION, INSTALL WITH FARGO TYPE HTJC JOINT COMPOUND.
 (4) FOR AAC CONDUCTORS SMALLER THAN 795 KCMIL, FARGO OFFERS UNI-GRIP® SINGLE-DIE DEADENDS, AS LISTED ON EARLIER PAGES OF THIS CATALOG SECTION
 (5) DEADENDS ARE EHV RATED WHERE CONDUCTOR IS 1.0 IN. (25.4 MM) O.D. OR LARGER.

DEADEND COMPRESSION SINGLE DIE SYSTEM STATIC WIRE DEADEND ALUMOWELD® AND EHS STEEL

FORGED STEEL
86

TA-33

A full tension shield wire deadend assembly for Alumoweld® conductor consists of a grit lined steel body that is capped and sealed. Also available with a two hole tongue or U-bolt pad factory compressed. Two hole tongue has NEMA hole spacing. All tapers and pads are coated with a protective strippable plastic.

Material: Body—Galvanized forged steel
Two Hole Pad—Cast Aluminum
U-bolt & Hardware—Aluminum Alloy

- Notes:** (1) For two hole pad add suffix "S".
Examples: 861225S - Vertical Eye
861225SH - Horizontal Eye
(2) For U-bolt jumper pad add suffix "J".
Examples: 861225J - Vertical Eye
861225JH - Horizontal Eye
(3) Consult factory for other wire sizes.

IDENTIFICATION:
CONDUCTOR SIZE, STRANDING & TYPE
DIE SIZE, MINIMUM PRESS SIZE
FARGO DATE CODE
UNI-GRIP CATALOG NO.

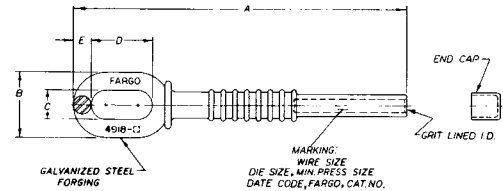
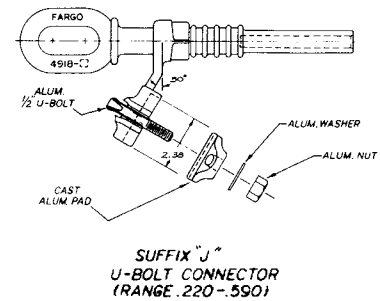
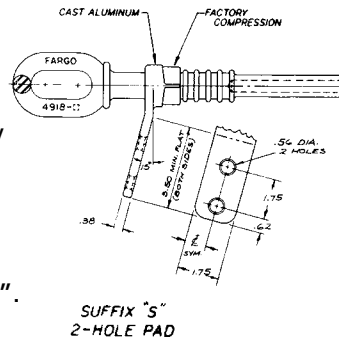

CATALOG NUMBER	SHIELD WIRE DATA			DIE SIZE	MIN. PRESS (TONS)	NET WT. LB (KG)	STEEL EYE DIMENSIONS IN (MM)				
	O.D. (IN.)	EHS STEEL	ALUMOWELD®				A	B	C	D	E
861022	0.306 - 0.313	5/16	7 # 10, 3 # 7	10SH	12	1.5 (.68)	10.6 (270)	1.98 (50)	1.00 (25)	2.5 (60)	.49 (12)
861225	0.343 - 0.375	3/8	7 # 9, 3 # 6	12SH	60	1.5 (.68)	10.6 (270)	1.98 (50)	1.00 (25)	2.5 (60)	.49 (12)
861227	0.385 - 0.392	-	7 # 8, 3 # 5	12SH	60	1.5 (.68)	10.6 (270)	1.98 (50)	1.00 (25)	2.5 (60)	.49 (12)
861430	0.417 - 0.438	7/16	7 # 7	14SH	60	3.0 (1.4)	13.4 (340)	2.58 (60)	1.24 (30)	2.62 (70)	.67 (17)
861635	0.486 - 0.500	1/2	7 # 6	16SH	60	3.0 (1.4)	13.4 (340)	2.58 (60)	1.24 (30)	2.62 (70)	.67 (17)



WEDGE/FORMED WIRE TOWER GUY DEADEND NON-ADJUSTABLE

STEEL
GA/AWA0

TA-34

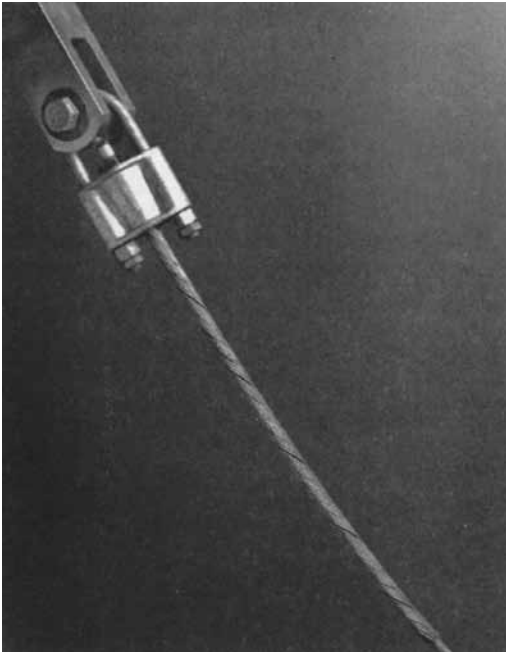

ADJUST-A-GRIP® DEADEND GRIPS FOR STRUCTURE ATTACHMENT OF GUY STRAND

Quick and easy to install. No special tools, eyes pins, thimbles, clevises, twisted-loop grips.

By design, each size is rated to hold more than the rated breaking strength of the guy strand it fits (see tables below).

Proper tensioning: With rod subsets unwrapped, wedge and socket assembly retains a substantial percentage of strand strength rating. For proper deadend performance, guy tension should be at least 5% of strength rating at time of structure erection and at least 10% after final tensioning.

For use on galvanized strand not made per ASTM A475 or aluminum-coated strand not per A474 and/or B416, consult factory. See **dimensions and hardware recommendations on next page.**

These "zero-adjust" Adjust-A-Grip deadend grips are in- stalled at the structure end of guy strands.

for Galvanized-Steel Strands

CATALOG NUMBER	COLOR CODE	STRENGTH RATING	STANDARD PACKAGE	WT. PER 100 PCS.
Strand Size: 1/2" diameter, 7 or 19W		26,900	4	675
12GA0	Blue			
Strand Size: 9/16" diameter, 7 or 19W		35,000	4	675
916GA0	Yellow			
Strand Size: 5/8" diameter, 7 or 19W		42,400	2	413
58GA0	Black			
Strand Size: 3/4" diameter, 19W		58,300	2	588
34GA0	Red			
Strand Size: 7/8" diameter, 19W		79,700	2	1,550
78GA0	Green			
Strand Size: 1" diameter, 19 or 37W		104,500	2	2,300
1GA0	Blue			

Left-Hand Lay Standard

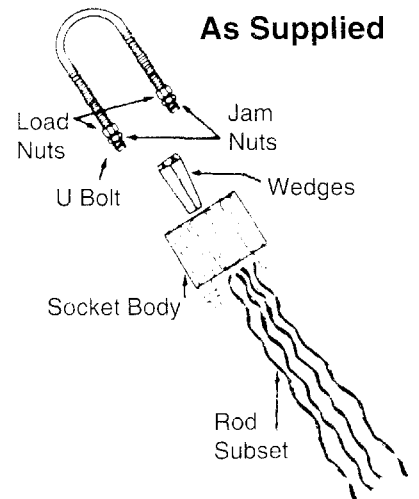



WEDGE/FORMED WIRE TOWER GUY DEADEND NON-ADJUSTABLE (CONTINUED)

TA-35

for Aluminum-coated Strands (Alumoweld®)

CATALOG NUMBER	COLOR CODE	STRENGTH RATING	STANDARD PACKAGE	WT. PER 100 PCS.
Strand Size: .572" dia., 19-No. 9		34,290	4	650
572AWA0	Yellow			
Strand Size: .642" dia., 19-No. 8		43,240	2	413
642AWA0	Black			
Strand Size: .713" dia., 37-No. 10 .721" dia., 19-No. 7		52,950 51,730	2	575
717AWA0	Red			
Strand Size: .801" dia., 37-No. 9 .810" dia., 19 No. 6		66,700 61,700	2	1,500
805AWA0	Green			
Strand Size: .899" dia., 37-No. 8 .910" dia., 19 No. 5		84,200 73,350	2	2,200
905AWA0	Blue			
Strand Size: 1.010" dia., 37-No. 7		100,700	2	2,300
1010AWA0	Orange			
Strand Size: 1.130" dia., 37-No. 6		120,200	2	3,650
1130AWA0	Yellow			
Strand Size: 1.270" dia., 37-No. 5		142,900	12	7,800
1270AWA0	Black			

Left-Hand Lay Standard



WEDGE/FORMED WIRE TOWER GUY DEADEND NON-ADJUSTABLE (CONTINUED)

TA-36

ADJUST-A-GRIP® DEADEND GRIPS
NON-ADJUSTABLE TYPE, FOR STRUCTURE END
OF GUY STRAND

Dimensional Data

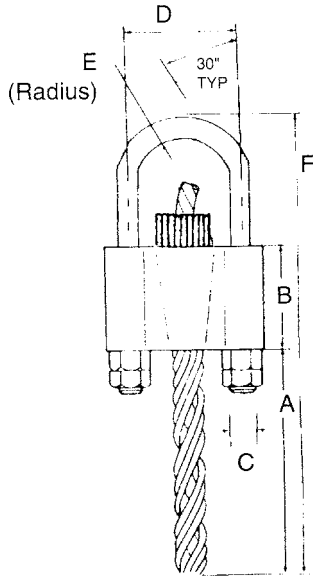

CATALOG NUMBER	DIMENSIONS					
	A	B	C	D	E	F
12GA0	27	3-1/4	5/8	3-1/4	3/4	34
916GA0	28	3-1/4	5/8	3-1/4	3/4	35
58GA0	31-1/2	3-1/2	3/4	3-1/2	1-1/4	39
34GA0	36	4	7/8	4	1-1/4	45
78GA0	36-1/2	4-1/2	1	4-1/2	1-1/2	46
1GA0	45	5	1-1/8	5-3/8	1-1/2	56
572AWA0	27	3-1/4	5/8	3-1/4	3/4	34
642AWA0	28-1/2	3-1/2	3/4	3-1/2	1-1/4	36
717AWA0	33	4	7/8	4	1-1/4	42
805AWA0	36-1/2	4-1/2	1	4-1/2	1-1/2	46
905AWA0	41	5	1-1/8	5-3/8	1-1/2	52
1010AWA0	45	5	1-1/8	5-3/8	1-1/2	56
1130AWA0	48-1/2	5-1/2	1-1/4	5-3/8	2	61
1270AWA0	53-1/2	6-1/2	1-3/8	7-7/8	2	67

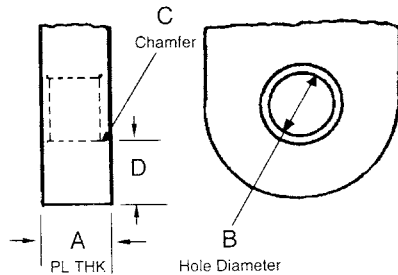

Hardware Recommendations

Recommended distances at left, below, ensure that interference cannot occur between Adjust-A-Grip deadend grip U-bolt and the attachment plate.

If Adjust-A-Grip deadend grips are installed on a pin, as in a shackle, the minimum pin diameters are as follows:

U-BOLT DIAMETER	RECOMMENDED DIMENSIONS INCHES			
	A	B	C	D
5/8	1-1/16	1	1/8 x 45°	1
3/4	1-1/8	1-1/4	1/8 x 45°	1-1/8
7/8	1-3/8	1-1/2	1/8 x 45°	1-1/4
1	1-5/8	1-1/2	3/16 x 45°	1-1/4
1-1/8	1-7/8	1-3/4	1/4 x 45°	1-5/8
1-1/4	2-1/8	1-3/4	1/4 x 45°	1-7/8
1-3/8	2-1/4	2-7/8	5/16 x 45°	2

U-BOLT DIA. INCHES	MINIMUM PIN DIA. INCHES
5/8	7/8
3/4	7/8
7/8	1-1/8
1	1-1/8
1-1/8	1-3/8
1-1/4	1-1/2
1-3/8	1-3/4

For unusual applications or requirements, consult Factory.



WEDGE/FORMED WIRE TOWER GUY DEADEND ADJUSTABLE

STEEL
GA/AWA18

TA-37

ADJUST-A-GRIP® DEADEND GRIPS FOR STRUCTURE ATTACHMENT OF GUY STRAND

Quick and easy to install. No special tools, eyes pins, thimbles. Retensioning up to 18 inches at ground level without removal.

By design, each size is rated to hold more than the rated breaking strength of the guy strand it fits (see tables below).

Vandal resistant: With rod subsets unwrapped, wedge and socket assembly retains a substantial percentage of strand strength rating. For proper deadend performance, guy tension should be at least 5% of strength rating at time of structure erection and at least 10% after final tensioning.

For use on galvanized strand not made per ASTM A475 or aluminum-coated strand not per A474 and/or B416, consult Factory. See dimensions and hardware recommendations on next page.

†Serving sleeves are required on adjustable Adjust-A-Grip deadend grips when used on structures of 200 ft. and taller.



for Galvanized-Steel Strands

†CATALOG NUMBER	U-BOLT ADJUSTMENT	COLOR CODE	STRENGTH RATING, LB.	STANDARD PACKAGE	WT. PER 100 LB.
Strand Size: 1/2" diameter, 7 or 19W			26,900	4	1,000
12GA18	18"	Blue			
Strand Size: 9/16" diameter, 7 or 19W			35,000	4	1,025
916GA18	18"	Yellow			
Strand Size: 5/8" diameter, 7 or 19W			42,400	2	663
58GA18	18"	Black			
Strand Size: 3/4" diameter, 19W			58,300	2	938
34GA18	18"	Red			
Strand Size: 7/8" diameter, 19W			79,700	2	2,450
78GA18	18"	Green			
Strand Size: 1" diameter, 19 or 37W			104,500	2	3,450
1GA18	18"	Blue			

Left-Hand Lay Standard

†To order the above Adjust-A-Grips with serving sleeve included, add the suffix "S" to the catalog number (i.e.: 12GA18S).

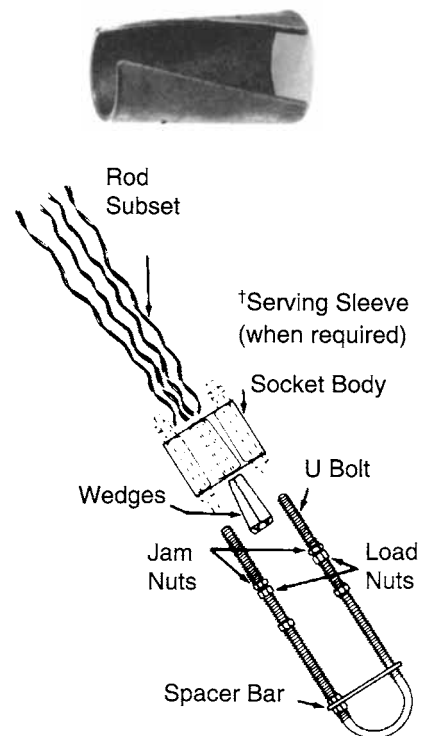



WEDGE/FORMED WIRE TOWER GUY DEADEND ADJUSTABLE (CONTINUED)

TA-38

for Aluminum-Coated Strands

†CATALOG NUMBER	U-BOLT ADJUSTMENT	COLOR CODE	STRENGTH RATING, LB.	STANDARD PACKAGE	WT. PER 100 LB.
Strand Size: .572" dia., 19-No. 9			34,290	4	1,000
572AWA18	18"	Yellow			
Strand Size: .642" dia., 19-No.8			43,240	2	663
642AWA18	18"	Black			
Strand Size: .713" dia., 37-No. 10 .721" dia., 19-No. 7			52,950 51,730	2	925
717AWA18	18"	Red			
Strand Size: .801" dia., 37-No. 9 .810" dia., 19 No. 6			66,770 61,700	2	2,400
805AWA18	18"	Green			
Strand Size: .899" dia., 37-No. 8 .910" dia., 19 No. 5			84,200 73,350	2	3,400
905AWA18	18"	Blue			
Strand Size: 1.010" dia., 37-No. 7			100,700	2	3,500
1010AWA018	18"	Orange			
Strand Size: 1.130" dia., 37-No. 6			120,200	2	4,950
1130AWA18	18"	Yellow			
Strand Size: 1.270" dia., 37-No. 5			142,900	12	10,000
1270AWA18	18"	Black			

Left-Hand Lay Standard

†To order the above Adjust-A-Grips with serving sleeve included, add the suffix "S" to the catalog number (i.e.: 572AWA18S).

WEDGE/FORMED WIRE TOWER GUY DEADEND (CONTINUED)

ADJUST-A-GRIP® DEADEND GRIPS ADJUSTABLE TYPE, FOR ANCHOR END OF GUY STRAND

Dimensional Data

CATALOG NUMBER	DIMENSIONS						SERVING SLEEVE CATALOG NUMBER
	A	B	C	D	E	F	
12GA18	27	3-1/4	5/8	3-1/4	3/4	51	GA1
916GA18	28	3-1/4	5/8	3-1/4	3/4	52	GA1
58GA18	31-1/2	3-1/2	3/4	3-1/2	1-1/4	56	GA2
34GA18	36	4	7/8	4	1-1/4	62	GA2
78GA18	36-1/2	4-1/2	1	4-1/2	1-1/2	63	GA3
1GA18	45	5	1-1/8	5-3/8	1-1/2	73	GA4
572AWA18	27	3-1/4	5/8	3-1/4	3/4	51	GA1
642AWA18	28-1/2	3-1/2	3/4	3-1/2	1-1/4	53	GA2
717AWA18	33	4	7/8	4	1-1/4	59	GA3
805AWA18	36-1/2	4-1/2	1	4-1/2	1-1/2	63	GA3
905AWA18	41	5	1-1/8	5-3/8	1-1/2	69	GA4
1010AWA18	45	5	1-1/8	5-3/8	1-1/2	73	GA4
1130AWA18	48-1/2	5-1/2	1-1/4	5-3/8	2	78	GA5
1270AWA18	53-1/2	6-1/2	1-3/8	7-7/8	2	84	GA5

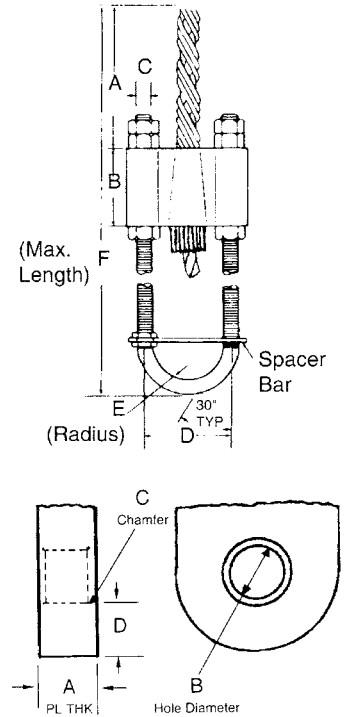

Hardware Recommendations

Recommended distances at left, below, ensure that interference cannot occur between Adjust-A-Grip deadend grip U-bolt and the attachment plate.

If Adjust-A-Grip deadend grips are installed on a pin, as in a shackle, the minimum pin diameters are as follows:

U-BOLT DIAMETER	RECOMMENDED DIMENSIONS INCHES			
	A	B	C	D
5/8	1-1/16	1	1/8 x 45°	1
3/4	1-1/8	1-1/4	1/8 x 45°	1-1/8
7/8	1-3/8	1-1/2	1/8 x 45°	1-1/4
1	1-5/8	1-1/2	3/16 x 45°	1-1/4
1-1/8	1-7/8	1-3/4	1/4 x 45°	1-5/8
1-1/4	2-1/8	1-3/4	1/4 x 45°	1-7/8
1-3/8	2-1/4	2-7/8	5/16 x 45°	2

U-BOLT DIA. INCHES	MINIMUM PIN DIA. INCHES
5/8	7/8
3/4	7/8
7/8	1-1/8
1	1-1/8
1-1/8	1-3/8
1-1/4	1-1/2
1-3/8	1-3/4



WEDGE/FORMED WIRE TOWER GUY DEADEND (CONTINUED)

TA-40 **ADJUST-A-GRIP® DEADENDS
FOR STRUCTURE ATTACHMENT OF GUY STRAND**

Measuring Guy Tension To Load-Nut Torque

Guy tensions may be closely approximated by measuring the torque on the U-Bolt load nuts. For accurate results, the U-Bolt thread and nut must be lubricated with an anti-seize compound, (a commercially available one is called, "Never-Seez").

To use these charts, go first to the correct bolt size chart then select the desired tension on the vertical scale and move across the chart to the intersect line, read the torque required from the horizontal scale.

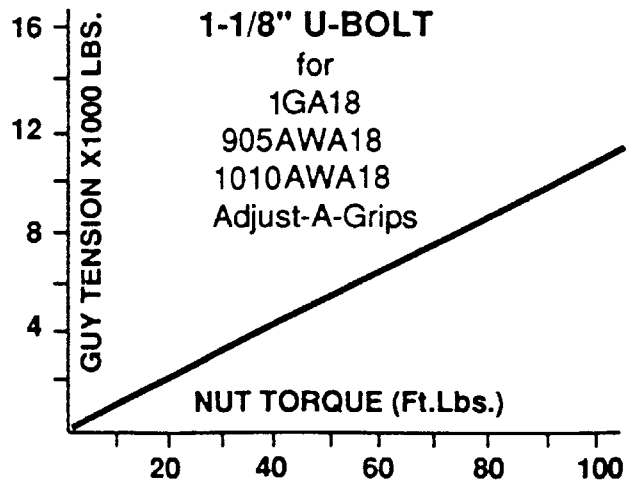
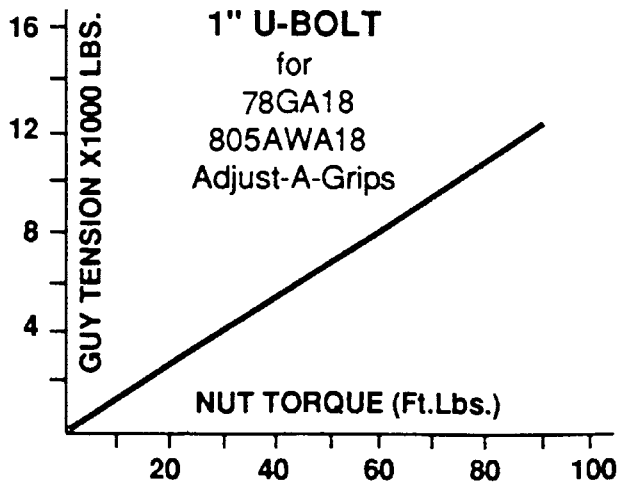
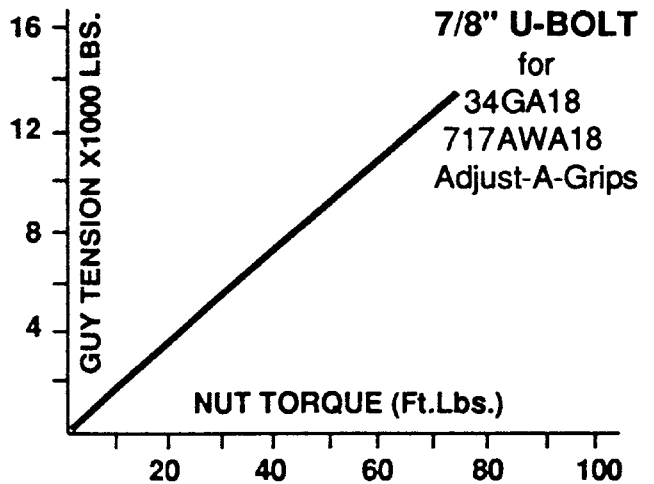
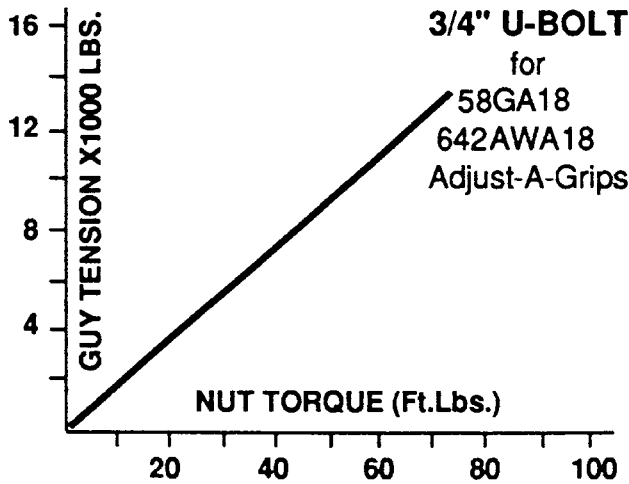
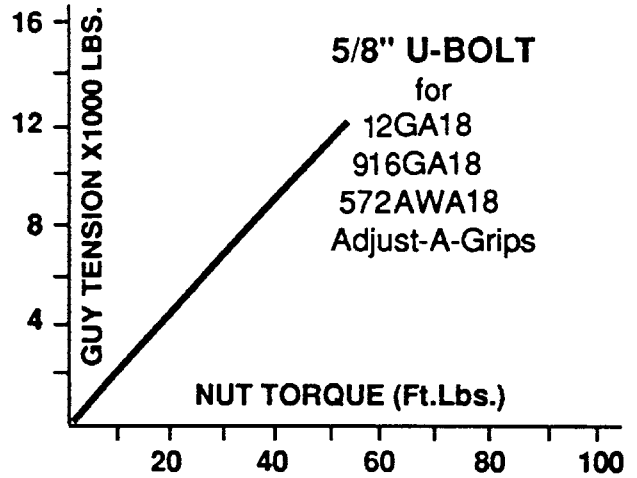

WEDGE/FORMED WIRE TOWER GUY DEADEND (CONTINUED)

ADJUST-A-GRIP® DEADENDS
FOR STRUCTURE ATTACHMENT OF GUY STRAND

TA-41

