

3

Programming ACTUAL TIME

START

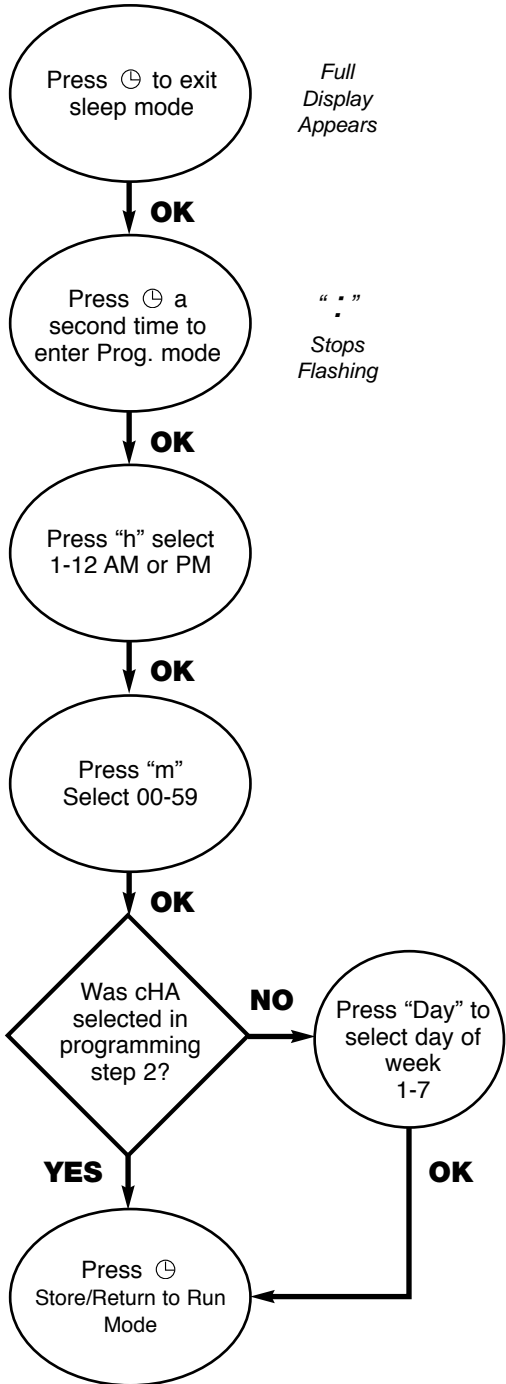

END

4

Programming 24 Hour / 7 Day "ON/OFF" SCHEDULES

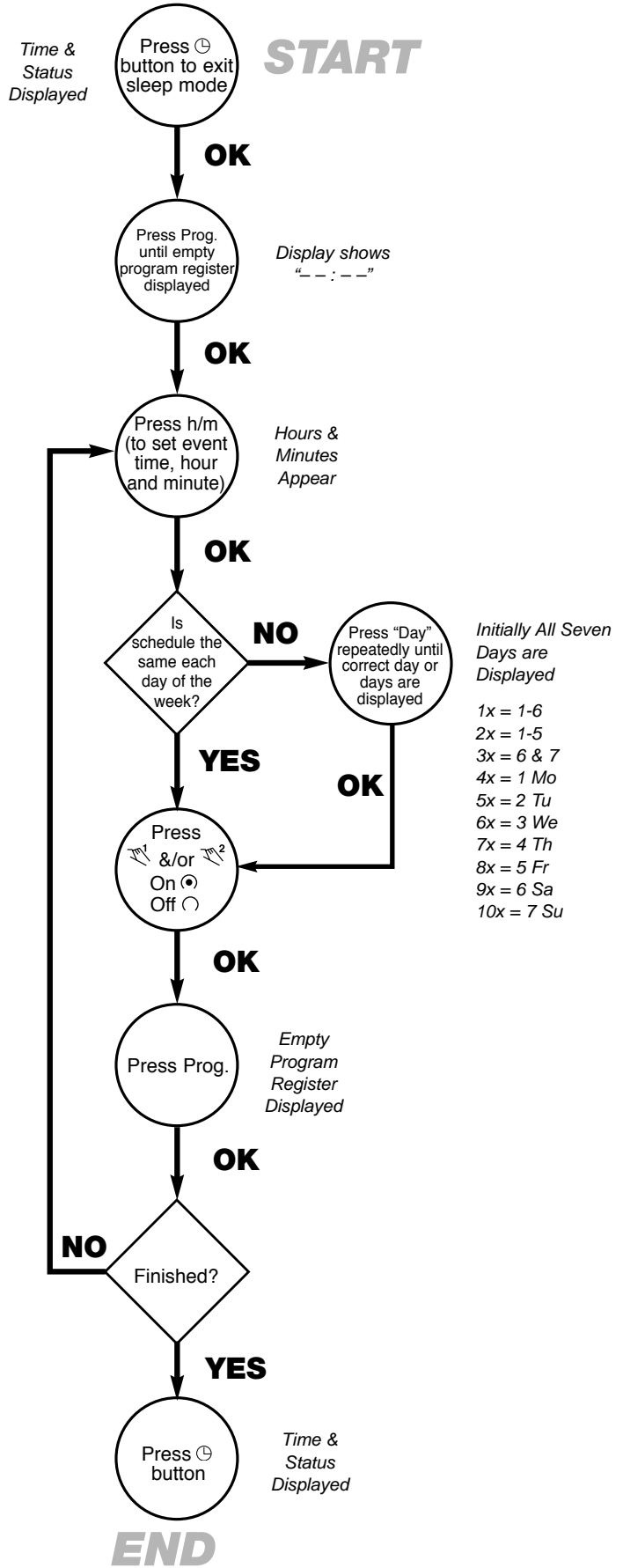

END

Operating Instructions

LightMaster

PC and PC Digi Series

The PC and PC Digi series are one or two channel electronic lighting controls. They are provided with a waterproof light level sensor that can be remotely mounted up to 330 feet away. For Large installations, up to 10 units (20 channels) can be connected to a single sensor. The integral light sensitivity adjustment provides a wide range of settings, making these units applicable for control of indoor and outdoor lighting as well as automatic awnings or shades.

Functional Description

The PC1 and PC2 operate strictly via a light level adjustment. The PC2 unit has an independent light level setting for each channel. Either unit can be connected in series with any Grasslin Time Switch to provide time-of-day control. The two PC “Digi” models incorporate an integral one or two channel electronic timer.

Please read these operating instructions carefully so that you will be able to take full advantage of the functions offered by the PC or PC Digi Series controls.

TO THE INSTALLER:

1. Read the operating instructions carefully.
2. Check the ratings marked on the unit to make sure this product is suitable for your power supply and application.
3. Disconnect power supply prior to installation to prevent electrical shock.
4. Damage to the relay contacts caused by short circuiting will void warranty.
5. Wire in accordance with National and Local electrical code requirements.



In Optional Enclosure

TECHNICAL DATA:

Input Voltage:	Separate models available for 120V, 240V or 277VAC; 50/60 Hz
Relay Switch Rating:	16A @ 250VAC, Res. 12A @ 120VAC, 8A @ 277VAC, Bal.
Output Relay:	SPDT dry contacts for each Channel
Power Consumption:	2.5VA
Battery Backup:	3 years (“digi” units)
Temperature Range:	
Control Unit	-4°F to 131°F (-20°C to 55°C)
Sensor	-22°F to 158°F (-30°C to 70°C)
Humidity Range:	
Control Unit	0 to 95% RH non-condensing
Sensor	0 to 100% RH
Weight:	8.5 oz.
Mounting:	Surface & DIN rail (NEMA 1 & 3R enclosures available)
Light Sensitivity Adj.:	.2 to 50 Foot Candles (2 to 500 F.C. w/ optional sensor)
Time Delay Before Switching	Adjustable, 0 to 100 sec.
Time Switch Accuracy:	± 2.5 seconds per day @ 68°F (20°C)

Installation

MOUNTING

Surface mounting the PC units inside a control panel or enclosure is accomplished with a standard DIN rail.

Place the top two protruding guides, which are on the rear of

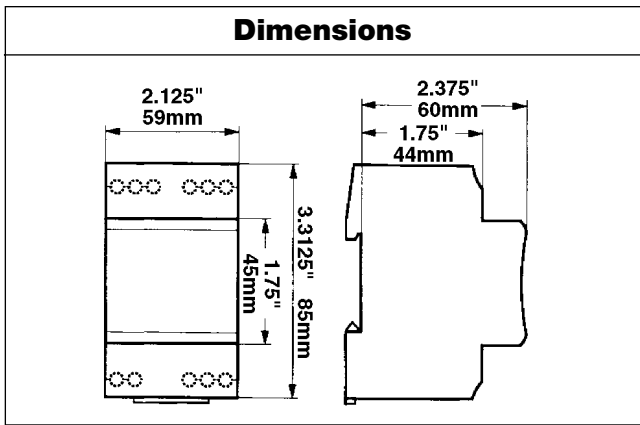

the unit, over the top lip of the DIN rail, then snap the bottom into place.

For stand alone installation use a Grasslin indoor or outdoor enclosure.

INSTALLATION CHECKLIST

1. The control should have its own independent circuit for power supply.
2. Since all electronic instruments are sensitive to voltage spikes, close attention must be paid to the following:
 - a. If possible, power to the unit should be supplied from a phase different from the load
 - b. **INDUCTIVE-LOADS** should have a suitable VARISTOR and RC network ($\sim\sim\sim\sim\sim$) across the supply terminals to reduce voltage spikes.
 - c. **DC INDUCTIVE LOADS** should have a diode across their terminals to eliminate back EMF of the inductor.
 - d. **HIGHLY INDUCTIVE LOADS**, especially fluorescent lights, may require a relay in which case (a) and (c) apply.
 - e. **IN HIGH LIGHTNING AREAS**, a surge suppressor should be installed.

APPLICATION NOTES

The light level sensor is typically located on an outside wall. It must be mounted vertically with the wires facing down. Wiring should not exceed 330 feet in length and should not be run in close proximity to current carrying wires. The sensor wires are at the same potential, with respect to ground, as the control input (120, 240 or 277 volts), but have current flow of less than 0.5 milliamps.

If used for dusk and/or dawn sensing, position the sensor with the arrow facing the wall. When used to control interior lighting, awnings or shades, face the arrow away from the building towards the sunlight. In any application, the sensor must not be influenced by the lights being controlled, auto headlights, etc.

WIRING

Make certain to connect only to the supply voltage designated on the unit itself. Warranty will be void if the wrong voltage is applied. Connect wires to the screw terminals in accordance

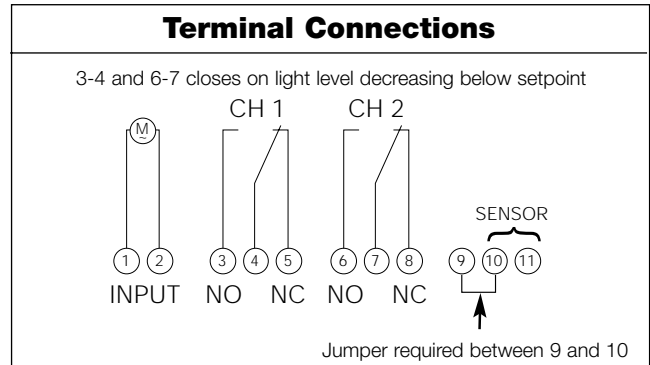

with the wiring diagram shown (use 12 to 22 AWG wire).

1. Wire power to terminals 1 & 2.
2. Wire power into the common of the switch.
3. Wire from the normally open contact(s) of the switch to the load(s) or contactor coil(s) to be controlled.
4. Mount the sensor to a junction box within 330 feet of the control.
5. Connect sensor wire to terminals 10 & 11. Jumper terminal 9 to 10. If multiple PC2's are connected to a single sensor, jumper terminal 9 to 10 on the last unit only.

SENSITIVITY ADJUSTMENT

1. The control is pre-set at 2.75 F.C. (arrow at 11 o'clock), which is the approximate setting for dusk. Fine-tuning may be made at twilight if necessary.
2. For daylight control (settings above 50 F.C.), it is necessary to order the optional "High Range" sensor.

STATUS INDICATION

A red LED is on when the ambient light level is lower than set point. The LCD on "digi" units indicates the status of the time switch.

OPERATING MODES

On "digi", units the following operating modes are available: Automatic (output "on" or "off" depending on time switch schedule and light level), Fixed On or Fixed Off. "On" only functions when red LED is on.

Wiring Multiple PC2s to One Sensor

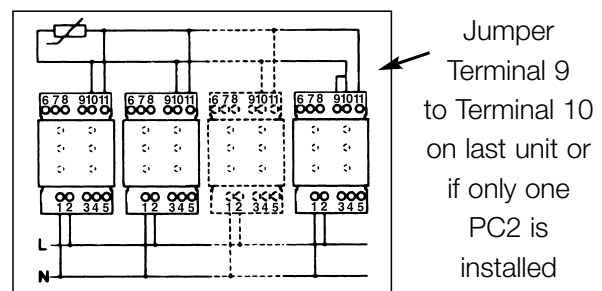

Complete Steps 1-3 Before Programming Timer

1

Programming TIME FORMAT START

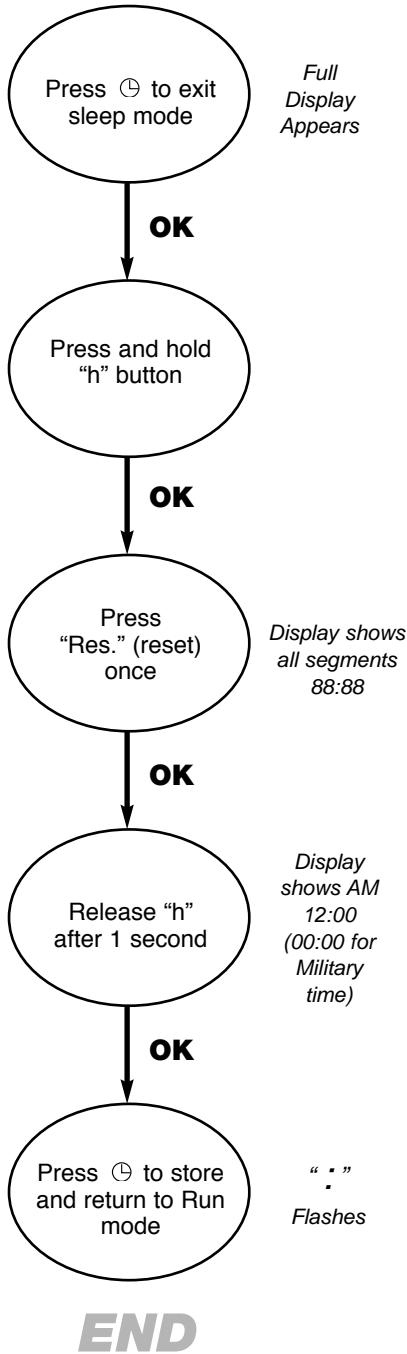

Note: Performing the above operation a second time will switch clock to Military time.

2

Programming DAYLIGHT SAVINGS CHANGEOVER

START

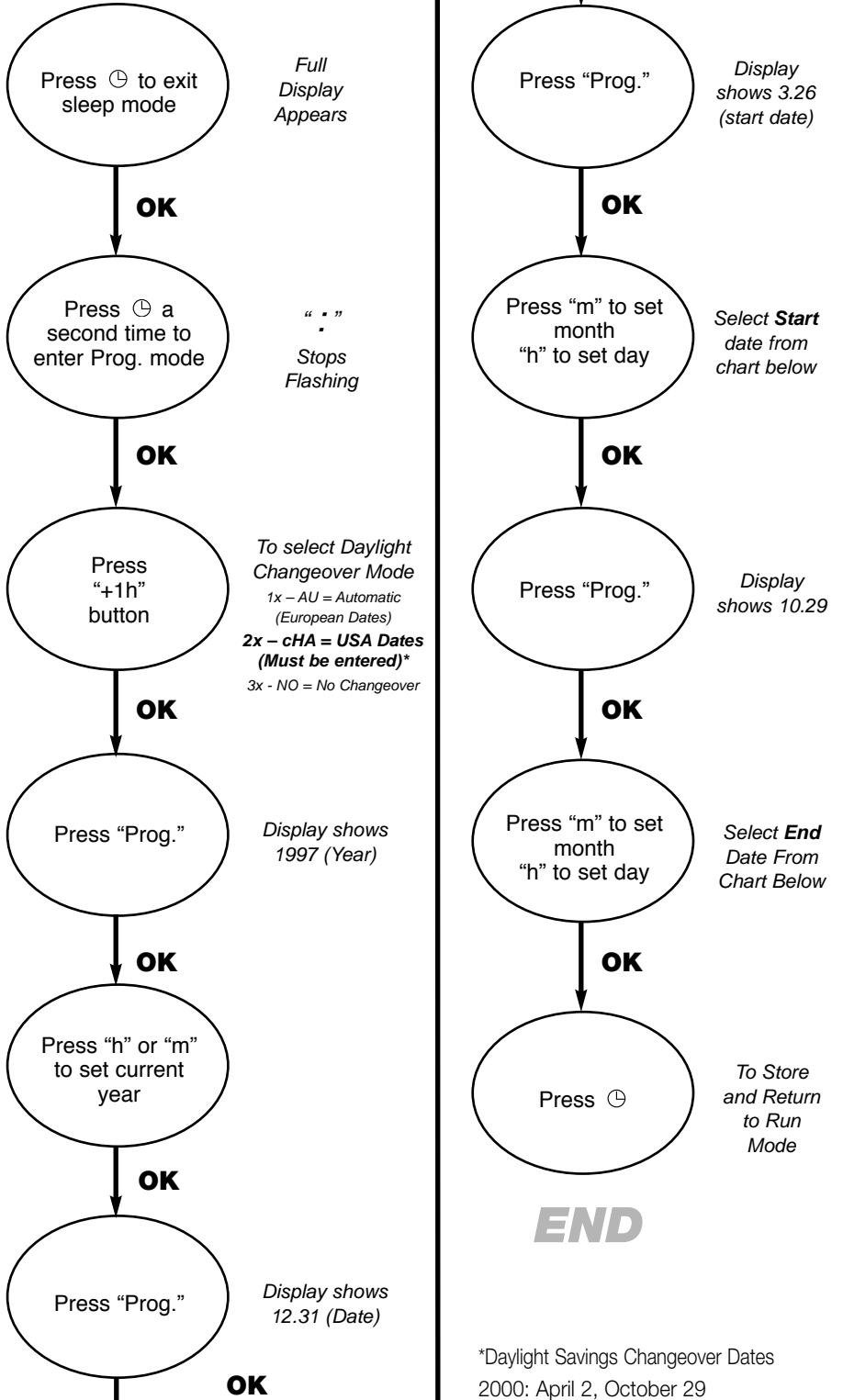

*Daylight Savings Changeover Dates
 2000: April 2, October 29
 2001: April 1, October 28