

Homeowner – Instructions for use

FP Time Controls

Manual Switches
Separate manually operated switches are provided for both the heating and DHW services. A third switch provides a selection between "constant" and "timed" for both services. The following programmes can be selected.

Programme Required.	Htg switch position	DHW switch position	timed/constant switch position
Heating & hot water timed	on	on	Timed
Heating & hot water constant	on	on	Constant
Hot water timed, Htg off	off	on	Timed
Hot water constant, Htg off	off	on	Constant
Heating timed, hot water off	on	off	Timed
Heating constant, hot water off	on	off	Constant
Both services off	off	off	Timed

Programme Advance
Time clock may be advanced to next switching position by rotating programme advance anticlockwise. Red/blue indicator shows **Red** if time switch is **ON**, **blue** if time switch off. i.e. if time control is OFF (blue indicator shows) rotate knob anticlockwise to ON (red indicator shows).

Tower Flue Components Limited
Vale Rise, Tonbridge, TN9 1 TB Kent

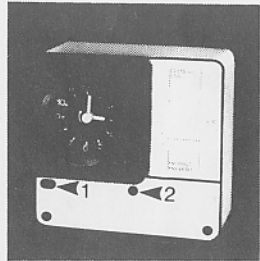

Fig 1

Fixing holes 1 & 2 for surface mounting

Setting Correct Time and required On-Off periods — refer fig 2.

Remove black clock cover by gently pulling outwards. Using centre clock adjuster, turn clock fingers **clockwise** to correct time of day. The Towerchron clock is mechanically linked to a 24 hour outer dial which must also read the correct time of day. Check that Δ pointer is opposite the correct hour of day on the 24 hour dial. (In case of difficulty a "time of day"/24 hour time chart is shown below.)

If not continue rotating centre clock adjuster **clockwise** until correct time of day is reached again. Clock is now set. See example below:

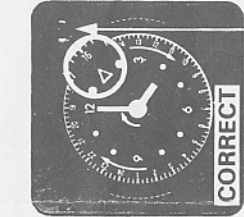

Example - time of day 4 p.m. Time Pointer 24 hour dial Programme Advance Knob

Setting On-Off periods —

- Decide on the time of 'On' periods required.
- Position tappets in outer dial as shown. **Red** tappets switch **On**, **blue** tappets switch **Off**. For example, if you want to switch on between 7 and 10 am and then between 4pm (16.00 on 24 hour dial) and 11pm (23 on dial), tappets are positioned as shown in fig 2.
- In the event of power cuts etc, remember to reset the clock by turning clock fingers **clockwise** only using clock adjuster knob. Fig 3. illustrates tappets being inserted into outer dial — short leg of tappet faces middle of clock.

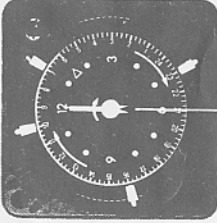

fig 2 Clock Adjuster

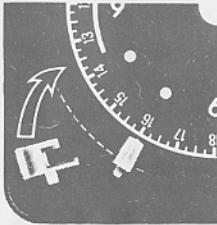

Fig 3



Towerchron Model FP Programmer Installation Sheet

Applications

- Fully pumped central heating systems using mid position valves, spring return valves or "power open" "power closed" valves.
- Gravity primary pumped heating systems where motorised valve is fitted into DHW primary circuit.

Specification

Rating: 250v AC 6 amps resistive load.
Fitting: Surface mounted

Dimensions: Approximately 4.2" (106mm) high x 4.4" (113mm) wide x 2.6" (65mm) deep.
Max. ambient temp. 50°C.

Internal Wiring Diagram

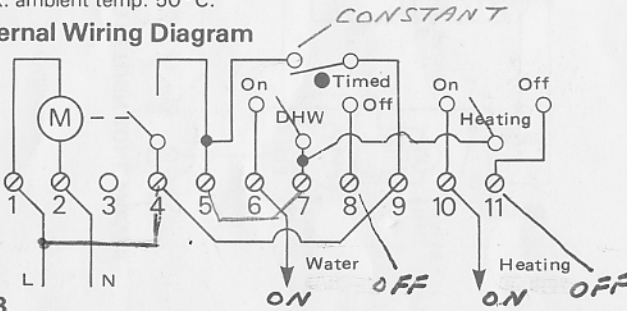

N.B.

- For mains voltage applications place links between 1 & 4. Links must be suitable for full load current.
- Installation must be carried out by a qualified electrician and conform to current I.E.E. regulations.
- Mains supply must be suitably fused (usually 3A) and provision made for class A circuit disconnection
- Control is suitable for fixed wiring only.

Installation

- Loosen fixing screw at bottom of unit and remove terminal cover.
- For surface fixing screw unit to wall with countersunk No. 8 woodscrews using fixing holes 1 & 2 (see fig 1).
- When surface mounted, a cable knockout is provided on the bottom edge of the terminal cover.
- Carry out wiring installation using appropriate diagram as shown. For wiring systems not covered by this sheet refer to Tower Flue Components Ltd.
- Replace terminal cover and secure cover fixing screw.

Setting Correct Time and required On-Off periods — refer fig 2.

Remove black clock cover by gently pulling outwards. Using centre clock adjuster, turn clock fingers **clockwise** to correct time of day. The Towerchron clock is mechanically linked to a 24 hour outer dial which must also read the correct time of day. Check that Δ pointer is opposite the correct hour of day on the 24 hour dial.

If not continue rotating centre clock adjuster **clockwise** until correct time of day is reached again. Clock is now set. See example below:

Example - time of day 4 p.m.

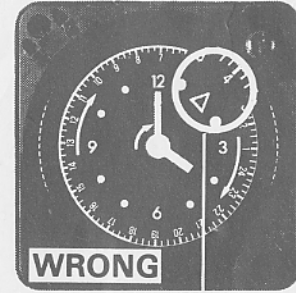

Time Pointer 24 hour dial

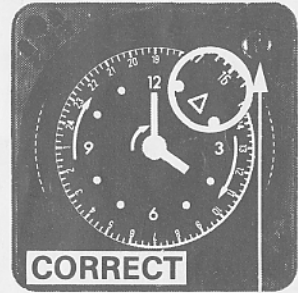

Programme Advance Knob

Setting On-Off periods —

- Decide on the time of 'On' periods required.
- Position tappets in outer dial as shown. **Red** tappets switch **On**, **blue** tappets switch **Off**. For example, if you want to switch on between 7 and 10 am and then between 4pm (16.00 on 24 hour dial) and 11pm (23 on dial), tappets are positioned as shown in fig 2. In the event of power cuts etc, remember to reset the clock by turning clock fingers **clockwise** only using clock adjuster knob.
- Fig 3. illustrates tappets being inserted into outer dial — short leg of tappet faces middle of clock.

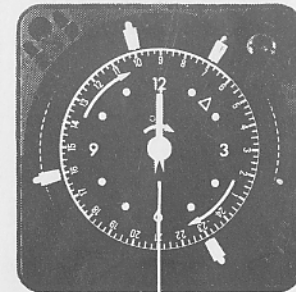

Fig 2 Clock Adjuster

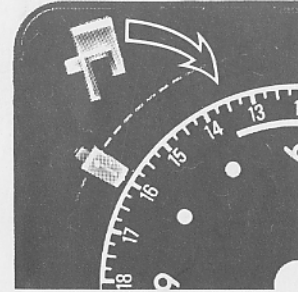

Fig 3

Tower - above the rest
Tower Flue Components Limited
Vale Rise, Tonbridge, TN9 1 TB Kent